

ARMY
NAVY NAVELEX
AIR FORCE

TM 11-7440-222-40P
0967-LP-324-0480
TO 31 W4-2G-84

GENERAL SUPPORT MAINTENANCE REPAIR
PARTS AND SPECIAL TOOLS LIST
(INCLUDING DEPOT MAINTENANCE REPAIR
PARTS AND SPECIAL TOOLS)
FOR

PAPER TAPE PUNCH, LOW SPEED
RO-31 5/G
(NSN 7025-00-997-6209)

DEPARTMENTS OF THE ARMY, THE NAVY, AND THE AIR FORCE
MAY 1979

CHANGE

No. 1

DEPARTMENTS OF THE ARMY,
THE NAVY, AND THE AIR FORCE
Washington, DC, 16 November 1981

**General Support Maintenance Repair
Parts and Special Tools List
(Including Depot Maintenance Repair Parts and Special Tools)
For
PAPER TAPE PUNCH, LOW SPEED RO-315/G
(NSN 7025-00-997-6209)**

TM 11-7440-222-40P/NAVELEX 0967-LP-324-0480/TO 31W4-2G-84, 7 May 1979, is changed as follows:

1. New or changed material is indicated by a vertical bar.
2. Added or revised illustrations are indicated by a vertical bar before figure number and title.
3. Remove and insert pages as indicated.

<i>Remove</i>	<i>Insert</i>
i and ii	i and ii
1 And 2	1 and 2
109 through 112	109 through 112
263 through 272	263 through 272
277 through 280	277 through 280
283 through 288	283 through 288
291/(292 blank)	291 and 292

4. File this change sheet in front of the publication for reference purposes.

By Order of the Secretaries of the Army, the Navy, and the Air Force:

Official:

ROBERT M. JOYCE
Brigadier General, United States Army
The Adjutant General

E. C. MEYER
General, United States Army-
Chief of Staff

Official:

BRYCE POE II
General, USAF, Commander, Air Force
Logistics Command

H. D. ARNOLD
Rear Admiral, United States Navy
Commander, Naval Electronic
Systems Command

LEW ALLEN, JR., *General USAF*
Chief of Staff

Distribution:

To be distributed in accordance with Special List.

TECHNICAL MANUAL
 No. 11-7440-222-40P
 TECHNICAL MANUAL
 NAVELEX 0967-LP-324-0480
 TECHNICAL ORDER
 TO 31W4-2G-84

DEPARTMENTS OF THE ARMY,

 THE NAVY, AND THE AIR FORCE

WASHINGTON, DC, 7 May 1979

**GENERAL SUPPORT MAINTENANCE REPAIR
 PARTS AND SPECIAL TOOLS LISTS
 (INCLUDING DEPOT MAINTENANCE REPAIR
 PARTS AND SPECIAL TOOLS
 FOR
 PAPER TAPE PUNCH, LOW SPEED
 RO-31 5/G
 (NSN 7025-00-997-6209)
 Current as of 18 October 1978**

REPORTING ERRORS AND RECOMMENDING IMPROVEMENTS

You can help improve this manual. If you find any mistakes or if you know of a way to improve the procedures, please let us know. Mail your letter, DA Form 2028 (Recommended Changes to Publications and Blank Forms), or DA Form 2028-2 located in back of this manual direct to Commander, US Army Communications-Electronics Command, ATTN: DRSEL-ME-MQ, Fort Monmouth, NJ 07703.

For Air Force, submit AFTO Form 22 (Technical Order System Publication Improvement Report and Reply) in accordance with paragraph 6-5, Section VI, T.O. 00-5-1. Forward direct to prime ALC/MST.

For Navy, mail comments to the Commander, Naval Electronics Systems Command, ATIN: ELEX 45053 (O.H.), Washington, DC 20360.

In either case, a reply will be furnished direct to you.

Table of Contents

SECTION		Page	Illus Figure
	I. Introduction.....	1	
	II. Repair parts list	5	
Group	00 Paper Tape Punch, Low Speed RO-315/G	5	1
	01 Logic Assembly (A1)	9	2
	0101 Circuit card assembly (A1A14)	11	3
	0102 01 Logic Assembly (A1A13).....	13	2
	0103 Circuit card assembly (A1A12).....	15	5
	0104 Circuit card assembly (A1A16)	17	6
	0105 Circuit card assembly (A1A18) (Same as group 0104)		
	0106 Circuit card assembly (A1A15).....	19	7
	0107 Circuit card assembly (A1A17) (Same as group 0106)		

***This manual supersedes so much of TM 11-7440-222-15/NAVSHIPS 0967-324-0070/TO 31W4-2G-81, 28 March 1969, including all changes, as pertains to repair parts and special tools lists.**

	Page	Illus Figure
0108 Circuit card assembly (A1A1)	25	8
0109 Circuit card assembly (A1A2) (Same as group 0108)		
0110 Circuit card assembly (A1A5)	29	9
0111 Circuit card assembly (A1A6)	31	10
0112 Circuit card assembly (A1A7)	33	11
0113 Circuit card assembly (A1A19)	35	12
0114 Circuit card assembly (A1A9).....	37	13
0115 Circuit card assembly (A1A10).....	39	14
0116 Circuit card assembly (A1A11).....	41	15
0117 Circuit card assembly (A1A4).....	43	16
0118 Circuit card assembly (A1A3)	45	17
0119 Circuit card assembly (A1A20).....	47	18
0120 Logic chassis	49	19
0120()1 Logic assembly (A64504-003).....	51	20
012002 Logic assembly (A64504-004).....	53	21
012003 Front panel assembly.....	55	22
02 Control panel (A2)	57	23
0201 Wiring harness (A65411-001)	58	23
03 Enclosure	61	24
04 Punch assembly (A4).....	63	25
0401 Driver assembly. Punch	65	26
040101 Shelf assembly	67	27
0401010 Wiring harness (A65407-001)	71	28
040102 Circuit card assembly (A4A1)	73	29
040103 Circuit card assembly (A4A2) (Same as group 040102)		
040104 Circuit card assembly (A4A3) (Same as group 040102)		
0402 Perforator assembly	77	30
040201 Motor	83	31
040202 Mechanism, capstan drive	83	31
040203 Mechanism, punch.....	87	32
04020301 Bank clutch, lower left	93	33
0402030101 Clutch and sleeve assembly	91	33
04020302 Bank clutch, upper left	91	34
0402030201 Clutch and sleeve assembly (Same as group 0402030101)		
04020303 Bank clutch, lower right	95	35
0402030301 Clutch and sleeve assembly.	95	35
04020304 Bank clutch, upper right.....	97	36
0402030401 Clutch and sleeve assembly (Same as group 0402030301)		
04020305 Cable assembly, mechanism	99	37
04020306 Head, punch assembly.....	101	38
04020307 Deck, tape (No parts authorized)		
040204 Sensor assembly, tape motion.	103	39
040205 Circuit card assembly (890050).....	105	40
040206 Network resistance-capacitance assembly	107	41
04020601 Circuit card assembly (833070)	109	42
040207 Tape Supply Slide Assembly	111	43
040208 Sensing assembly.	113	44
05 Tape reeler (B2)	115	45
0501 Component assembly	119	46
050101 Circuit card assembly (890202).....	119	46
06 Power supply (PSI).	121	47
0601 Circuit card assembly (PS1A1)	125	48
0602 Circuit card assembly (PS1A2)	127	49
0603 Circuit card assembly (PS1A3)	129	50
0604 Heat sink assembly (PS1A1).....	131	51

Table of Contents-Continued

Group		Page	Ilus Figure
	060401 Heat sink subassembly (PS1A4).....	133	52
	060402 Heat sink assembly (PS1A5)	135	53
	060403 Heat sink assembly (PS1A6)	137	54
	0605 Circuit card assembly (PSA1A2)	141	55
	0606 Connector bracket assembly (PSIA14)	145	56
	060601 Circuit card assembly (A1A15)	145	56
	0607 Front panel assembly (PS1A10)	147	57
07	Plate, interface	149	58
	0701 Wiring harness (A65405-001)	149	58
08	Filter assembly	153	59
09	Blower (B1)	155	60
10	Voltage regulator assembly (VR1)	157	61
	1001 Circuit breaker assembly	157	61
	1002 Printed circuit board assembly (W-7712-27)	159	62
	1003 Heat sink assembly (W-7712-26)	163	63
11	Power supply assembly (PS2)	165	64
	1101 Power supply (PS2)	169	65
	110101 Circuit card assembly (00-001660-002)	173	66
	110102 Circuit card assembly (12-890141-002)	175	67
	110103 Circuit card assembly (12-890142-002)	177	68
	110104 Circuit card assembly (12-890140-002)	179	69
	110105 Circuit card assembly (12-890143-001)	181	70
12	Printer interpreter assembly (A3)	183	71
	1201 Low speed printer interpreter assembly	185	72
	120101 Panel assembly (A3A1)	187	73
	12010101 Ribbon, print wheel assembly (A3A1A2)	193	74
	1201010101 Bracket assembly, phase adjusting	197	75
	12010102 Tape reader assembly	199	76
	1201010201 Switch subassembly	201	77
	1201010202 Tape adjust subassembly	203	78
	12010103 Clamp subassembly	205	79
	12010104 Motor assembly	207	80
	12010105 Tape drive assembly	209	81
	1201010501 Spider assembly, differential	211	82
	1201010502 Magnetic actuator assembly, reverse (L2)	211	82
	1201010503 Magnetic actuator assembly, forward (L1) (No parts authorized)		
	12010106 Cable assembly(40639G1)	213	83
	120102 Circuit card assembly (A3A2A0)	215	84
	120103 Circuit card assembly (A3A2A1)	219	85
	120104 Circuit card assembly (A3A2A2) (Same as group 120103)		
	120105 Circuit card assembly (A3A2A3)	223	86
	120106 Circuit card assembly (A3A2A4)	227	87
	120107 Circuit card assembly (A3A2BO)	231	88
	120108 Circuit card assembly (A3A2B1)	235	89
	120109 Electrical component assembly (A3A2B2)	237	90
	120110 Circuit card assembly (A3A2B3)	241	91
	120111 Circuit card assembly (A3A2B4)	245	92
	120112 Chassis, electrical equipment (A3A2)	247	93
	12011201 Cable assembly (40640G1)	251	94
	12011202 Cable assembly(40638G1)	253	95
	13 Motor stop assembly (A5)	255	96
	1301 Circuit card assembly (A5A1)	259	97
	1302 Cable assembly (00-001585-2)	263	98
	1303 Circuit card assembly (A5A 2)	263	98
SECTION	III. Special tools list (Not applicable)		
	IV. National stock number and part number index	264	

**SECTION I
INTRODUCTION**

1. Scope

This manual lists spares and repair parts; special tools; special test, measurement, and diagnostic equipment (TMDE), and other special support equipment required for performance of the RO-315/G.

It authorizes the requisitioning and issue of spares and repair parts as indicated by the source and maintenance codes.

2. General

This Repair Parts and Special Tools List is divided into the following sections:

a. Section II. Repair Parts List. A list of spares and repair parts authorized for use in the performance of maintenance. The list also includes parts which must be removed for replacement of the authorized parts. Parts lists are composed of functional groups in numeric sequence, with the parts in each group listed in figure and item number sequence.

b. Section III. Special Tools List. Not applicable.

c. Section IV. National Stock Number and Part Number Index. A list, in National item identification number (NIIN) sequence, of all National stock numbers (NSN) appearing in the listings, followed by a list, in alphameric sequence, of all part numbers appearing in the listings. National stock numbers and part numbers are cross-referenced to each illustration figure and item number appearance.

3. Explanation of Columns

a. Illustration. This column is divided as follows:

(1) *Figure number.* Indicates the figure number of the illustration on which the item is shown.

(2) *Item number.* The number used to identify item called out in the illustration.

b. Source, Maintenance, and Recoverability (SMR) Codes.

(1) *Source code.* Source codes indicate the manner of acquiring support items for maintenance, repair, or overhaul of end items. Source codes are entered in the first and second positions of the Uniform SMR Code format as follows:

<i>Code</i>	<i>Definition</i>
-------------	-------------------

PA - Item procured and stocked for anticipated or known usage.
--

XA - Item is not procured or stocked because the
--

<i>Code</i>	<i>Definition</i>
-------------	-------------------

	requirements for the item will result in the replacement of the next higher assembly.
--	---

XD -	A support item that is not stocked. When required, item will be procured through normal supply channels.
------	--

NOTE

Cannibalization or salvage may be used as a source of supply for any items source coded above except those coded XA and aircraft support items as restricted by AR 700-42.

(2) *Maintenance code.* Maintenance codes are assigned to indicate the levels of maintenance authorized to USE and REPAIR support items. The maintenance codes are in the third and fourth positions of the Uniform SMR Code format as follows:

(a) The maintenance code entered in the third position will indicate the lowest maintenance level authorized to remove, replace, and use the support item. The maintenance code entered in the third position will indicate one of the following levels of maintenance:

<i>Code</i>	<i>Application/Explanation</i>
-------------	--------------------------------

H -	Support item is removed, replaced, used at the general support level.
-----	---

D -	Support items that are removed, replaced, used at depot, mobile depot, specialized repair activity only.
-----	--

(b) The maintenance code entered in the fourth position indicates whether the item is to be repaired and identifies the lowest maintenance level with the capability to perform complete repair (i.e., all authorized maintenance functions). This position will contain one of the following maintenance codes:

<i>Code</i>	<i>Application/Explanation</i>
-------------	--------------------------------

H -	The lowest maintenance level capable of complete repair of the support item is the general support level.
-----	---

D -	The lowest maintenance level capable of complete repair of the support item is the depot level.
-----	---

Z -	Nonreparable. No repair is authorized.
-----	--

(3) *Recoverability code.* Recoverability codes are assigned to support items to indicate the disposition action on unserviceable items. The recoverability code is entered in the fifth position of the Uniform SMR Code format as follows:

Recoverability

<i>Codes</i>	<i>Definition</i>
--------------	-------------------

- Z - Nonreparable item. When unserviceable, condemn and dispose at the level indicated in position 3.
- H - Repairable item. When uneconomically repairable, condemn and dispose at the general support level.
- D - Repairable item. When beyond lower level repair capability, return to depot. Condemnation and disposal not authorized below depot level.
- L - Repairable item. Repair, condemnation, and disposal not authorized below depot/specialized repair activity level.
 - c. *National Stock Number*-. Indicates the National stock number assigned to the item and ,will be used for requisitioning purposes.
 - d. *Part Number*. Indicates the primary number used by the manufacturer (individual, company, firm, corporation, or Government activity), which controls the design and characteristics of the item by means of its engineering drawings, specifications, standards, an inspection requirements to identify an item or range of items.

NOTE

When a stock numbered item is requisitioned, the repair part received may have a different part number than the part being replaced.

- e. *Federal Supply Code for Manufacture (FSCM)*. The FSCM is a 5-digit numeric code listed in SB 708-42 which is used to identify the manufacturer, distributor, or Government agency, etc.
- f. *Description*. Indicates the Federal item name and, if required, a minimum description to identify the item.
- g. *Unit of Measure (U/M)*. Indicates the standard of the basic quantity of the listed item as used in performing the actual maintenance function. This measure is expressed by a two-character alphabetical abbreviation (e.g., ea, in, pr, etc). When the unit of measure differs from the unit of issue, the lowest unit of issue that will satisfy the required units of measure will be requisitioned.
- h. *Quality Incorporated in Unit.*. Indicates the quantity of the item used in the breakout shown on the illustration figure, which is prepared for a functional group, subfunctional group, or an assembly. A "V" appearing in this column in lieu of a quantity indicates that no specific quantity is applicable, (e.g. shims, spacers, etc).

4. Special Information

- a. The following publication pertains to the RO-315/G and its components:
TM 11-7440-222-15, Paper Tape Punch, Low Speed RO-315iG.
- b. National stock numbers (NSN's) that are missing from P source coded items have been applied for and will be added to this TM by future change/revision when they are entered in the Army Master Data File (AMDF). Until the NSN's are established and published, submit exception requisitions to: Commander, US Army Communications and Electronics Materiel Readiness Command, ATTN: DRSEL-MM, Fort Monmouth, NJ 07703 for the part required to support your equipment.
- c. Action change codes indicated in the left-hand margin of the listing page denote the following:
 - N - Indicates an added item.
 - C - Indicates a change in data.
 - R - Indicates a change in NSN only.

5. How to Locate Repair Parts

- a. When National stock number or part number is unknown.
 - (1) *First*. Using the table of contents, determine the functional group within which the item belongs. This is necessary since illustrations are prepared for functional groups and listings are divided into the same groups.
 - (2) *Second*. Find the illustration covering the functional group to which the item belongs.
 - (3) *Third*. Identify the item on the illustration and note the illustration figure and item number of the item.
 - (4) *Forth*. Using the Repair Parts Listing, find the figure and item number noted on the illustration.
- b. When National stock number or part number is known.
 - (1) *First*. Using the Index of National Stock Numbers and Part Numbers, find the pertinent National stock number or part number. This index is in NIIN sequence followed by a list of part numbers in alphameric sequence, cross-referenced to the illustration figure number and item number.
 - (2) *Second*. After finding the figure and item number, locate the figure and item number in the repair parts list.

6. Abbreviations

Not applicable.

(Next printed page is 4.1)

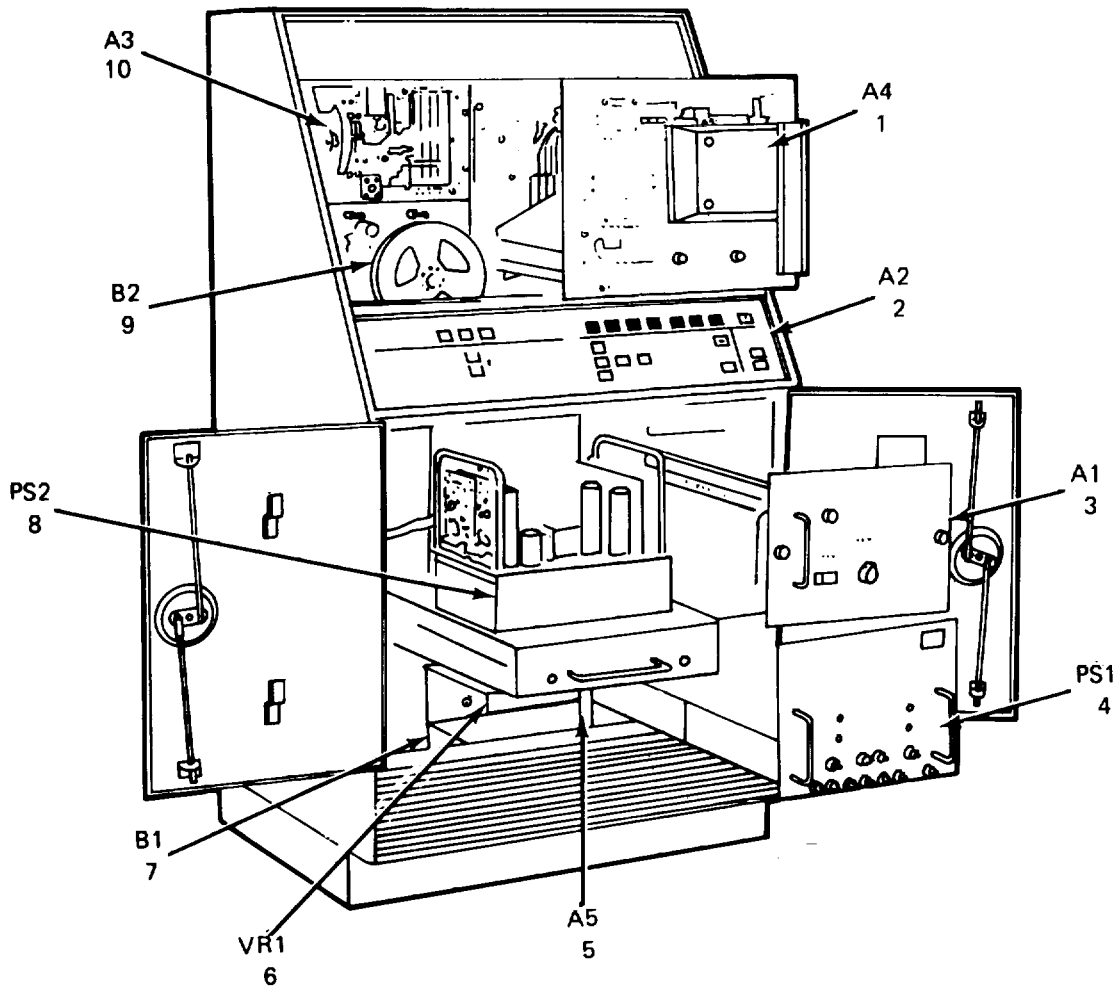

MAJOR ASSEMBLIES

ELOQM001

Figure 1. Paper Tape Punch, Low Speed R0-315/G (Sheet 1 of 4)

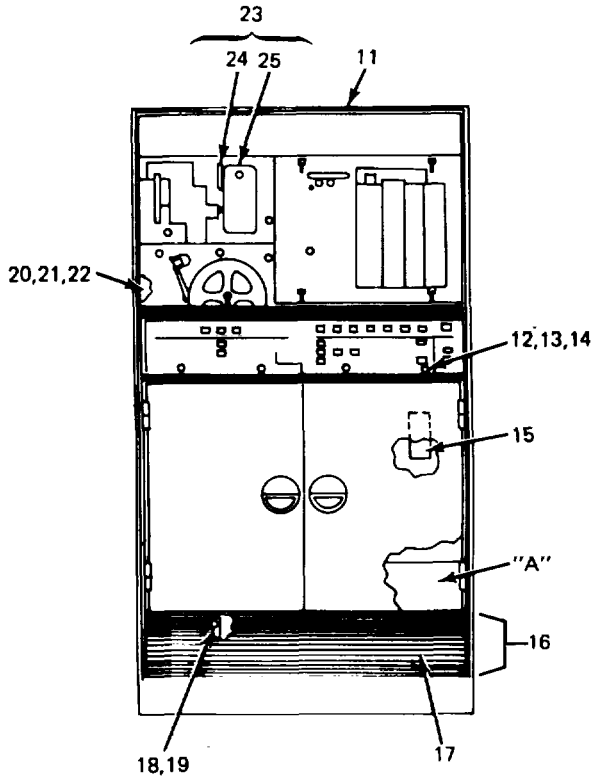

FRONT VIEW

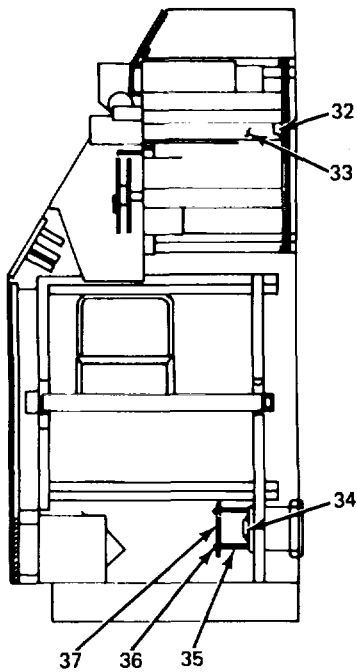
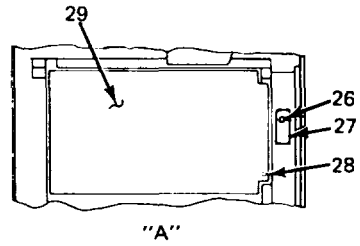

LEFT SIDE VIEW

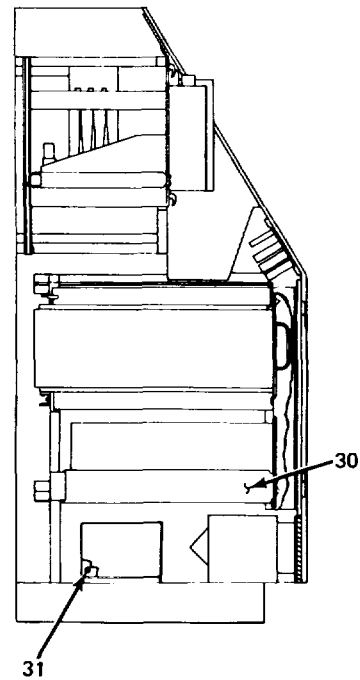

RIGHT SIDE VIEW

EL00M002

Figure 1. Paper Tape Punch, Low Speed RO-315/G (Sheet 2 of 4).

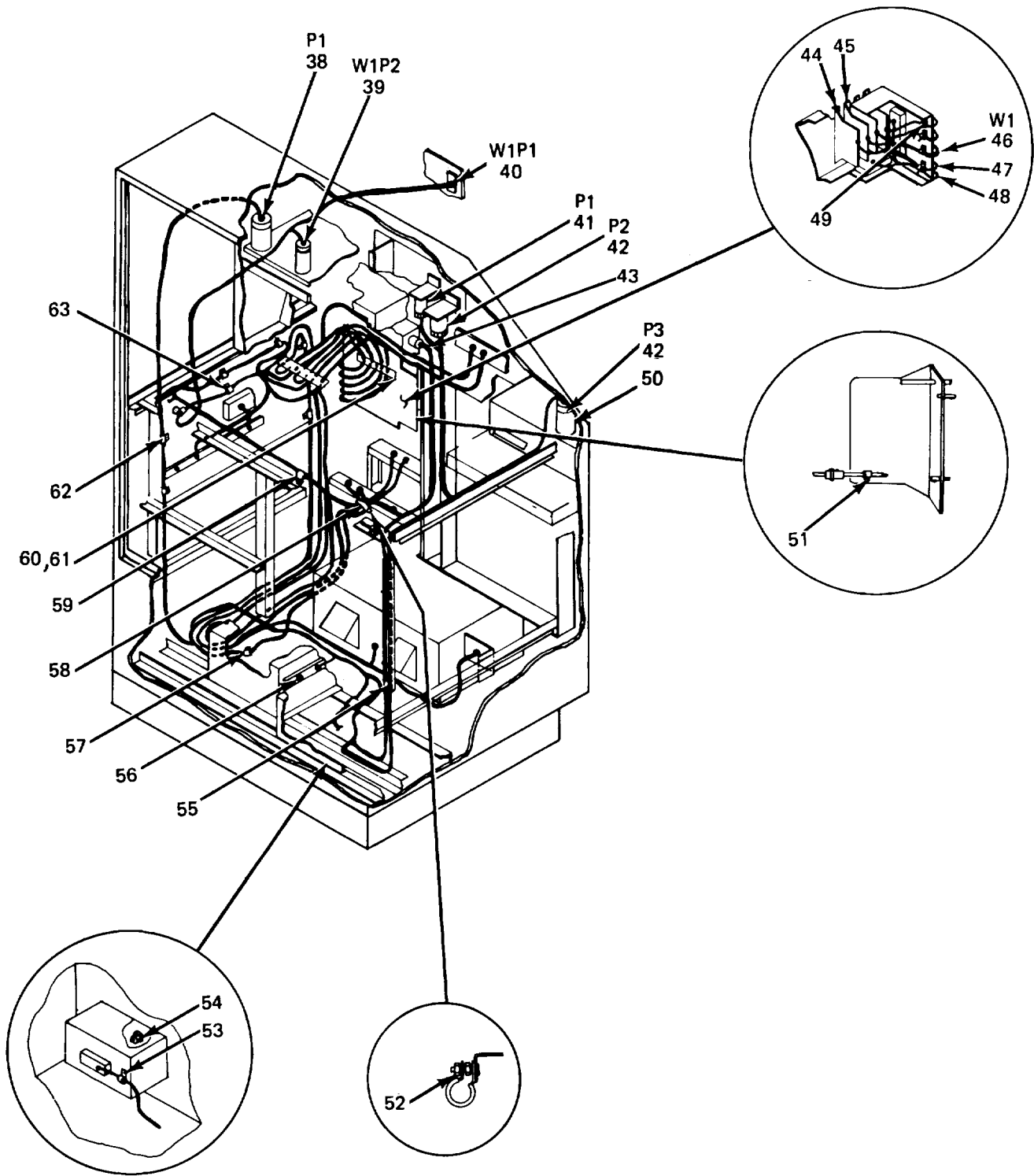

CABLE ASSEMBLIES

ELOQM003

Figure 1. Paper Tape Punch, Low Speed RO-315/G (Sheet 3 of 4).

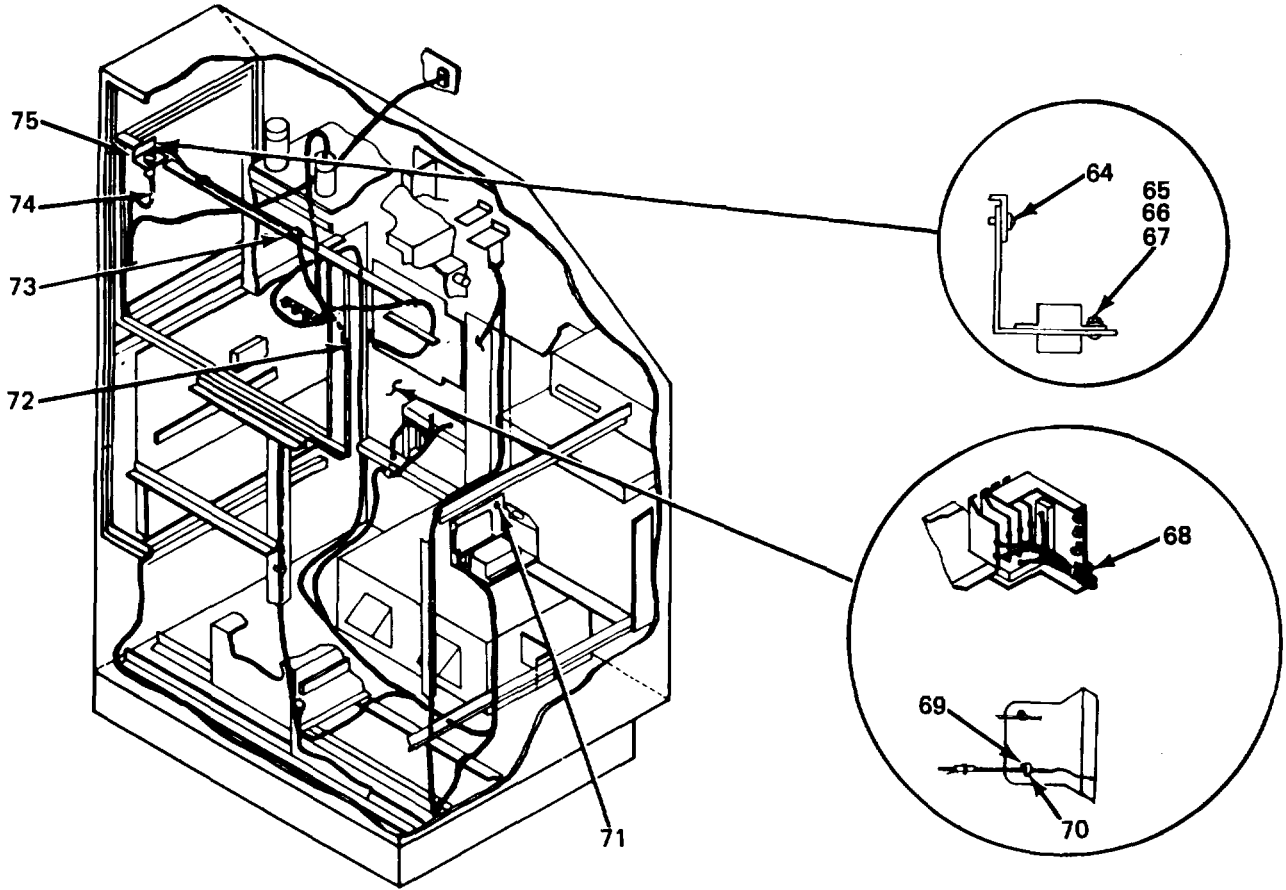

HARDWARE LOCATION

Figure 1. Paper Tape Punch, Low Speed RO-315/G (Sheet 4 of 4).

ELOQM004

SECTION II

TM 11-7440-222-40P/NAVELEX 0967-LP-324-0480/TO 31W4-2G-84

(1) ILLUSTRATION		(2)	(3)	(4)	(5)	(6) DESCRIPTION	(7)	(8)
(a) FIG NO.	(b) ITEM NO.	SMR CODE	NATIONAL STOCK NUMBER	PART NUMBER	FSCM	USABLE ON CODE	U/M	QTY INC IN UNIT
						GROUP 00 PAPER TAPE PUNCH.LOW SPEED RO-315/G		
1	1	XDHHH	7040-00-334-6006	A64509-001	12436	PUNCH ASSEMBLY.....	EA	1
1	2	XDHHH		A64505-001	58189	CONTROL,PANEL	EA	1
1	3	XDHHH		A64504-001	58189	LOGIC ASSEMBLY	EA	1
1	4	XDHHH		40-000093-1	06809	POWER SUPPLY	EA	1
1	5	XDHHH		00-001563-5	06809	MOTOR STOP ASSEMBLY	EA	1
1	6	PAHHH	5950-00-102-5675	W-7712-3-5A	08715	TRANSFORMER,POWER,S	EA	1
1	7	XDHHH		RC2EB412A31	03522	FAN,CENTRIFUGAL	EA	1
1	8	XDHHH		A64538-001	58189	POWER SUPPLY ASSY	EA	1
1	9	XDHHH		373620	12344	TAPE REELER	EA	1
1	10	PAHHH	7025-00-165-6532	15521G1	12436	PRINTER INTERPRETER.....	EA	1
1	11	XDHHH		600501-1	05439	ENCLOSURE	EA	1
1	12	PAHZZ	5305-00-054-6669	MS51957-44	96906	SCREW,MACHINE.....	EA	1
1	13	PAHZZ	5310-00-558-6207	AN960C8L	88044	WASHER,FLAT	EA	4
1	14	PAHZZ	5310-00-933-8119	MS35338-137	96906	WASHER,LOCK	EA	4
1	15	XDHZZ		A64548-001	58189	PLATE,IDENT	EA	1
1	16	XDHHH		SMB634754	80063	GRILL ASSEMBLY	EA	1
1	17	XDHZZ		SMD546276-1	80063	GRILL	EA	1
1	18	XDHZZ		C1663-017-24	88813	STUD,TURNLOCK FSTNR	EA	2
1	19	PAHZZ	5310-00-982-6813	MS21044C06	96906	NUT SELF-LOCKING,HE	EA	2
1	20	PAHZZ	5310-00-933-8120	MS35338-138	96906	WASHER,LOCK	EA	2
1	21	PAHZZ	5310-00-167-0812	AN960C10L	88044	WASHER,FLAT	EA	1
1	22	PAHZZ	5305-00-059-3660	MS51958-64	96906	SCREW,MACHINE.....	EA	1
1	23	XDHHH		A64543-001	58189	PANEL ASSEMBLY	EA	1
1	24	PAHZZ	5340-00-684-9956	49-1-1-0	94222	LATCH SET,RIM	EA	1
1	25	XDHZZ		A64550-001	58189	PANEL.....	EA	1
1	26	XDHZZ	5305-00-253-5603	MS21318-1	96906	SCREW,DRIVE	EA	2
1	27	XDHZZ		A53909-001	58189	PLATE,IDENT	EA	1
1	28	PAHZZ	5305-00-054-6670	MS51957-45	96906	SCREW,MACHINE.....	EA	1
1	29	XDHHH		A61665-001	58189	PLATE,INTERFACE	EA	1
1	30	XDHZZ		C230622	88813	SLIDE	EA	1
1	31	PAHZZ	5305-00-059-3657	MS51958-61	96906	SCREW,MACHINE.....	EA	6
1	32	XDHZZ		SMB634803	80063	SCREW,MACHINE	EA	20
1	33	XDHZZ		C300S14	06666	SLIDE,DRAWER,EXTENS	EA	1
1	34	XDHHH		A64008-001	58189	FLTER ASSEMBLY	EA	1
1	35	XDHZZ		D1-1098581	14850	STANDOFF	EA	6
1	36	XDHZZ		A1-10977F-6	14850	SCREW,MACHINE	EA	6
1	37	XDHZZ		A1-10979C	14850	SHIELD ASSEMBLY	EA	1
1	38	PAHZZ	5935-00-102-8101	CA06R28-20S	71468	CONNECTOR,PLUG,ELEC	EA	1
					5			

SECTION II

TM 11-7440-222-40P/NAVELEX 0967-LP-324-0480/TO 31W4-2G-84

(1) ILLUSTRATION		(2)	(3)	(4)	(5)	(6) DESCRIPTION	(7)	(8)
(a) FIG NO.	(b) ITEM NO.	SMR CODE	NATIONAL STOCK NUMBER	PART NUMBER	FSCM	USABLE ON CODE	U/M	QTY INC IN UNIT
1	39	XDHZZ		25026-165GDS	95238	CONNECTOR,RCPT,ELEC.....	EA	1
1	40	PAHZZ	5935-00-726-4525	CA06R22-14S	71468	CONNECTOR,PLUG,ELEC.....	EA	1
1	41	XDHZZ		CA06R24-28S	71468	CONNECTOR,PLUG,ELEC.....	EA	1
1	42	PAHZZ	5935-00-727-2134	CA06R28-12S	71468	CONNECTOR,PLUG,ELEC.....	EA	2
1	43	XDHZZ		559998	12436	CONNECTOR,PLUG,ELEC.....	EA	1
1	44	PAHZZ	5999-00-933-5070	A53847-001	58189	CONTACT ASSEMBLY,EL.....	EA	1
1	45	PAHZZ	5999-00-933-5070	A53847-001	58189	CONTACT ASSEMBLY,EL.....	EA	1
1	46	XDHHH		A65413-001	58189	CABLE ASSEMBLY.....	EA	1
1	47	XDHHH		A65415-001	58189	WIRING HARNESS.....	EA	1
1	48	XDHHH		A65409-001	58189	WIRING HARNESS.....	EA	1
1	49	XDHZZ	5340-00-560-9262	HP13N	09922	CLAMP,LOOP.....	EA	1
1	50	PAHZZ	5940-00-113-8199	2-323934-2	00779	FERRULE.....	EA	1
1	51	XDHZZ	5340-00-336-8164	HP10N	09922	CLAMP,LOOP.....	EA	1
1	52	PAHZZ	5310-00-614-3552	MS35335-59	96906	WASHER,LOCK.....	EA	6
1	53	XDHZZ	5340-00-337-8642	HP-9N	09922	CLAMP,LOOP.....	EA	1
1	54	PAHZZ	5310-00-934-9759	MS35649-284	96906	NUT,PLAIN,HEXAGON.....	EA	1
1	55	XDHZZ		HP-5N	12357	CLAMP,LOOP.....	EA	2
1	56	PAHZZ	5940-00-813-0698	MS25036-1	96906	TERMINAL,LUG.....	EA	1
1	57	XDHZZ	5340-00-698-3440	HP-16N	09922	CLAMP,LOOP.....	EA	2
1	58	XDHZZ		SMC634831-3	80063	CLAMP,LOOP.....	EA	1
1	59	XDHZZ		HP-8N	12357	CLAMP,LOOP.....	EA	5
1	60	PAHZZ	5310-00-934-9765	MS35650-304	96906	NUT,PLAIN,HEXAGON.....	EA	1
1	61	XDHZZ		SMC634816	80063	BAR,CLAMP.....	EA	1
1	62	XDHZZ	5340-00-336-8164	HP10N	09922	CLAMP,LOOP.....	EA	1
1	63	XDHZZ	5340-00-290-7273	HP-I2N	09922	CLAMP,LOOP.....	EA	8
1	64	PADZZ	5305-00-059-3659	MS51958-63	96906	SCREW,MACHINE.....	EA	1
1	65	PADZZ	5310-00-934-9748	MS35649-244	96906	NUT,PLAIN,HEXAGON.....	EA	5
1	66	PADZZ	5310-00-595-6425	AN960C4L	88044	WASHER,FLAT.....	EA	1
1	67	PADZZ	5305-00-054-5651	MS51957-17	96906	SCREW,MACHINE.....	EA	1
1	68	XDHZZ		CPC1953-16B	71616	CLAMP,CABLE.....	EA	2
1	69	PAHZZ	5340-00-003-9207	HP-4N	09922	CLAMP,CABLE.....	EA	1
1	70	PAHZZ	5305-00-768-0336	MS1959-17	96906	SCREW,MACHINE.....	EA	1
1	71	XDDZZ		01-002884-1	06809	NUT,BAR.....	EA	1
1	72	PAHZZ	5340-00-439-5246	CPC1953-12B	71616	CLAMP,LOOP.....	EA	2
1	73	PAHZZ	5340-00-257-0038	CPC1953-2A	71616	CLAMP,LOOP.....	EA	2
1	74	XDDZZ		01-002980-1	06809	NAMEPLATE.....	EA	1
1	75	XDDZZ		01-002906-1	06809	CONNECTOR,MTG BRKT.....	EA	1
6/(7 blank)								

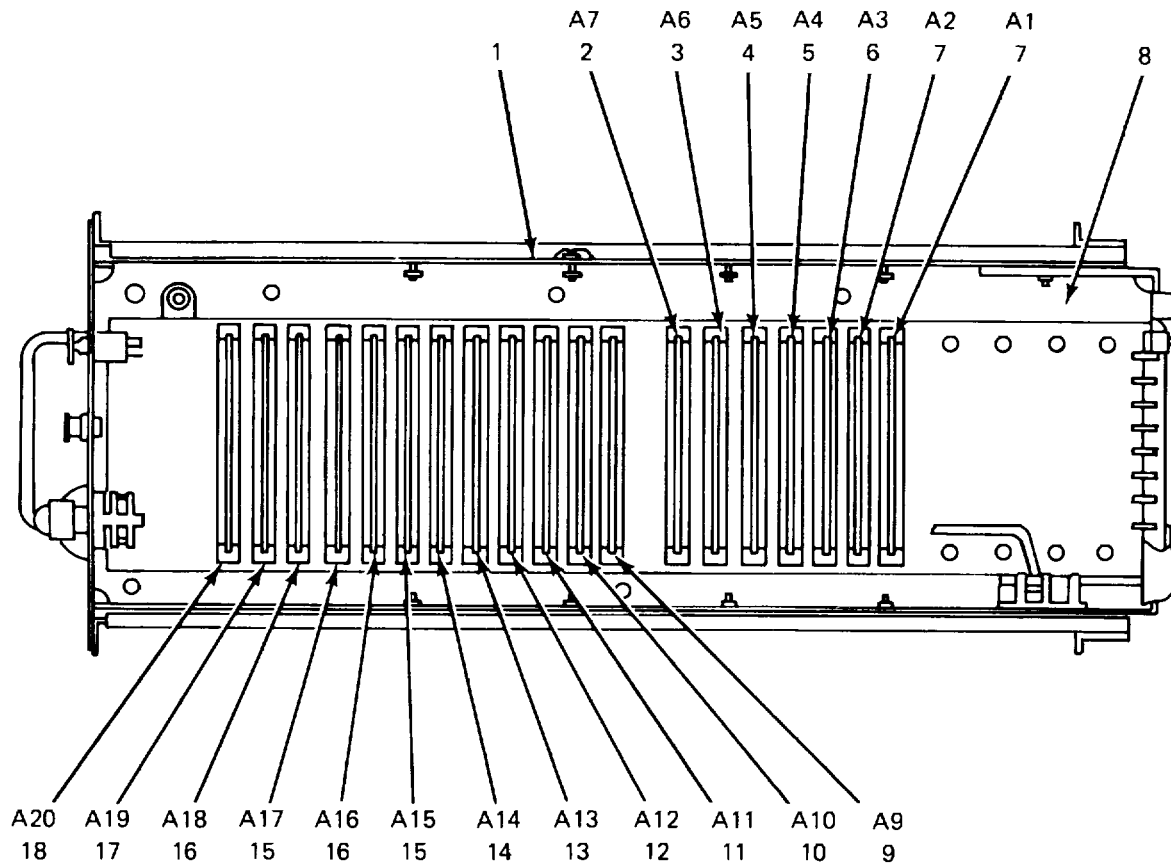

NOTE: PREFIX ALL REFERENCE DESIGNATIONS WITH A1

EL0QM005

Figure 2. Logic Assembly A1.

SECTION II

TM 11-7440-222-40P/NAVELEX 0967-LP-324-0480/TO 31W4-2G-84

(1) ILLUSTRATION		(2)	(3)	(4)	(5)	(6) DESCRIPTION	(7)	(8)
(a) FIG NO.	(b) ITEM NO.	SMR CODE	NATIONAL STOCK NUMBER	PART NUMBER	FSCM	USABLE ON CODE	U/M	QTY INC IN UNIT
						GROUP 01 LOGIC ASSEMBLY A1		
2	1	XDHZZ		A61707-003	58189	PLATE,DESIGNATOR	EA	1
2	2	PAHDL	5999-00-935-2377	A65369-001	12436	CIRCUIT CARD ASSEMB.....	EA	1
2	3	PAHDL	5999-00-935-2384	A65365-001	12436	CIRCUIT CARD ASSEMB.....	EA	1
2	4	PAHDL	5999-00-935-2382	A65361-001	12436	CIRCUIT CARD ASSEMB.....	EA	1
2	5	PAHDL	5999-00-935-2381	A65393-001	12436	CIRCUIT CARD ASSEMB.....	EA	1
2	6	PAHDL	5999-00-935-2388	A65397-001	12436	CIRCUIT CARD ASSEMB.....	EA	1
2	7	PAHDL	5999-00-935-2387	A65201-001	12436	CIRCUIT CARD ASSEMB.....	EA	2
2	7	XDHDL		A65219-001	58189	CIRCUIT CARD ASSY	EA	2
2	8	XDHHH		A64504-002	58189	LOGIC CHASSIS.....	EA	1
2	9	PAHDL	5999-00-935-2378	A65377-001	12436	CIRCUIT CARD ASSEMB.....	EA	1
2	10	PAHDL	5999-00-935-2385	A65385-001	12436	CIRCUIT CARD ASSEMB.....	EA	1
2	11	PAHDL	5999-00-935-2386	A65389-001	12436	CIRCUIT CARD ASSEMB.....	EA	1
2	12	PAHDL	5999-00-935-2383	A53584-001	12436	CIRCUIT CARD ASSEMB.....	EA	1
2	13	PAHDL	7040-00-911-1619	A65441-001	12436	CIRCUIT CARD ASSEMB.....	EA	1
2	14	PAHDL	7040-00-911-2501	A53418-001	12436	CIRCUIT CARD ASSEMB.....	EA	1
2	15	PAHDL	7040-00-911-1615	A53725-001	12436	CIRCUIT CARD ASSEMB.....	EA	2
2	16	PAHDL	7040-00-911-1145	A53721-001	12436	CIRCUIT CARD ASSEMB.....	EA	2
2	17	PAHDL	5999-00-935-2379	A65373-001	12436	CIRCUIT CARD ASSEMB.....	EA	1
2	18	PAHDL	5999-00-935-2380	SME546656	80063	CIRCUIT CARD ASSEMB.....	EA	1
					9			

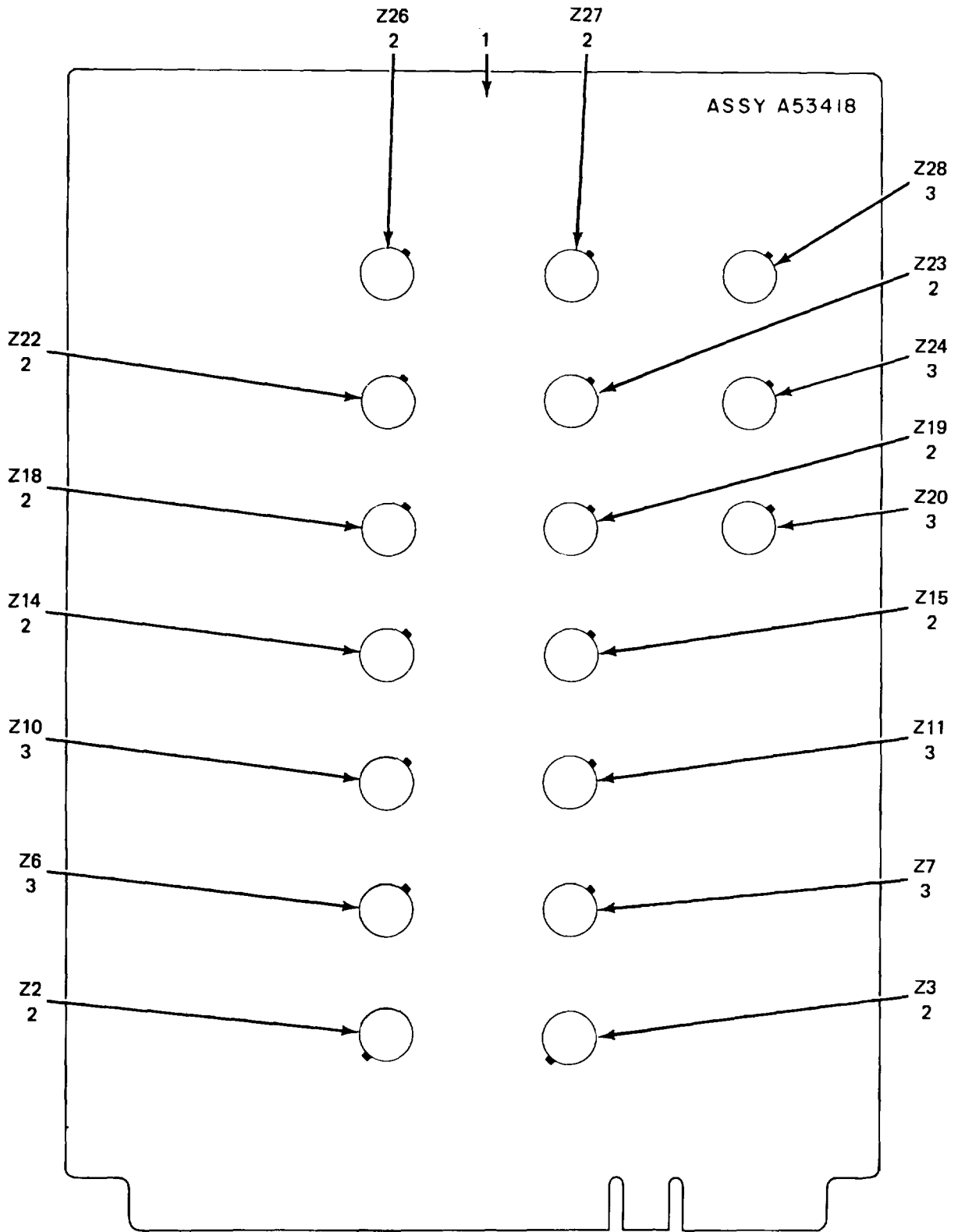

NOTE: PREFIX ALL REFERENCE DESIGNATIONS WITH A1A14

EL0QM006

Figure 3. Circuit Card Assembly A1A14.

SECTION II

TM 11-7440-222-40P/NAVELEX 0967-LP-324-0480/TO 31W4-2G-84

(1) ILLUSTRATION		(2)	(3)	(4)	(5)	(6)	(7)	(8)
(a) FIG NO.	(b) ITEM NO.	SMR CODE	NATIONAL STOCK NUMBER	PART NUMBER	FSCM	DESCRIPTION USABLE ON CODE	U/M	QTY INC IN UNIT
						GROUP 0101 CIRCUIT CARD ASSEMBLY A1A14		
3	1	XDDZZ		A53419-00L	58189	PRINTED CIRCUIT	EA	1
3	2	PADZZ	5962-00-791-0994	C7580K	18324	MICROCIRCUIT,DIGITA	EA	10
3	3	PADZZ	5962-00-791-1082	C7090K	18324	MICROCIRCUIT,DIGITA	EA	7
					11			

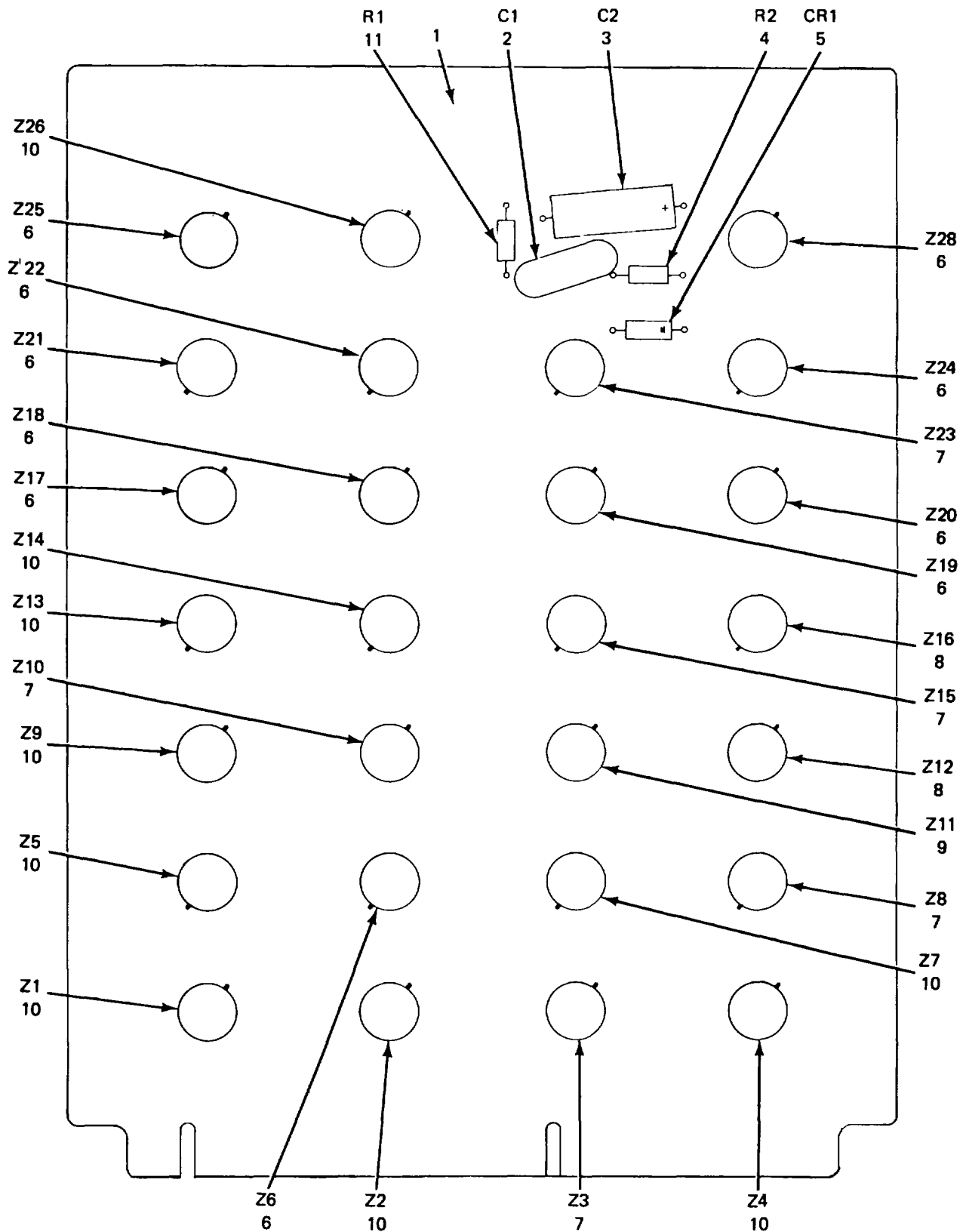

NOTE: PREFIX ALL REFERENCE DESIGNATIONS WITH A1A13

EL0QM007

Figure 4. Circuit Card Assembly A1A13.

SECTION II

TM 11-7440-222-40P/NAVELEX 0967-LP-324-0480/TO 31W4-2G-84

(1) ILLUSTRATION		(2)	(3)	(4)	(5)	(6)	(7)	(8)
(a) FIG NO.	(b) ITEM NO.	SMR CODE	NATIONAL STOCK NUMBER	PART NUMBER	FSCM	DESCRIPTION USABLE ON CODE	U/M	QTY INC IN UNIT
						GROUP 0102 CIRCUIT CARD ASSEMBLY A1A13		
4	1	XDDZZ		A65442-001	58189	PRINTED CIRCUIT BD	EA	1
4	2	PADZZ	5910-00-043-2933	CM06F821J03	81349	CAPACITOR, FIXED, MIC	EA	1
4	3	PADZZ	5910-00-412-9235	M39003-01-2981	81349	CAPACITOR.....	EA	1
4	4	PADZZ	5905-00-702-4439	RC07GF133J	81349	RESISTOR, FIXED, COMP.....	EA	1
4	5	PADZZ	5961-00-814-0768	JAN1N3064	81349	SEMICONDUCTOR DEVIC.....	EA	1
4	6	PADZZ	5962-00-791-1082	C7090K	18324	MICROCIRCUIT, DIGITA	EA	9
4	7	PADZZ	5962-00-167-7897	C7088K	18324	MICROCIRCUIT, DIGITA	EA	5
4	8	PADZZ	5962-00-791-1393	C7091K	18324	MICROCIRCUIT, DIGITA	EA	2
4	9	PADZZ	5962-00-791-1004	C7089K	18324	MICROCIRCUIT, DIGITA	EA	1
4	10	PADZZ	5962-00-791-0994	C7580K	18324	MICROCIRCUIT, DIGITA	EA	9
4	11	PADZZ	5905-00-801-6444	RC07GF911J	81349	RESISTOR, FIXED, COMP	EA	1
					13			

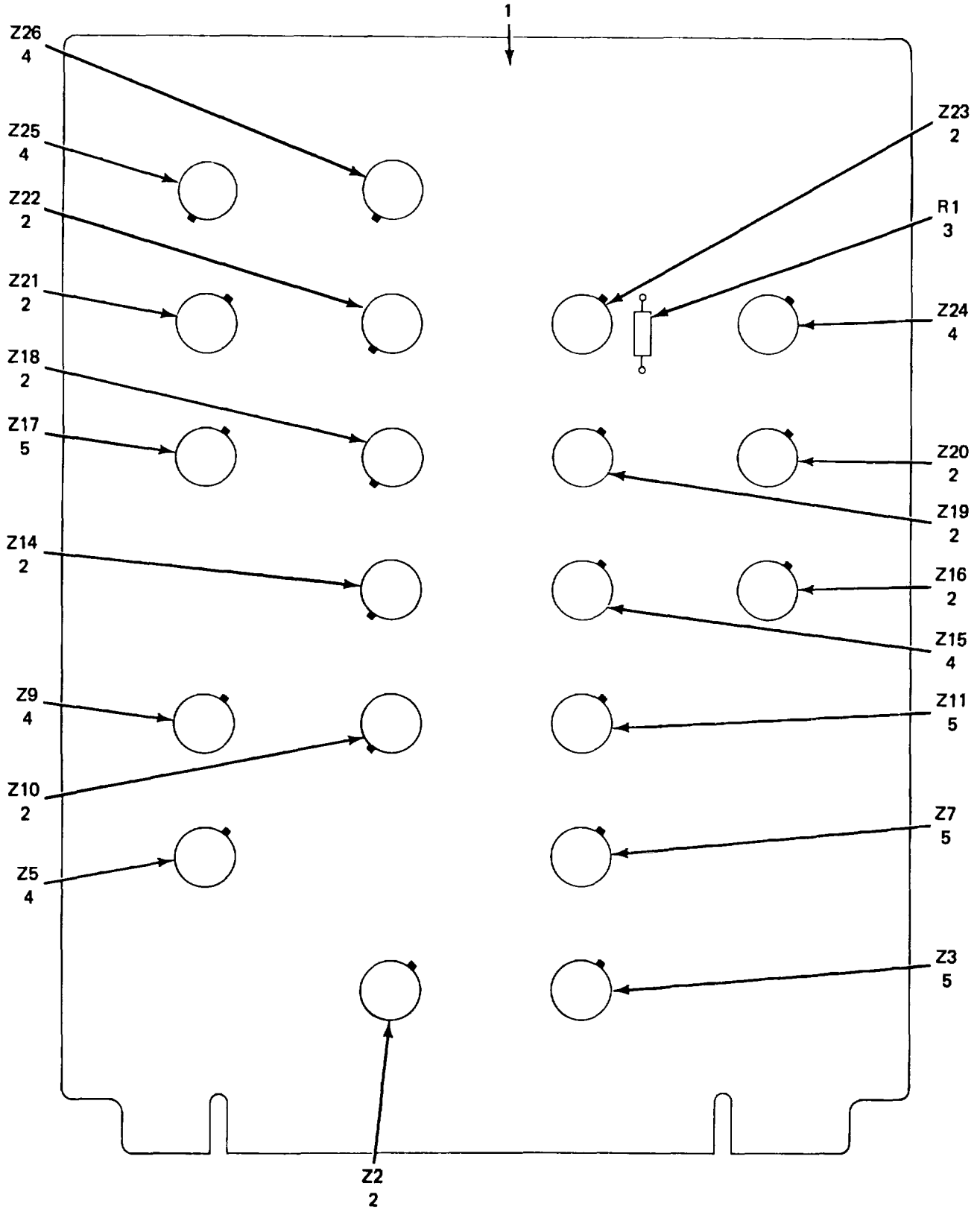

NOTE: PREFIX ALL REFERENCE DESIGNATIONS WITH A1A12

EL00M008

Figure 5. Circuit Card Assembly A1A12.

SECTION II

TM 11-7440-222-40P/NAVELEX 0967-LP-324-0480/TO 31W4-2G-84

(1) ILLUSTRATION		(2)	(3)	(4)	(5)	(6)	(7)	(8)
(a) FIG NO.	(b) ITEM NO.	SMR CODE	NATIONAL STOCK NUMBER	PART NUMBER	FSCM	DESCRIPTION USABLE ON CODE	U/M	QTY INC IN UNIT
						GROUP 0103 CIRCUIT CARD ASSENIPLY A1A12		
5	1	XDDZZ		A53585-001	58189	PRINTED CIRCUIT BD	EA	1
5	2	PADZZ	5962-00-791-0994	C7580K	18324	MICROCIRCUIT,DIGIT	EA	10
5	3	PADZZ	5905-00-723-5251	RC07GF222J	81349	RESISTOR,FIXED,COMP	EA	1
5	4	PADZZ	5962-00-791-1082	C7090K	18324	MICROCIRCUIT,DIGITA	EA	6
5	5	PADZZ	5962-00-167-7897	C7088K	18324	MICROCIRCUIT,DIGITA	EA	4
					15			

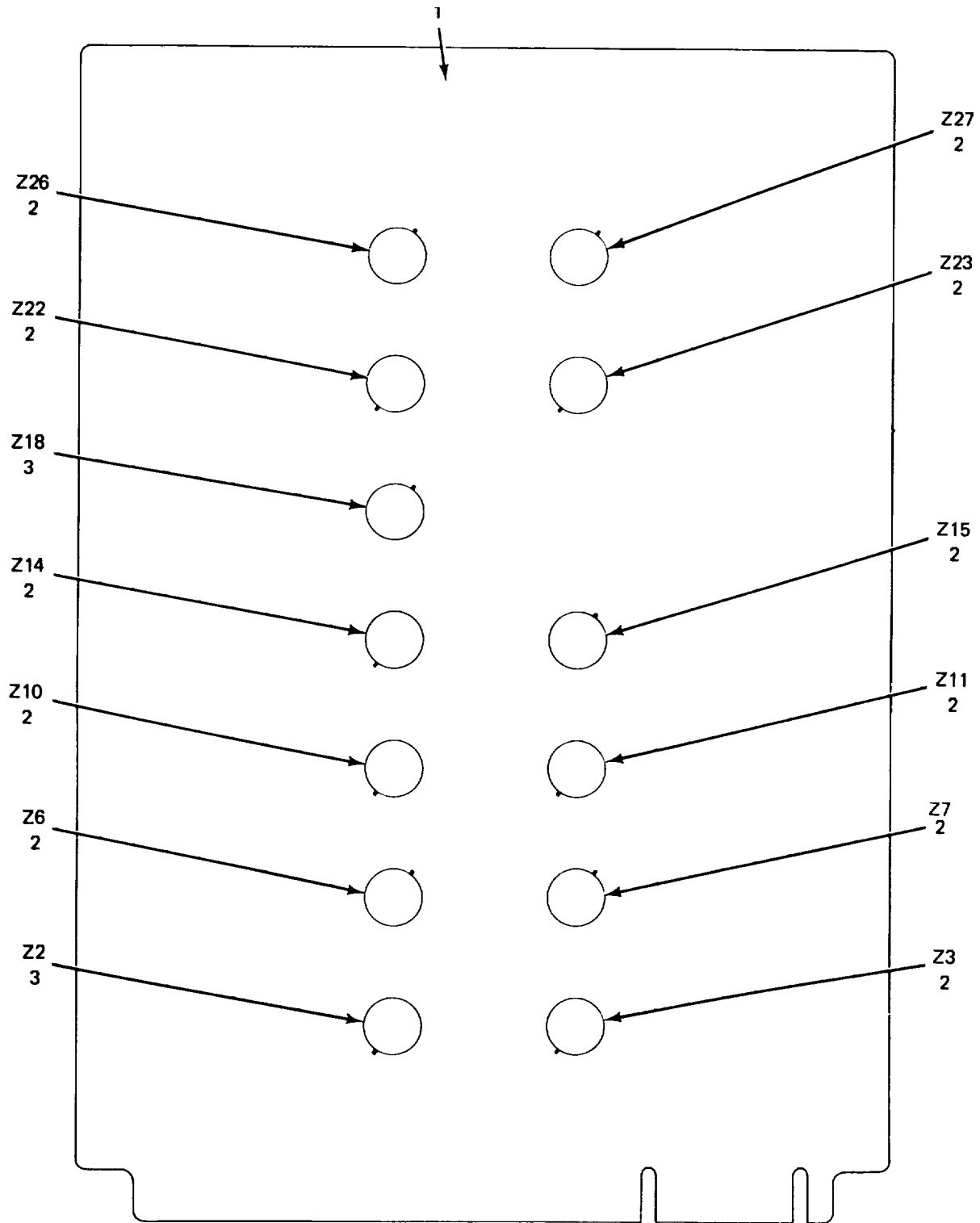

NOTE: PREFIX ALL REFERENCE DESIGNATIONS WITH A1A16 OR A1A18

ELOQM009

Figure 6. Circuit Card Assembly A1A16.

SECTION II

TM 11-7440-222-40P/NAVELEX 0967-LP-324-0480/TO 31W4-2G-84

(1) ILLUSTRATION		(2)	(3)	(4)	(5)	(6)	(7)	(8)
(a) FIG NO.	(b) ITEM NO.	SMR CODE	NATIONAL STOCK NUMBER	PART NUMBER	FSCM	DESCRIPTION USABLE ON CODE	U/M	QTY INC IN UNIT
						GROUP 0104 CIRCUIT CARD ASSEM#LY A1A16		
6	1	XDDZZ		A53722-001	58189	PRINTED CIRCUIT, BD	EA	1
6	2	PADZZ	5962-00-791-1048	C7577K	18324	MICROCIRCUIT,DIGITA	EA	11
6	3	PADZZ	5962-00-791-1120	C7579K	18324	MICROCIRCUIT,DIGITA	EA	2
					17			

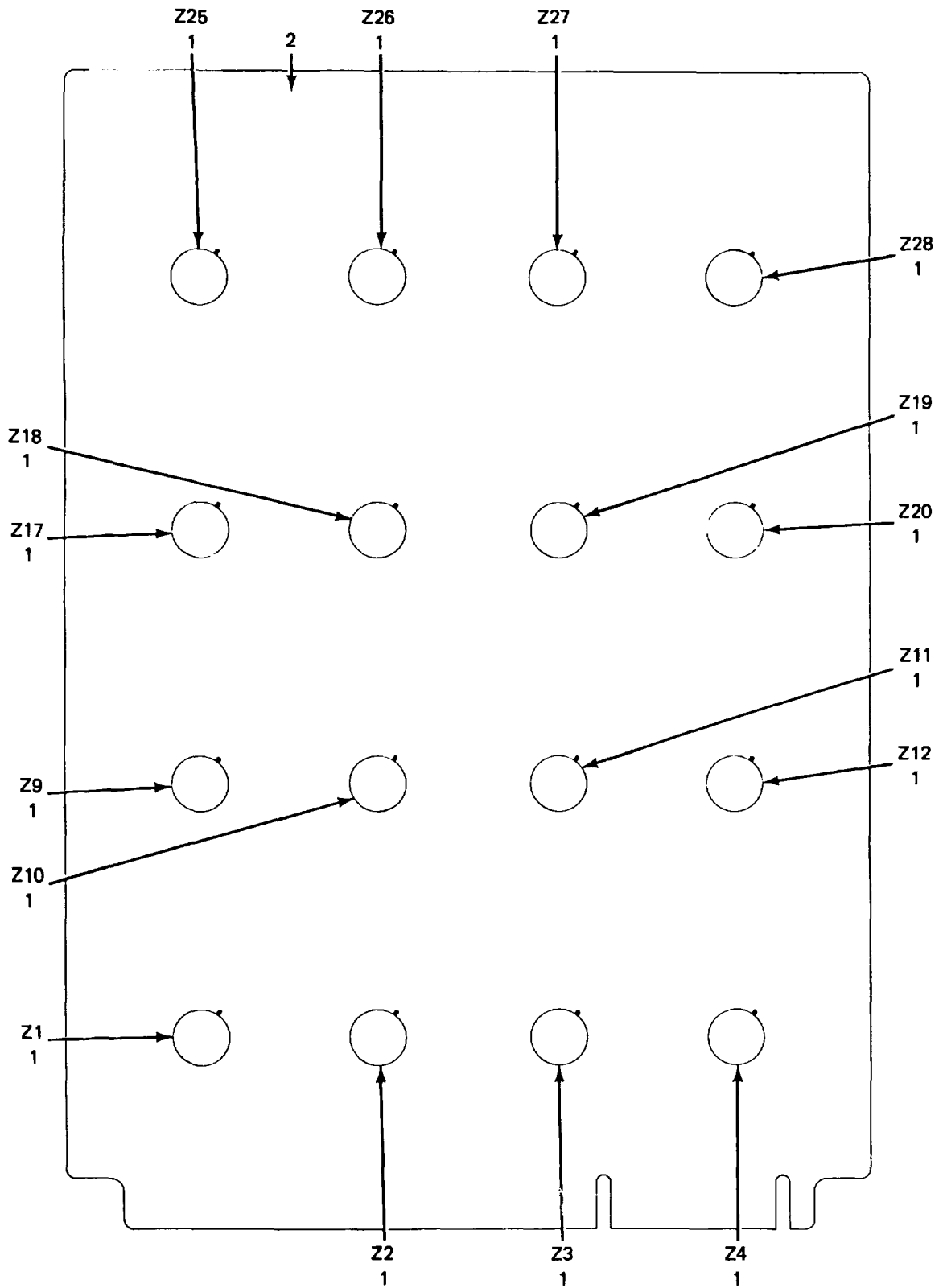

NOTE: PREFIX ALL REFERENCE DESIGNATIONS WITH A1A15 OR A1A17

EL0QM010

Figure 7. Circuit Card Assembly A1A15.

SECTION II

TM 11-7440-222-40P/NAVELEX 0967-LP-324-0480/TO 31W4-2G-84

(1) ILLUSTRATION		(2)	(3)	(4)	(5)	(6)	(7)	(8)
(a) FIG NO.	(b) ITEM NO.	SMR CODE	NATIONAL STOCK NUMBER	PART NUMBER	FSCM	DESCRIPTION USABLE ON CODE	U/M	QTY INC IN UNIT
7	1	PADZZ	5962-00-791-1082	C7090K	18324	GROUP 0106 CIRCUIT CARD ASSEMBLY A1A15	EA	16
7	2	XDDZZ		A53726-001	58189	MICROCIRCUIT,DIGITA PRINTED CIRCUIT BD	EA	1
19/(20 blank)								

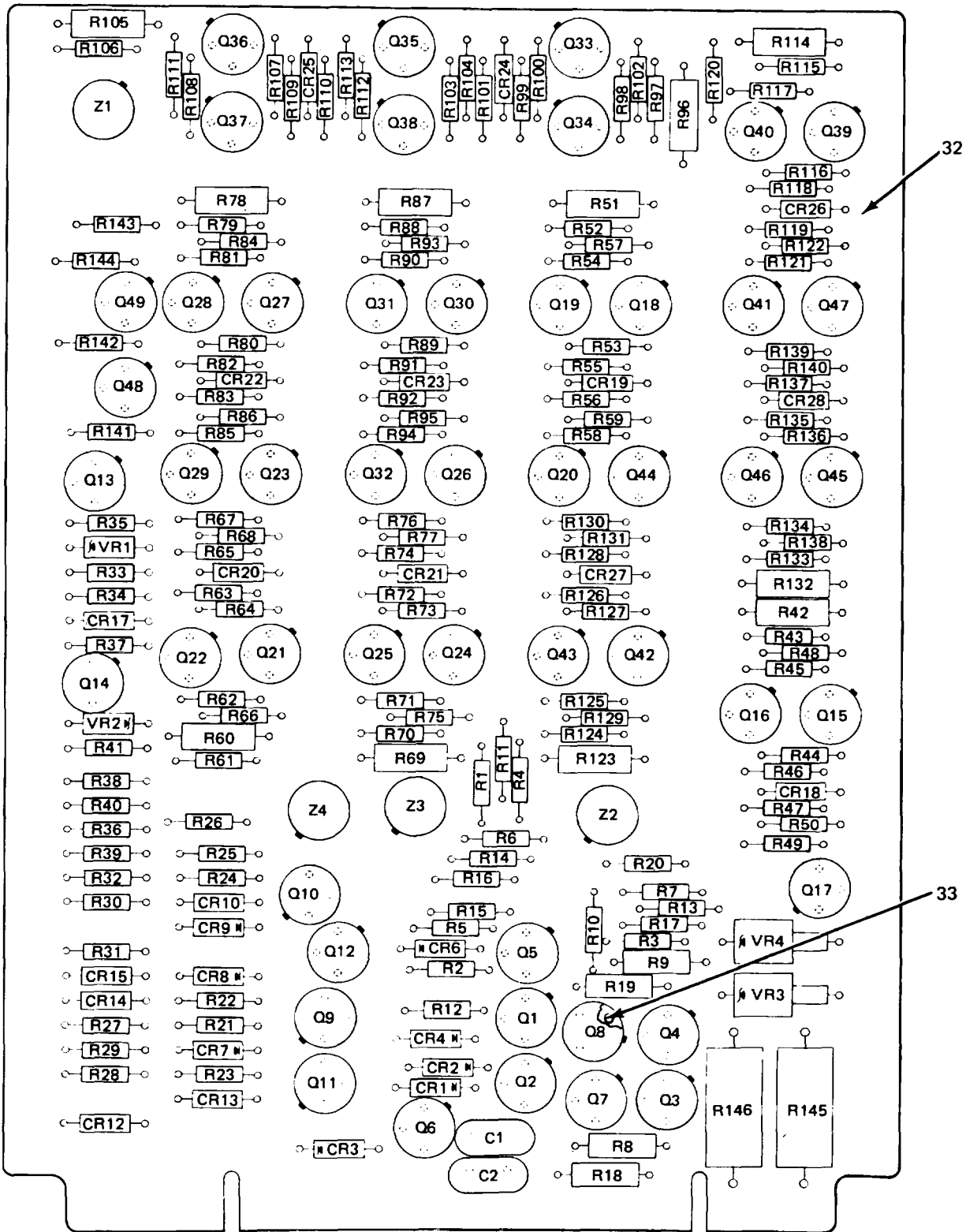

CIRCUIT CARD NO. 65201-001

NOTE: PREFIX ALL REFERENCE DESIGNATIONS WITH A1A1 OR A1A2

EL00M011

Figure 8. Circuit Card Assembly A1A1 (Sheet 1 of 4).

REF. DES.	ITEM NO.	REF. DES.	ITEM NO.	REF. DES.	ITEM NO.	REF. DES.	ITEM NO.	REF. DES.	ITEM NO.	REF. DES.	ITEM NO.	REF. DES.	ITEM NO.
C1	1	CR20	2	Q10	3	Q28	3	Q46	3	R15	9	R33	17
C2	1	CR21	2	Q11	3	Q29	3	Q47	3	R16	10	R34	18
CR1	2	CR22	2	Q12	3	Q30	3	Q48	3	R17	1	R35	19
CR2	2	CR23	2	Q13	3	Q31	3	Q49	3	R18	12	R36	20
CR3	2	CR24	2	Q14	3	Q32	3	R1	5	R19	12	R37	21
CR4	2	CR25	2	Q15	3	Q33	3	R2	6	R20	13	R38	17
CR6	2	CR26	2	Q16	3	Q34	3	R3	7	R21	14	R39	18
CR7	2	CR27	2	Q17	3	Q35	3	R4	8	R22	15	R40	20
CR8	2	CR28	2	Q18	3	Q36	3	R5	9	R23	16	R41	21
CR9	2	Q1	3	Q19	3	Q37	3	R6	10	R24	14	R42	22
CR10	2	Q2	4	Q20	3	Q38	3	R7	11	R25	15	R43	23
CR12	2	Q3	3	Q21	3	Q39	3	R8	12	R26	16	R44	11
CR13	2	Q4	4	Q22	3	Q40	3	R9	12	R27	14	R45	11
CR14	2	Q5	3	Q23	3	Q41	3	R10	13	R28	15	R46	24
CR15	2	Q6	4	Q24	3	Q42	3	R11	5	R29	16		
CR17	2	Q7	3	Q25	3	Q43	3	R12	6	R30	14		
CR18	2	Q8	4	Q26	3	Q44		R13	7	R31	15		
CR19	2	Q9	3	Q27	3	Q45		R14	8	R32	16		

EL0QM012

Figure 8. Circuit Card Assembly A1A1 (Sheet 2 of 4).

REF. DES.	ITEM NO.	REF. DES.	ITEM NO.	REF. DES.	ITEM NO.	REF. DES.	ITEM NO.	REF. DES.	ITEM NO.	REF. DES.	ITEM NO.	REF. DES.	ITEM NO.
R47	9	R63	11	R79	23	R95	25	R111	23	R127	24	R143	26
R48	23	R64	24	R80	11	R96	22	R112	7	R128	9	R144	15
R49	7	R65	9	R81	11	R97	23	R113	25	R129	23	R145	27
R50	25	R66	23	R82	24	R98	11	R114	22	R130	7	R146	27
R51	22	R67	7	R83	9	R99	11	R115	23	R131	25	VR1	28
R52	23	R68	25	R84	23	R100	24	R116	11	R132	22	VR2	28
R53	11	R69	22	R85	7	R101	9	R117	11	R133	23	VR3	29
R54	11	R70	23	R86	25	R102	23	R118	24	R134	11	VR4	29
R55	24	R71	11	R87	22	R103	7	R119	9	R135	11	Z1	30
R56	9	R72	11	R88	23	R104	25	R120	23	R136	24	Z2	30
R57	23	R73	24	R89	11	R105	22	R121	7	R137	9	Z3	30
R58	7	R74	9	R90	11	R106	23	R122	25	R138	23	Z4	31
R59	25	R75	23	R91	24	R107	11	R123	22	R139	7		
R60	22	R76	7	R92	9	R108	11	R124	23	R140	25		
R61	23	R77	25	R93	23	R109	24	R125	11	R141	26		
R62	11	R78	22	R94	7	R110	9	R126	11	R142	15		

FI 00M013

Figure 8. Circuit Card Assembly A1A1 (Sheet 3 of 4).

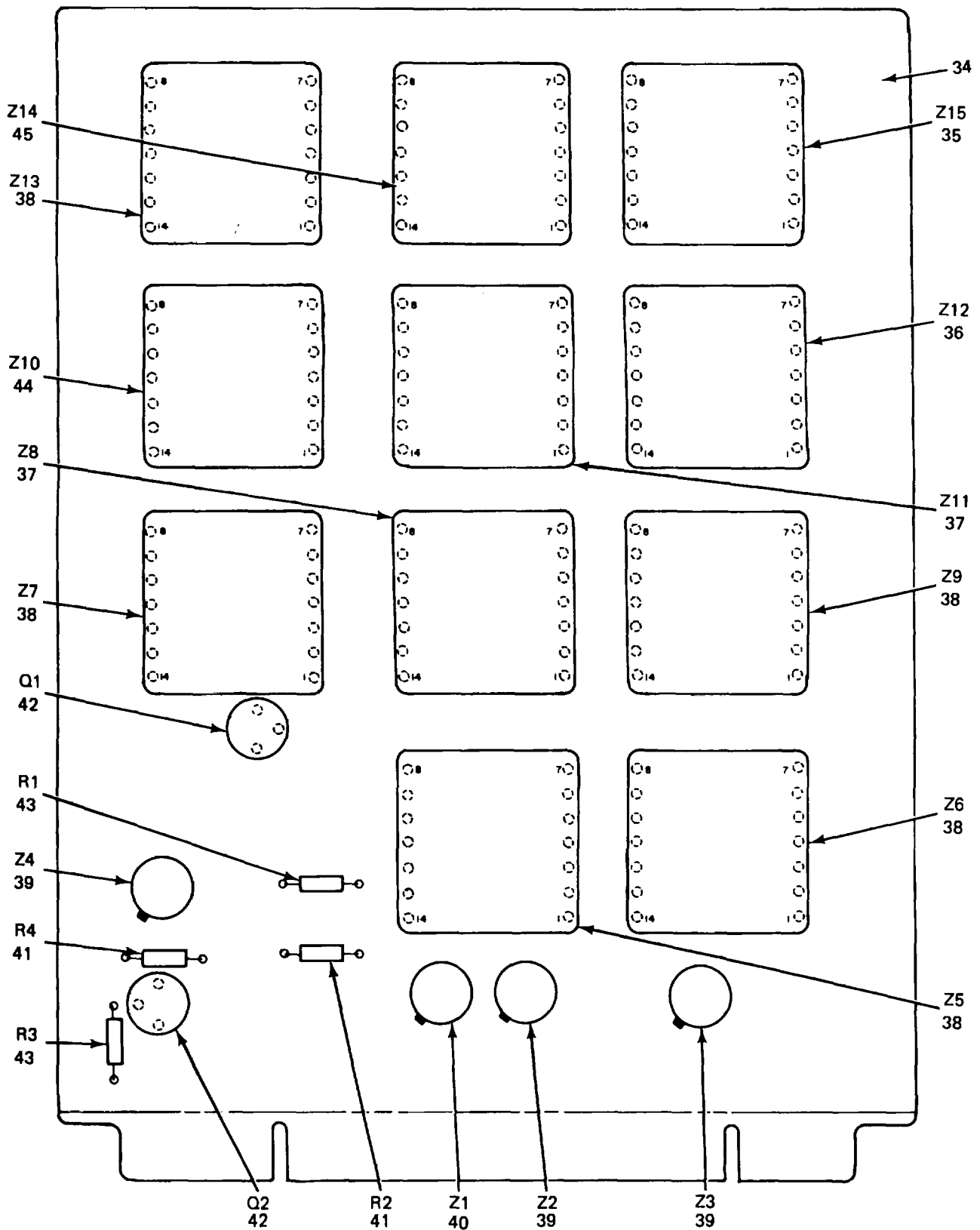

CIRCUIT CARD NO. A65219-001

NOTE: PREFIX ALL REFERENCE DESIGNATIONS WITH A1A1 OR A1A2

EL0QM014

Figure 8. Circuit Card Assembly A1A1 (Sheet 4 of 4).

SECTION II

TM 11-7440-222-40P/NAVELEX 0967-LP-324-0480/TO 31W4-2G-84

(1) ILLUSTRATION		(2)	(3)	(4)	(5)	(6)	(7)	(8)
(a) FIG NO.	(b) ITEM NO.	SMR CODE	NATIONAL STOCK NUMBER	PART NUMBER	FSCM	DESCRIPTION	U/M	QTY INC IN UNIT
						USABLE ON CODE		
8	1	PADZZ	5910-00-060-1187	CM05SF161J03	81349	GROUP 0108 CIRCUIT CARD ASSEMBLY A1A1 CAPACITOR USED ON CIRCUIT CARD		
8	2	PADZZ	5961-00-814-0768	JAN1N3064	81349	ASSY NO.A65201-001.....	EA	2
8	3	PADZZ	5961-00-050-7499	JAN2N2219	81349	SEMICONDUCTOR DEVIC USED ON CIRCUIT CARD ASSY NO.A65201-001.....	EA	25
8	4	PADZZ	5961-00-749-1440	JAN2N2905A	81349	TRANSISTOR USED ON CIRCUIT CARD ASSY NO.A65201-001.	EA	45
8	5	PADZZ	5905-00-681-9969	RC07GF332J	81349	TRANSISTOR USED ON CIRCUIT CARD ASSY NO.A65201-001.	EA	4
8	6	PADZZ	5905-00-686-9997	RC07GF682J	81349	RESISTOR, FIXED, COMP USED ON CIRCUIT CARD ASSY NO.A65201-001.....	EA	2
8	7	PADZZ	5905-00-800-0179	RC07GF563J	81349	RESISTOR, FIXED, COMP USED ON CIRCUIT CARD ASSY NO.A65201-001.....	EA	2
8	8	PADZZ	5905-00-807-4954	RC07GF751J	81349	RESISTOR, FIXED, COMP USED ON CIRCUIT CARD ASSY NO.A65201-001.....	EA	13
8	9	PADZZ	5905-00-682-4097	RC076GF302J	81349	RESISTOR, FIXED, COMP USED ON CIRCUIT CARD ASSY NO.A65201-001.....	EA	2
8	10	PADZZ	5905-00-801-6998	RC07GF621J	81349	RESISTOR, FIXED, COMP USED ON CIRCUIT CARD ASSY NO.A65201-001.....	EA	13
8	11	PADZZ	5905-00-683-2238	RC07GF103J	81349	RESISTOR, FIXED, COMP USED ON CIRCUIT CARD ASSY NO.A65201-001.....	EA	2
8	12	PADZZ	5905-00-195-5571	RC20GF680J	81349	RESISTOR, FIXED, COMP USED ON CIRCUIT CARD ASSY NO.A65201-001.....	EA	24
8	13	PADZZ	5905-00-691-0195	RC07GF562J	81349	RESISTOR, FIXED, COMP USED ON CIRCUIT CARD ASSY NO.A65201-001.....	EA	4
8	14	PADZZ	5905-00-686-3798	RC07GF272J	81349	RESISTOR, FIXED, COMP USED ON CIRCUIT CARD ASSY NO.A65201-001.....	EA	2
8	15	PADZZ	5905-00-681-6462	RC07GF102J	81349	RESISTOR, FIXED, COMP USED ON CIRCUIT CARD ASSY NO.A65201-001.....	EA	4
8	16	PADZZ	5905-00-682-4101	RC07GF752J	81349	RESISTOR, FIXED, COMP USED ON CIRCUIT CARD ASSY NO.A65201-001.....	EA	6
8	17	PADZZ	590-00-686-3369	RC07GF331J	81349	RESISTOR, FIXED, COMP USED ON CIRCUIT CARD ASSY NO.A65201-001.....	EA	4
8	18	PADZZ	5905-00-801-6444	RC07GF911J	81349	RESISTOR, FIXED, COMP USED ON CIRCUIT CARD ASSY NO.A65201-001.....	EA	2
8	19	PADZZ	5905-00-682-4109	RC07GF561J	81349	RESISTOR, FIXED, COMP USED ON CIRCUIT CARD ASSY NO.A65201-001.....	EA	2
8	20	PADZZ	5905-00-687-0000	RC07GF183J	81349	RESISTOR, FIXED, COMP USED ON CIRCUIT CARD ASSY NO.A65201-001.....	EA	1
8	21	PADZZ	5905-00-683-2236	RC07GF391J	81349	RESISTOR, FIXED, COMP USED ON CIRCUIT CARD ASSY NO.A65201-001.....	EA	2
8	22	PADZZ	5905-00-051-8012	RN60D7321F	81349	RESISTOR, FIXED, FILM USED ON CIRCUIT CARD ASSY NO.A65201-001.....	EA	2
8	23	PADZZ	5905-00-683-2246	RC07GF473J	81349	RESISTOR, FIXED, COMP USED ON CIRCUIT CARD ASSY NO.A65201-001.....	EA	11
8	24	PADZZ	5905-00-831-6134	RC07GF822J	81349	RESISTOR, FIXED, COMP USED ON CIRCUIT CARD ASSY NO.A65201-001.....	EA	22
8	25	PADZZL	5905-00-727-8001	RC07GF681J	81349	RESISTOR USED ON CIRCUIT CARD ASSY NO.A65201-001.....	EA	11
8	26	PADZZ	5905-00-686-9998	RC07GF472J	81349	RESISTOR, FIXED, COMP USED ON CIRCUIT CARD ASSY NO.A65201-001.....	EA	11
8	27	PADZZ	5905-00-279-2627	RC42GF750J	81349	RESISTOR, FIXED, COMP USED ON CIRCUIT CARD ASSY NO.A65201-001.....	EA	2
8	28	PADZZ	5961-00-995-2310	JAN1N752A	81349	RESISTOR, FIXED, COMP USED ON CIRCUIT CARD ASSY NO.A65201-001.....	EA	2
8	29	PAOZZ	5961-00-068-0687	JAN1N3828A	81349	SEMICONDUCTOR DEVIC USED ON CIRCUIT CARD ASSY NO.A65201-001.....	EA	2
8	30	PADZZ	5962-00-791-0994	C7580K	183241	SEMICONDUCTOR DEVIC USED ON CIRCUIT CARD ASSY NO.A65201-001.....	EA	2
8	31	PADZZ	5962-00-791-1082	C7090K	18324	MICROCIRCUIT, DIGITA USED ON CCUT CARD ASSY NO.A65201-D001.....	EA	3
8	32	XDOZZ		A65202-001	58189	MICROCIRCUIT, DIGITA USED ON CIRCUIT CARD ASSY NO.A65201-001.....	EA	1
8	33	PADZZ	5999-00-946-0094	10079	07047	PRINTED CIRCUIT BD USED ON CIRCUIT CARD ASSY NO.A65201-001.....	EA	1
8	34	XDDZZ		A65220-001	58189	MOUNTING PAD ELECTR USED ON CIRCUIT CARD ASSY NO.A65201-001.....	EA	153
8	35	PAOZZ	7040-00-134-3725	T00023-002	12436	PRINTED CIRCUIT BD USED ON CIRCUIT CARD NO.A65219-001.....	EA	1
8	36	PAOZZ	7040-00-134-3717	T00024-002	12436	ELECTRONIC COMPONEN USED ON CIRCUIT CARD NO.A6529-001.....	EA	1
8	37	PADZZ	7040-00-134-3713	T00122-002	12436	ELECTRONIC COMPONEN USED ON CIRCUIT CARD NO.A65219-001.....	EA	1
8	38	PADZZ	7040-00-134-3718	T00024-001	12436	ELECTRONIC COMPONEN USED ON CIRCUIT CARD NO.A65219-001.....	EA	2
8	39	PADZZ	5962-00-791-0994	C7580K	183241	ELECTRONIC COMPONEN USED ON CIRCUIT CARD NO.A65219-001.....	EA	5
						MICROCIRCUIT, DIGITA USED ON CIRCUIT CARD NO.A65219-001.....	EA	3

SECTION II

TM 11-7440-222-40P/NAVELEX 0967-LP-324-0480/TO 31W4-2G-84

(1) ILLUSTRATION		(2)	(3)	(4)	(5)	(6) DESCRIPTION	(7)	(8)
(a) FIG NO.	(b) ITEM NO.	SMR CODE	NATIONAL STOCK NUMBER	PART NUMBER	FSCM	USABLE ON CODE	U/M	QTY INC IN UNIT
8	40	PADZZ	5962-00-791-1082	C7090K	18324	MICROCIRCUIT,DIGITA USED ON CIRCUIT CARD NO.A6529-001	EA	1
8	41	PADZZ	5905-00-681-6462	RC07GF102J	81349	RESISTOR,FIXED.COMP USED ON CIRCUIT CARD NO.A65219-001	EA	2
8	42	PADZZ	5961-00-949-1432	JAN2N2219	81349	TRANSISTOR USED ON CIRCUIT CARD NO.A65219-001.....	EA	2
8	43	PADZZ	5905-00-686-9998	RC07GF472J	81349	RESISTOR,FIXED,COMP USED ON CIRCUIT CARD NO.A65219-001	EA	2
8	44	PADZZ	7040-00-134-3723	T00121-004	12436	ELECTRONIC CONPONEN USED ON CIRCUIT CARD NO.A65219-001	EA	1
8	45	PADZZ	7040-00-134-3724	T00023-001	12436	ELECTRONIC CORPONEN USED ON CIRCUIT CARD NO.A65219-001	EA	1
26(27 blank)								

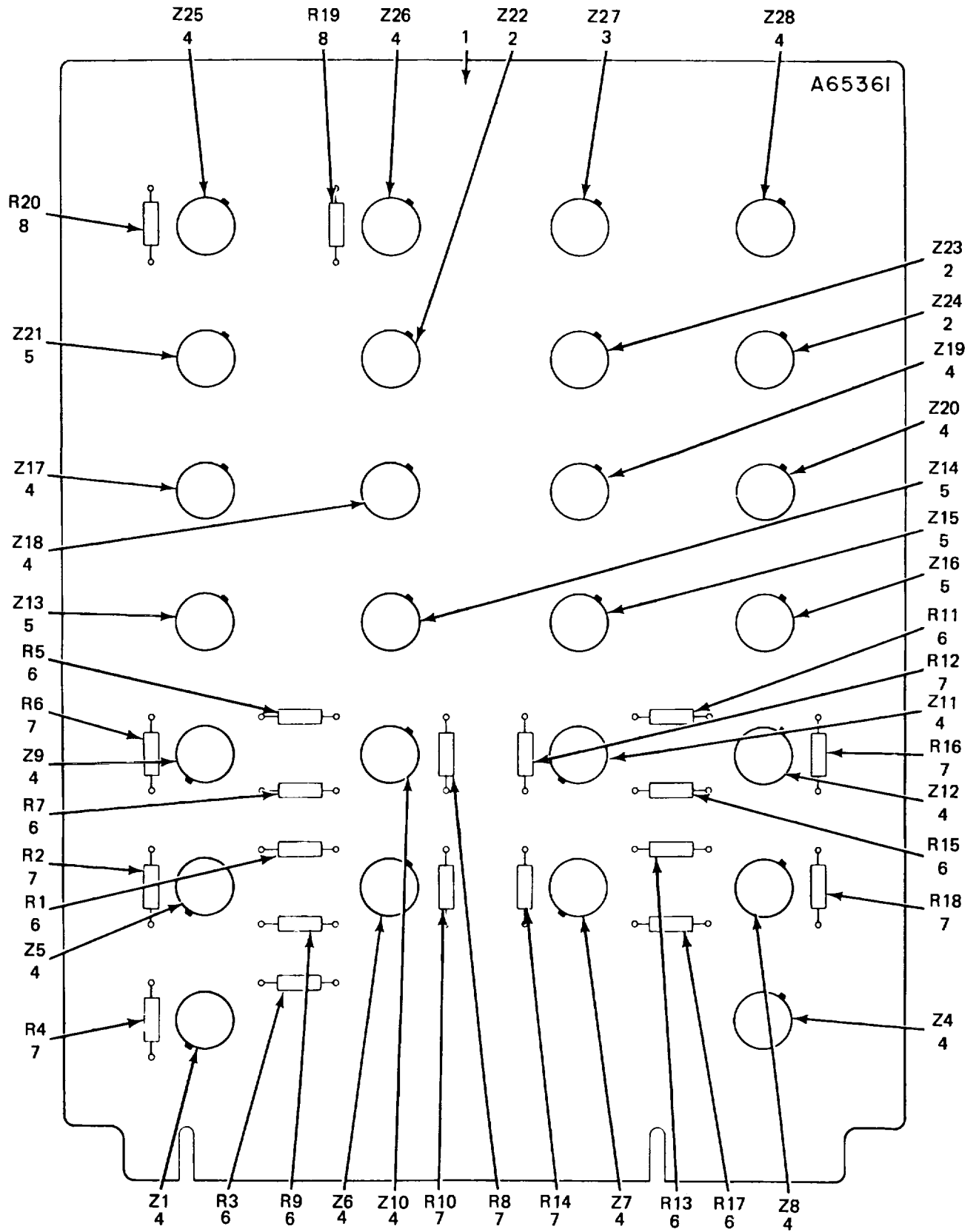

ELOQM015

Figure 9. Circuit Card Assembly A1A5.

SECTION II

TM 11-7440-222-40P/NAVELEX 0967-LP-324-0480/TO 31W4-2G-84

(1) ILLUSTRATION		(2)	(3)	(4)	(5)	(6) DESCRIPTION	(7)	(8)
(a) FIG NO.	(b) ITEM NO.	SMR CODE	NATIONAL STOCK NUMBER	PART NUMBER	FSCM	USABLE ON CODE	U/M	QTY INC IN UNIT
						GROUP 0110 CIRCUIT CARD ASSEMBLY A1A5		
9	1	XDDZZ		A65362-00L	58189	PRINTED CIRCUIT	EA	1
9	2	PADZZ	5962-00-791-1048	C7577K	18324	INTEGRATED CIRCUIT	EA	3
9	3	PADZZ	5962-00-791-1120	C7579	18324	INTEGRATED CIRCUIT	EA	1
9	4	PADZZ	5962-00-791-1082	C7090K	18324	INTEGRATED CIRCUIT	EA	17
9	5	PADZZ	5962-00-167-7897	C7088K	18324	INTEGRATED CIRCUIT	EA	5
9	6	PADZZ	5905-00-683-7723	RC07GF152J	81349	RESISTOR.FIXED,COMP	EA	9
9	7	PADZZ	5905-00-801-6444	RC07GF911J	81349	RESISTOR.FIXED,COMP	EA	9
9	8	PADZZ	5905-00-723-5251	RC07GF222J	81349	RESISTOR.FIXED,COMP	EA	2
					29			

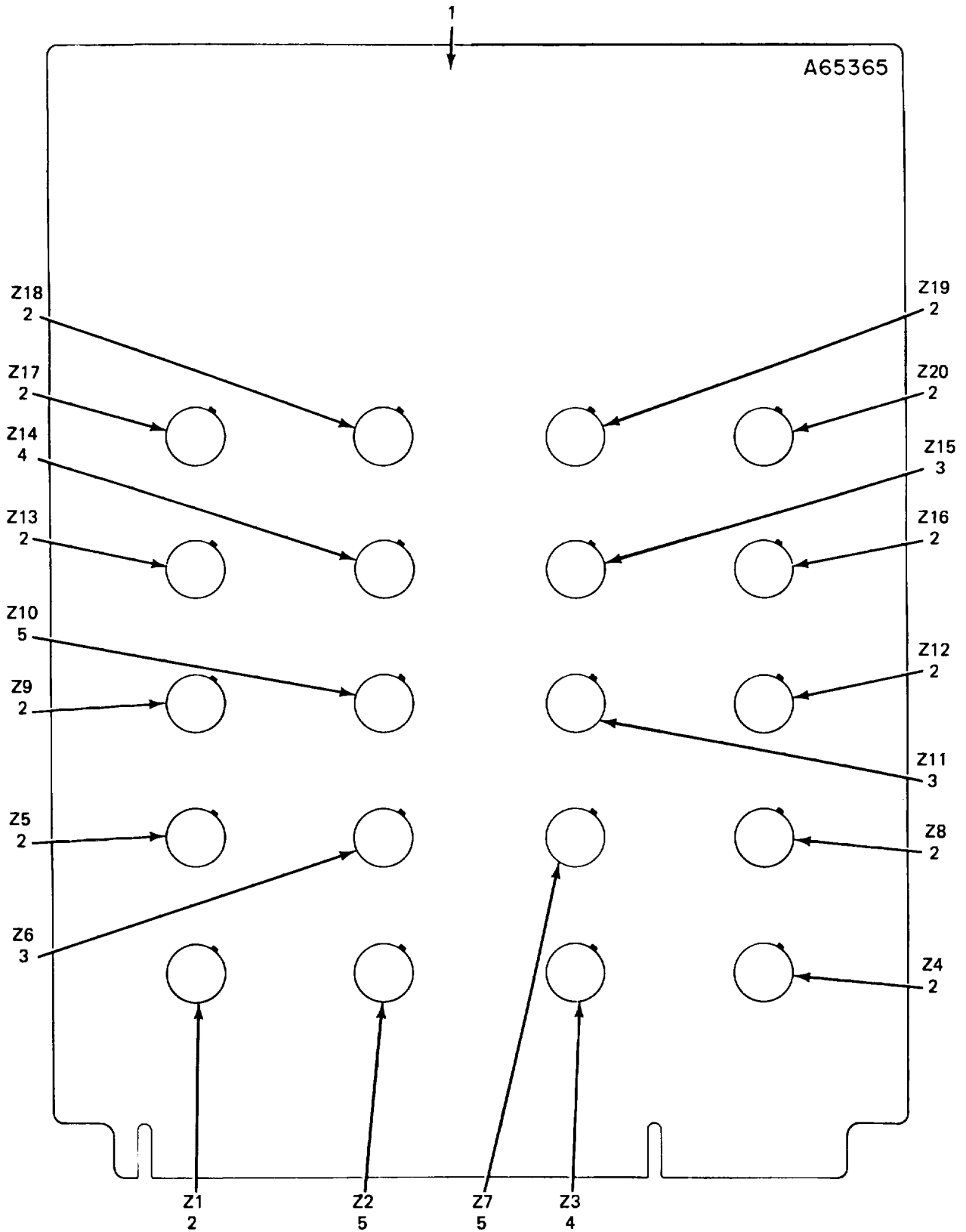

NOTE: PREFIX ALL REFERENCE DESIGNATIONS WITH A1A6

EL0QM016

Figure 10. Circuit Card Assembly A1A6.

SECTION II

TM 11-7440-222-40P/NAVELEX 0967-LP-324-0480/TO 31W4-2G-84

(1) ILLUSTRATION		(2)	(3)	(4)	(5)	(6) DESCRIPTION	(7)	(8)
(a) FIG NO.	(b) ITEM NO.	SMR CODE	NATIONAL STOCK NUMBER	PART NUMBER	FSCM	USABLE ON CODE	U/M	QTY INC IN UNIT
						GROUP 0111 CIRCUIT CARD ASSEMBLY A1A6		
10	1	XDDZZ		A65366-001	58189	PRINTED CIRCUIT BD	EA	1
10	2	PADZZ	5962-00-791-1393	C7091K	18324	MICROCIRCUIT,DIGITA,.....	EA	12
10	3	PADZZ	5962-00-791-1082	C7090K	18324	MICROCIRCUIT,DIGITA,.....	EA	3
10	4	PADZZ	5962-00-167-7897	C7088K	18324	INTEGRATED CIRCUIT	EA	2
10	5	PADZZ	5962-00-791-0994	C7580K	18324	INTEGRATED CIRCUIT	EA	3
					31			

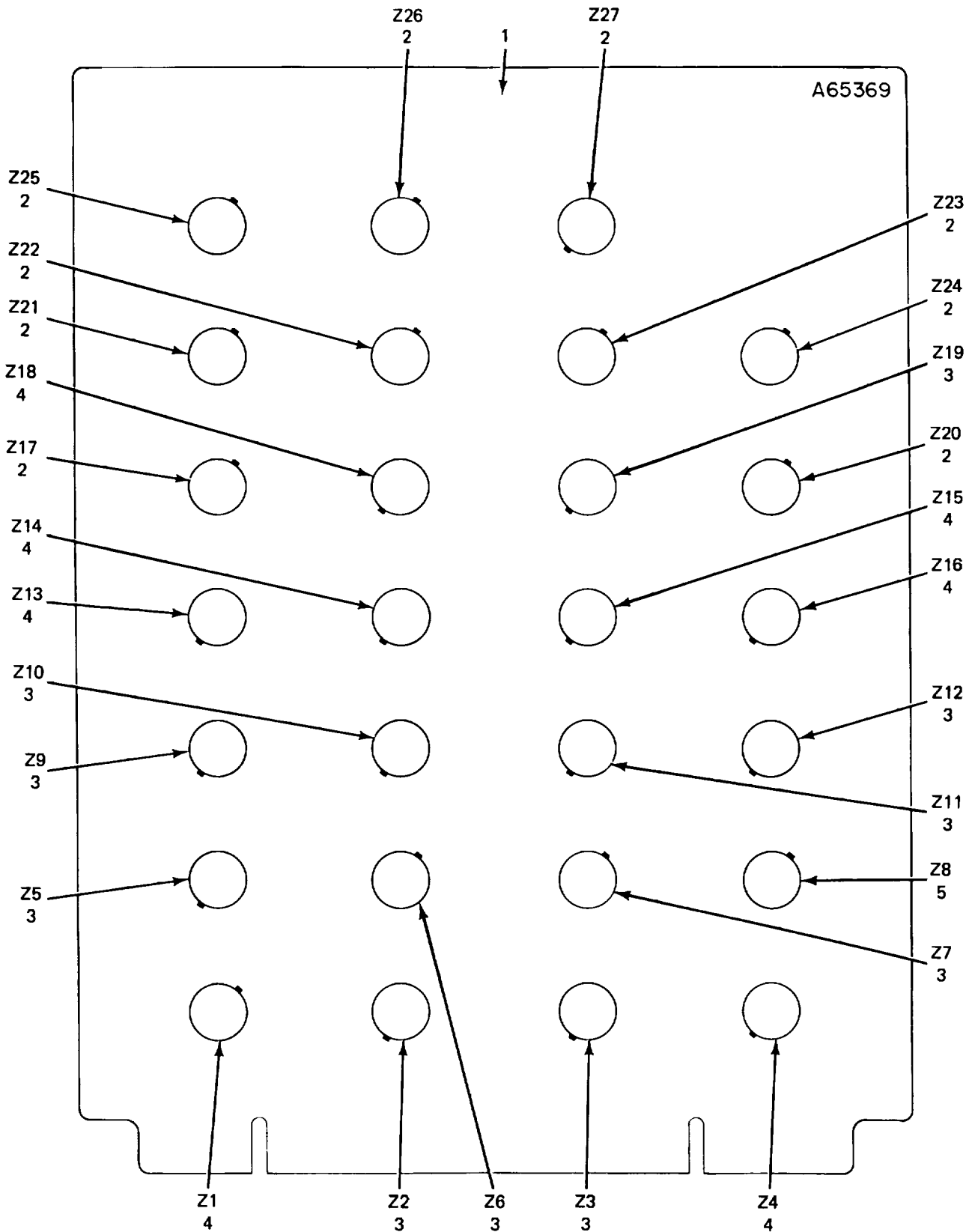

NOTE: PREFIX ALL REFERENCE DESIGNATIONS WITH A1A7

ELOQM017

Figure 11. Circuit Card Assembly A1A7.

SECTION II

TM 11-7440-222-40P/NAVELEX 0967-LP-324-0480/TO 31W4-2G-84

(1) ILLUSTRATION		(2)	(3)	(4)	(5)	(6) DESCRIPTION	(7)	(8)
(a) FIG NO.	(b) ITEM NO.	SMR CODE	NATIONAL STOCK NUMBER	PART NUMBER	FSCM	USABLE ON CODE	U/M	QTY INC IN UNIT
						GROUP 0112 CIRCUIT CARD ASSEMBLY A1A7		
11	1	XDDZZ		A65370-001	58189	PRINTED CIRCUIT BD	EA	1
11	2	PADZZ	5962-00-791-1393	C7091K	18324	INTEGRATED CIRCUIT	EA	9
11	3	PADZZ	5962-00-791-1082	C7090K	18324	INTEGRATED CIRCUIT	EA	10
11	4	PADZZ	5962-00-791-0994	C7580K	18324	INTEGRATED CIRCUIT	EA	7
11	5	PADZZ	5962-00-167-7897	C7088K	18324	INTEGRATED CIRCUIT	EA	1
					33			

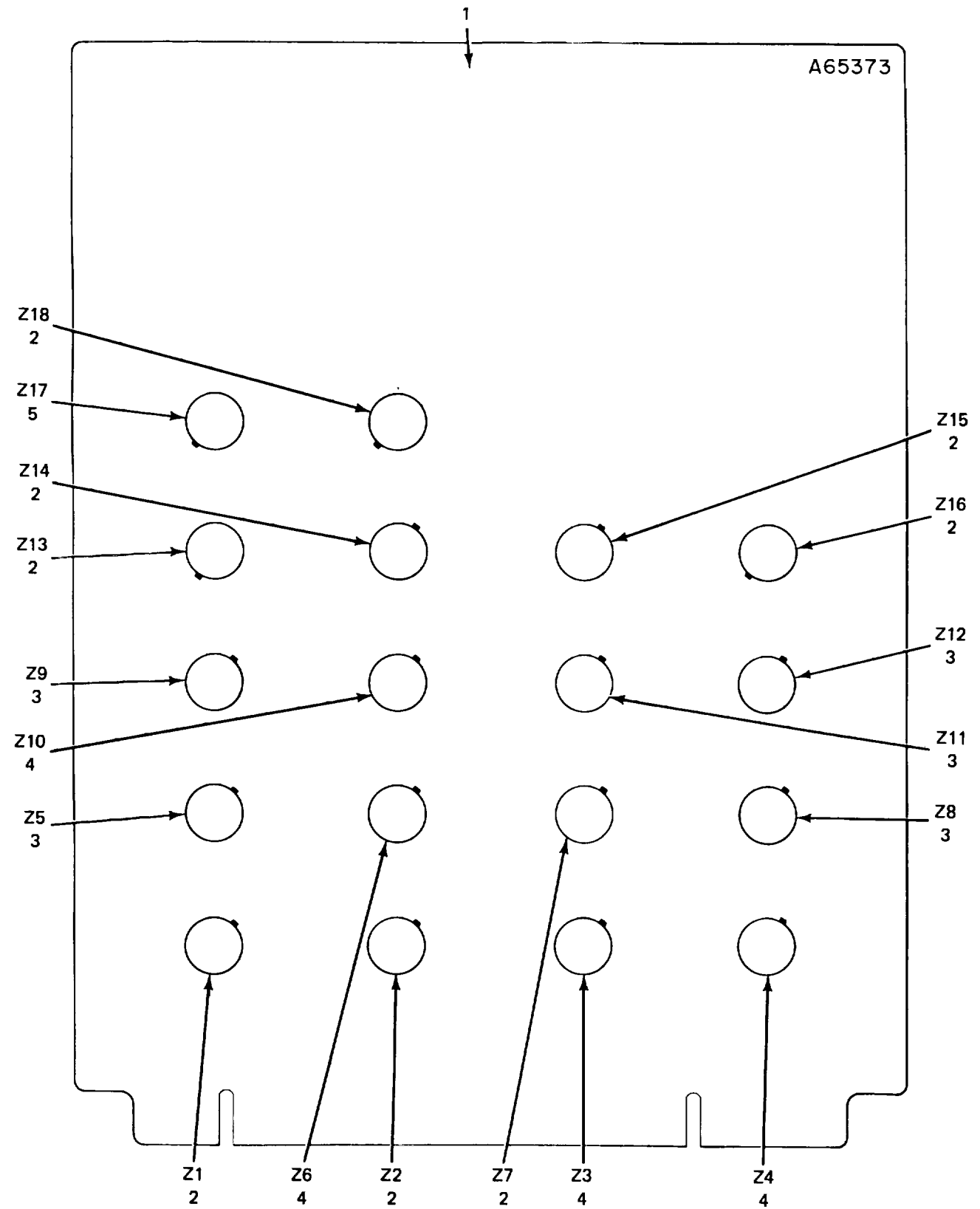
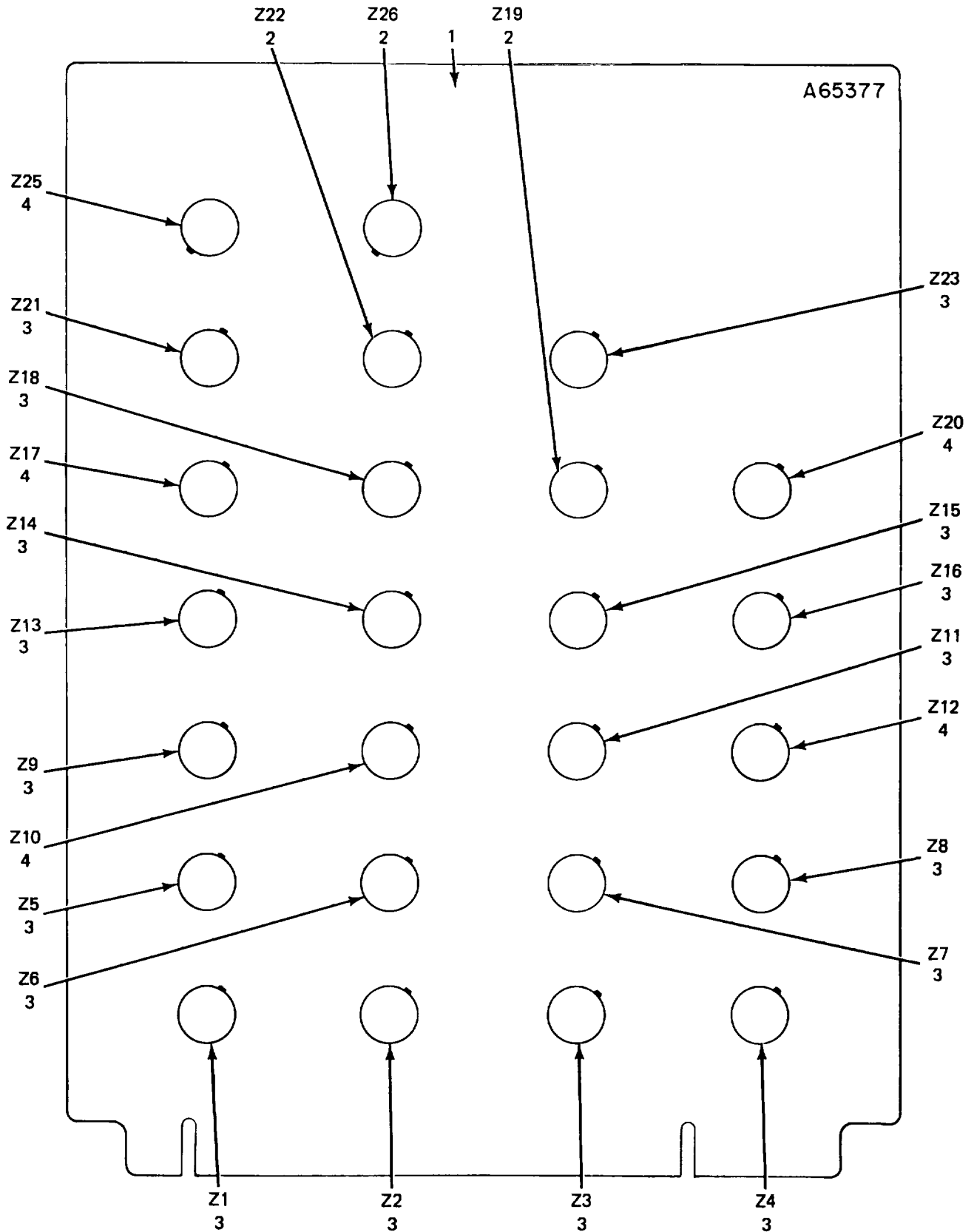

Figure 12. Circuit Card Assembly A1A19.

SECTION II

TM 11-7440-222-40P/NAVELEX 0967-LP-324-0480/TO 31W4-2G-84

(1) ILLUSTRATION		(2)	(3)	(4)	(5)	(6) DESCRIPTION	(7)	(8)
(a) FIG NO.	(b) ITEM NO.	SMR CODE	NATIONAL STOCK NUMBER	PART NUMBER	FSCM	USABLE ON CODE	U/M	QTY INC IN UNIT
						GROUP 0113 CIRCUIT CARD ASSEMBLY A1A19		
12	1	XDDZZ		A65374-001	58119	PRINTED CIRCUIT BD	EA	1
12	2	PADZZ	5962-00-791-0994	C7580K	18324	INTEGRATED CIRCUIT	EA	8
12	3	PADZZ	5962-00-791-1082	C7090K	18324	INTEGRATED CIRCUIT	EA	5
12	4	PADZZ	5962-00-791-1120	CT579K	18324	INTEGRATED CIRCUIT	EA	4
12	5	PADZZ	5962-00-167-7897	CT88K	18324	INTEGRATED CIRCUIT	EA	1
					35			



NOTE: PREFIX ALL REFERENCE DESIGNATIONS WITH A1A9

EL0QM019

Figure 13. Circuit Card Assembly A1A9.

SECTION II

TM 11-7440-222-40P/NAVELEX 0967-LP-324-0480/TO 31W4-2G-84

(1) ILLUSTRATION		(2)	(3)	(4)	(5)	(6) DESCRIPTION	(7)	(8)
(a) FIG NO.	(b) ITEM NO.	SMR CODE	NATIONAL STOCK NUMBER	PART NUMBER	FSCM	USABLE ON CODE	U/M	QTY INC IN UNIT
						GROUP 0114 CIRCUIT CARD ASSEMBLY A1A9		
13	1	XDDZZ		A65318-001	58189	PRINTED CIRCUIT BD	EA	1
13	2	PADZZ	5962-00-791-0994	C7580K	18324	INTEGRATED CIRCUIT	EA	3
13	3	PADZZ	5962-00-791-1082	C7090K	18324	INTEGRATED CIRCUIT	EA	17
13	4	PADZZ	5962-00-167-7897	C7088K	18324	INTEGRATED CIRCUIT	EA	5
					37			

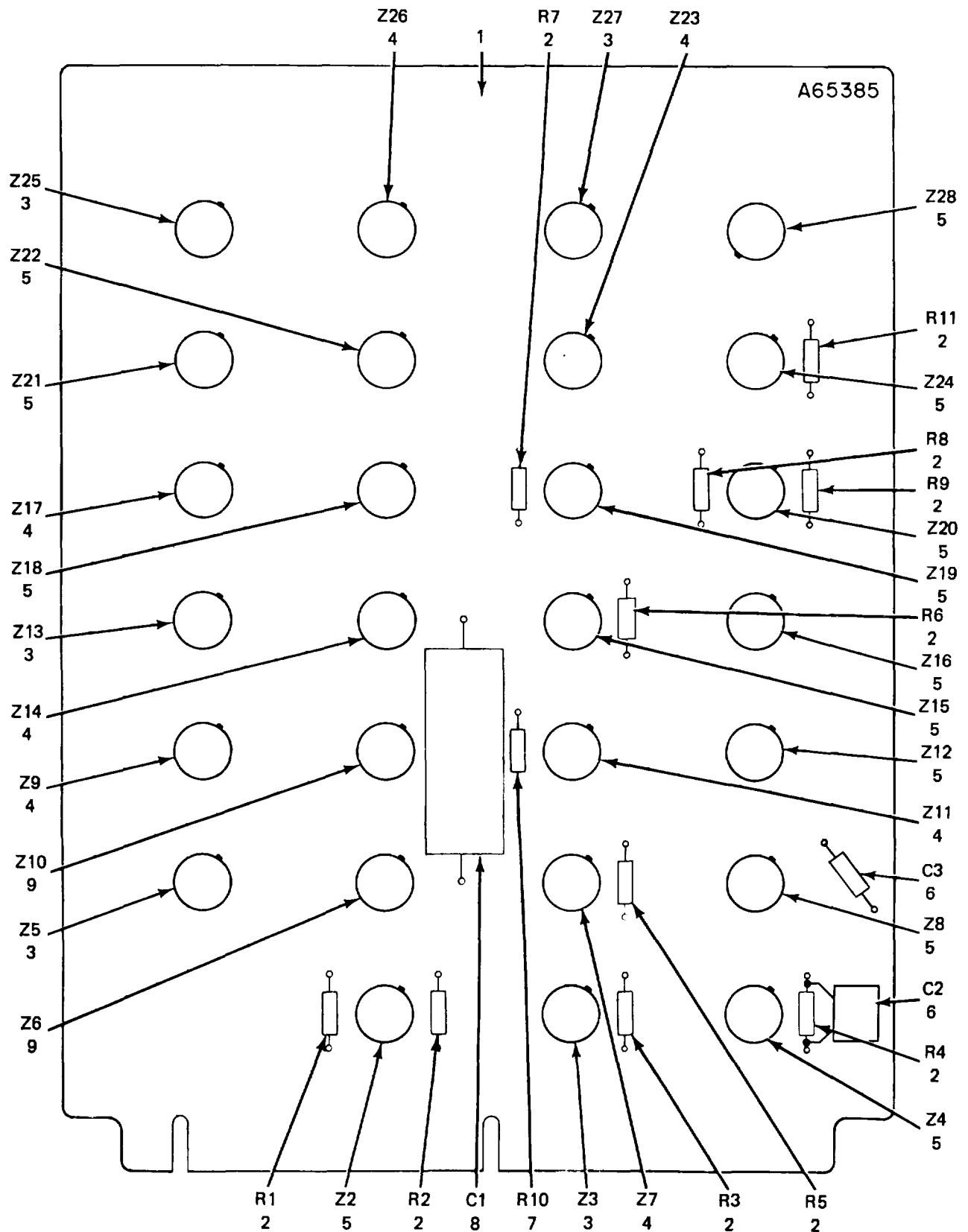
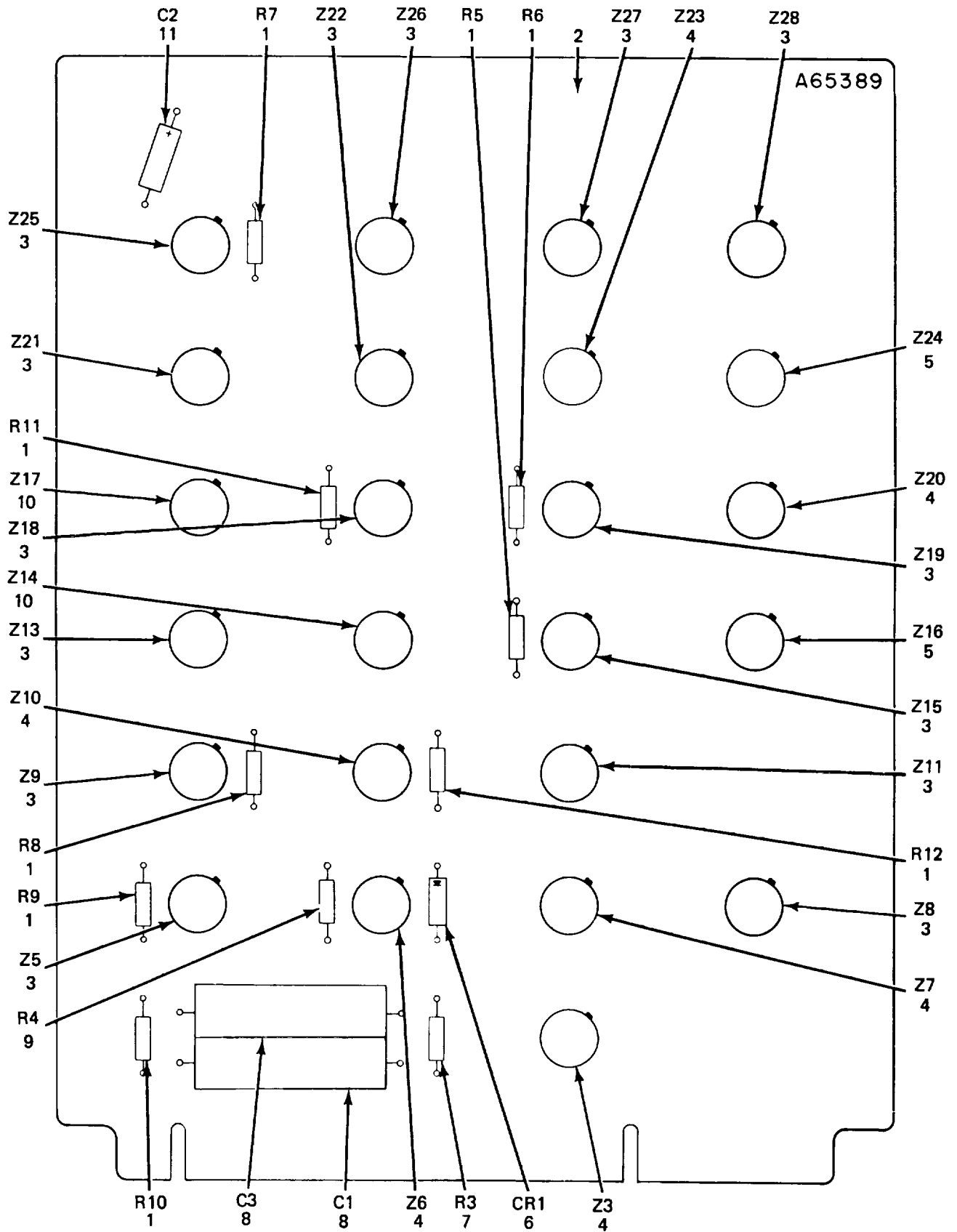

Figure 14. Circuit Card Assembly A1A10.

SECTION II

TM 11-7440-222-40P/NAVELEX 0967-LP-324-0480/TO 31W4-2G-84

(1) ILLUSTRATION		(2)	(3)	(4)	(5)	(6) DESCRIPTION	(7)	(8)
(a) FIG NO.	(b) ITEM NO.	SMR CODE	NATIONAL STOCK NUMBER	PART NUMBER	FSCM	USABLE ON CODE	U/M	QTY INC IN UNIT
						GROUP 0115 CIRCUIT CARD ASSEMBLY A1A10		
14	1	XDDZZ		A65386-001	58189	PRINTED CIRCUIT BD	EA	1
14	2	PADZZ	5905-00-723-5251	RC07GFF222J	81349	RESISTOR, FIXED, COMP	EA	10
14	3	PADZZ	5962-00-167-7897	C7088K	18324	INTEGRATED CIRCUIT	EA	5
14	4	PADZZ	5962-00-791-0994	C7580K	18324	INTEGRATED CIRCUIT	EA	7
14	5	PADZZ	5962-00-T91-1082	C7090K	18324	MICROCIRCUIT, DIGITA	EA	13
14	6	PADZZ	5910-00-113-5499	CK06BX104M	81349	CAPACITOR, FIXED, CER	EA	2
14	7	PADZZ	5905-00-687-0002	RC07GF223J	81349	RESISTOR, FIXED, COMP	EA	1
14	8	PADZZ	5910-00-899-4395	CP09A1KB104K3	81349	CAPACITOR, FIXED, PAP	EA	1
14	9	PADZZ	5962-00-791-1393	C7091K	18324	INTEGRATED CIRCUIT	EA	2
					39			



NOTE: PREFIX ALL REFERENCE DESIGNATIONS WITH A1A11

EL0QM021

Figure 15. Circuit Card Assembly A1A11.

SECTION II

TM 11-7440-222-40P/NAVELEX 0967-LP-324-0480/TO 31W4-2G-84

(1) ILLUSTRATION		(2)	(3)	(4)	(5)	(6) DESCRIPTION	(7)	(8)
(a) FIG NO.	(b) ITEM NO.	SMR CODE	NATIONAL STOCK NUMBER	PART NUMBER	FSCM	USABLE ON CODE	U/M	QTY INC IN UNIT
						GROUP 0116 CIRCUIT CARD ASSEMBLY A1A11		
15	1	PADZZ	5905-00-723-5251	RC07GF222J	81349	RESISTOR, FIXED, COMP	EA	8
15	2	XDDZZ		A65390-001	58189	PRINTED CIRCUIT BD	EA	1
15	3	PADZZ	5962-00-791-1082	C7090K	18324	INTEGRATED CIRCUIT	EA	14
15	4	PADZZ	5962-00-791-0994	C7580K	18324	INTEGRATED CIRCUIT	EA	6
15	5	PADZZ	5962-00-167-7897	C7088K	18324	INTEGRATED CIRCUIT	EA	2
15	6	PADZZ	5961-00-814-0768	JAN1N3064	81349	SEMICONDUCTOR DEVIC.....	EA	1
15	7	PADZZ	5905-00-682-4098	RC07GF392J	81349	RESISTOR, FIXED, COMP	EA	1
15	8	PAODZZ	5910-00-835-2175	CP09A1KB103K3	81349	CAPACITOR, FIXED, PAP.....	EA	2
15	9	PADZZ	5905-00-116-2394	RC07GF511J	81349	RESISTOR, FIXED, COMP.....	EA	1
15	10	PADZZ	5962-00-791-1393	C7091K	18324	INTEGRATED CIRCUIT	EA	2
15	11	PADZZ	5910-00-455-4304	CS13BF334M	81349	CAPACITOR, FIXED, ELE	EA	1
					41			

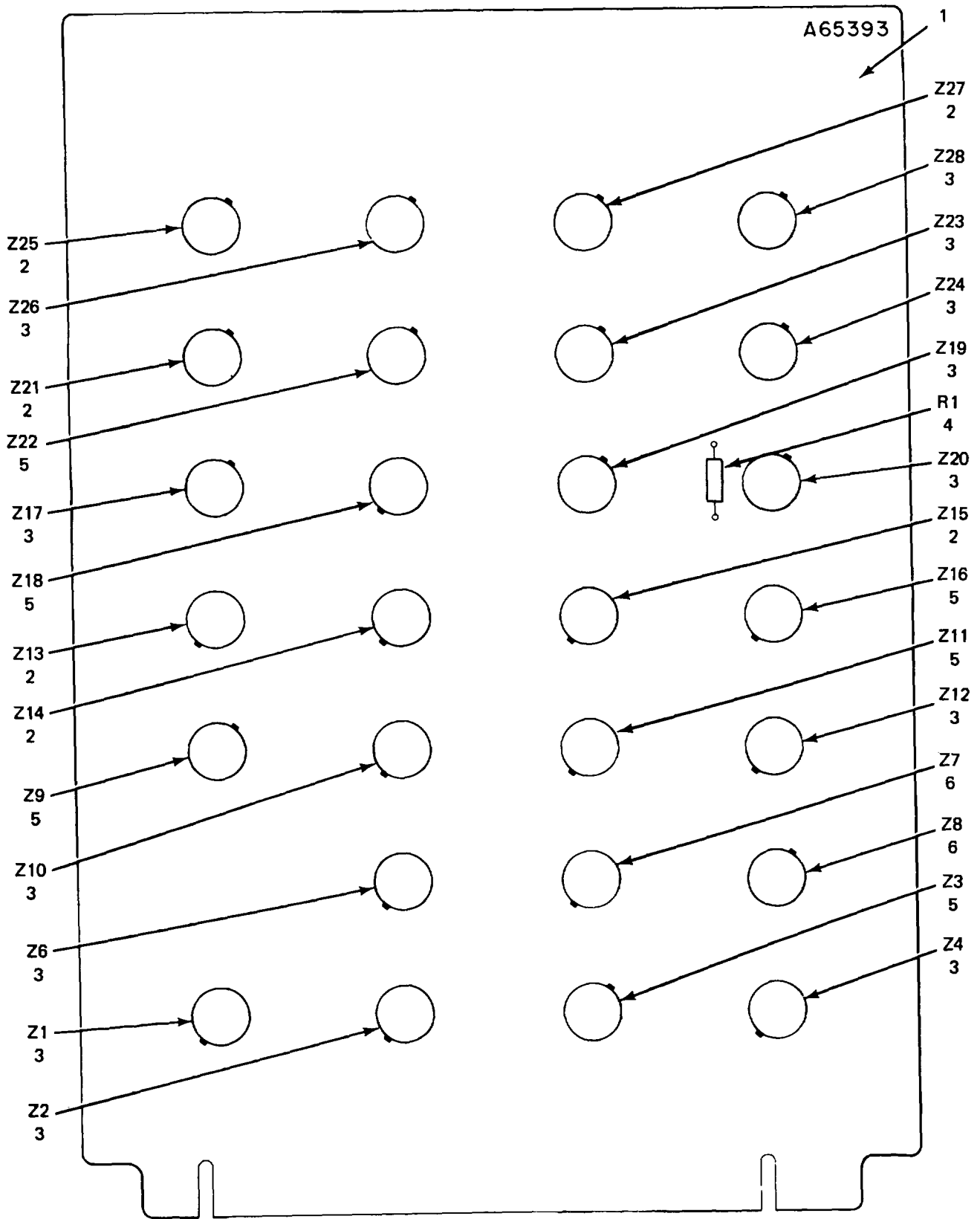

NOTE: PREFIX ALL REFERENCE DESIGNATIONS WITH A1A4

EL0QM022

Figure 16. Circuit Card Assembly A1A4.

SECTION II

TM 11-7440-222-40P/NAVELEX 0967-LP-324-0480/TO 31W4-2G-84

(1) ILLUSTRATION		(2)	(3)	(4)	(5)	(6) DESCRIPTION	(7)	(8)
(a) FIG NO.	(b) ITEM NO.	SMR CODE	NATIONAL STOCK NUMBER	PART NUMBER	FSCM	USABLE ON CODE	U/M	QTY INC IN UNIT
						GROUP 0117 CIRCUIT CARD ASSEMBLY A1A4		
16	1	XDDZZ		A65394-001	58189	PRINTED CIRCUIT BD	EA	1
16	2	PADZZ	5962-00-791-1393	C7091K	18324	INTEGRATED CIRCUIT	EA	6
16	3	PADZZ	5962-00-791-1082	C7090K	18324	INTEGRATED CIRCUIT	EA	13
16	4	PADZZ	59-00-723-5251	RC7GF222J	8139	RESISTOR, FIXED, COMP	EA	1
16	5	PADZZ	5962-00-791-0994	C7580K	18324	INTEGRATED CIRCUIT	EA	6
16	6	PADZZ	5962-00-167-T97	C7088K	18324	MICROCIRCUIT, DIGITA	EA	2
					43			

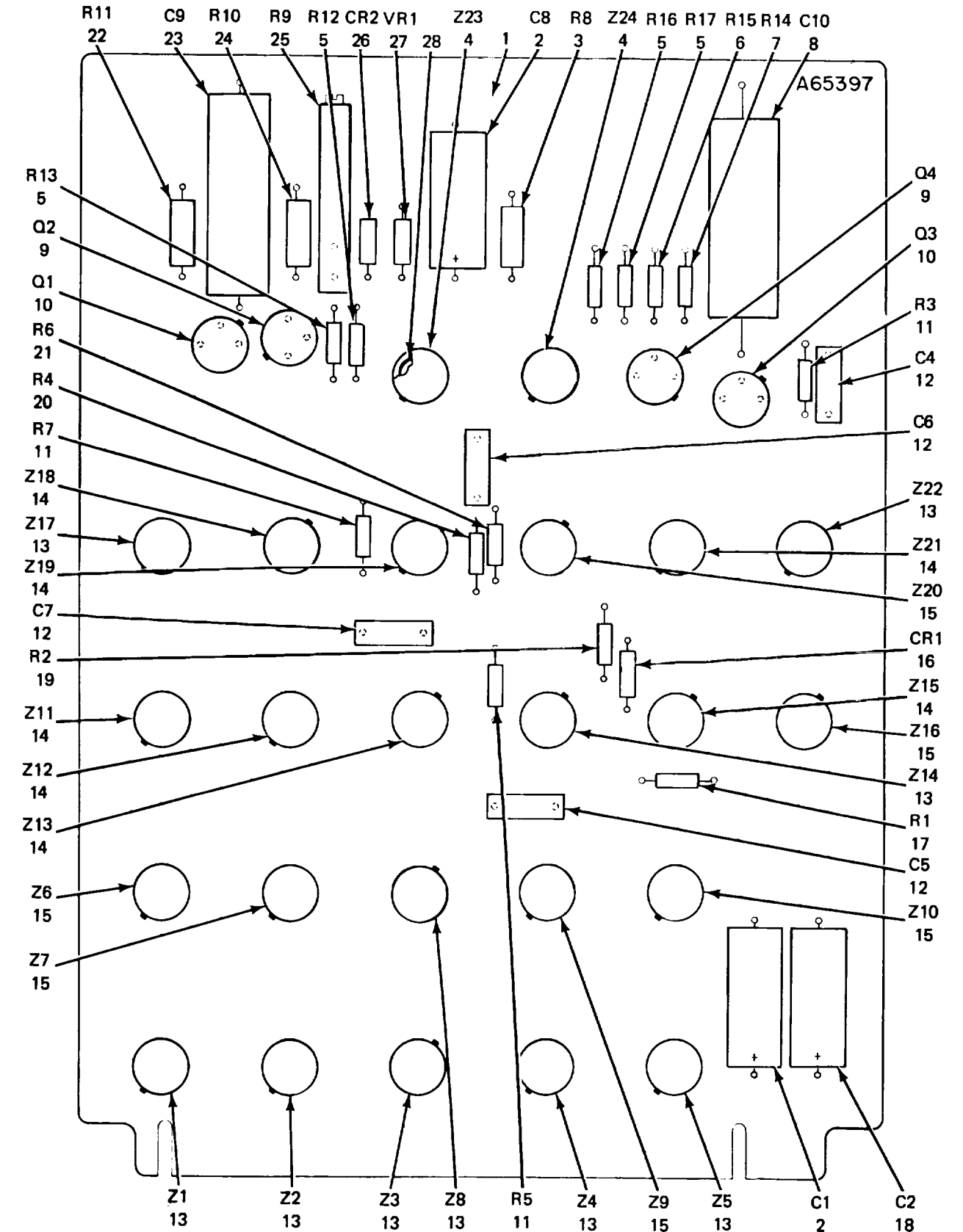

NOTE: PREFIX ALL REFERENCE DESIGNATIONS WITH A1A3

EL0QM023

Figure 17. Circuit Card Assembly A1A3.

SECTION II

TM 11-7440-222-40P/NAVELEX 0967-LP-324-0480/TO 31W4-2G-84

(1) ILLUSTRATION		(2)	(3)	(4)	(5)	(6) DESCRIPTION	(7)	(8)
(a) FIG NO.	(b) ITEM NO.	SMR CODE	NATIONAL STOCK NUMBER	PART NUMBER	FSCM	USABLE ON CODE	U/M	QTY INC IN UNIT
						GROUP 0118 CIRCUIT CARD ASSEMBLY A1A3		
17	1	XDDZZ		A65398-001	58189	PRINTED CIRCUIT BD	EA	1
17	2	PADZZ	5910-00-236-8745	CS13BEO17M	81349	CAPACITOR, FIXED, ELE	EA	2
17	3	PADZZ	5905-00-252-5434	RC20GF121J	81349	RESISTOR, FIXED, COMP	EA	1
17	4	PADZZ	5962-00-791-1393	C7091K	18324	MICROCIRCUIT, DIGITA	EA	2
17	5	PADZZ	5905-00-681-6462	RC07GF102J	81349	RESISTOR, FIXED, COMP	EA	4
17	6	PADZZ	5905-00-683-2247	RC07GF121J	81349	RESISTOR, FIXED, COMP	EA	1
17	7	PADZZ	5905-00-681-8822	RC07GF274J	81349	RESISTOR, FIXED, COMP	EA	1
17	8	PADZZ	5910-00-823-1024	CP09A1KB154K3	81349	CAPACITOR, FIXED, PAP	EA	1
17	9	PADZZ	5961-00-050-7499	JAN2N2219	81349	TRANSISTOR.....	EA	2
17	10	PADZZ	5961-00-926-2569	JAN2N491A	81349	TRANSISTOR.....	EA	2
17	11	PADZZ	5905-00-723-5251	RC07GF222J	81349	RESISTOR, FIXED, COMP	EA	3
17	12	PADZZ	5910-00-771-9026	4M104	967331	CAPACITOR, FIXED, PLA	EA	4
17	13	PADZZ	5962-00-791-0994	C7580K	18324	INTEGRATED CIRCUIT	EA	9
17	14	PADZZ	5962-00-791-1082	C7090K	18324	INTEGRATED CIRCUIT	EA	7
17	15	PADZZ	5962-00-167-7897	C7088K	18324	INTEGRATED CIRCUIT	EA	6
17	16	PADZZ	5961-00-814-0768	JAN1N3064	81349	SEMICONDUCTOR DEVIC.....	EA	1
17	17	PADZZ	5905-00-682-4098	RC07GF392J	81349	RESISTOR, FIXED, COMP	EA	1
17	18	PADZZ	5910-00-142-6950	CS13BC227M	81349	CAPACITOR, FIXED, ELE	EA	1
17	19	PADZZ	5905-00-116-2394	RC07GF511J	81349	RESISTOR, FIXED, COMP	EA	1
17	20	PADZZ	5905-00-683-7723	RC07GF152J	81349	RESISTOR, FIXED, COMP	EA	1
17	21	PADZZ	5905-00-801-6444	RC07GF911J	81349	RESISTOR, FIXED, COMP	EA	1
17	22	PADZZ	5905-00-969-5851	RN60D1210F	81349	RESISTOR, FIXED, FILM.....	EA	1
17	23	XDDZZ		XL5223A1SC	09454	CAPACITOR, FXD, PLSTC	EA	1
17	24	PADZZ	5905-00-078-7777	RN60D2741F	81349	RESISTOR, FIXED, FILM.....	EA	1
17	25	PADZZ	5905-00-689-6799	RT12C2P502	81349	RESISTOR, VARIABLE, W	EA	1
17	26	PADZZ	5961-00-226-5139	JAN1N3666-2	81349	SEMICONDUCTOR DEVIC.....	EA	1
17	27	PADZZ	5961-00-845-6458	JAN1N756A	81349	SEMICONDUCTOR DEVIC.....	EA	1
17	28	PADZZ	5999-00-946-0947	10079	07047	MOUNTING PAD, ELECTR.....	EA	2
					45			

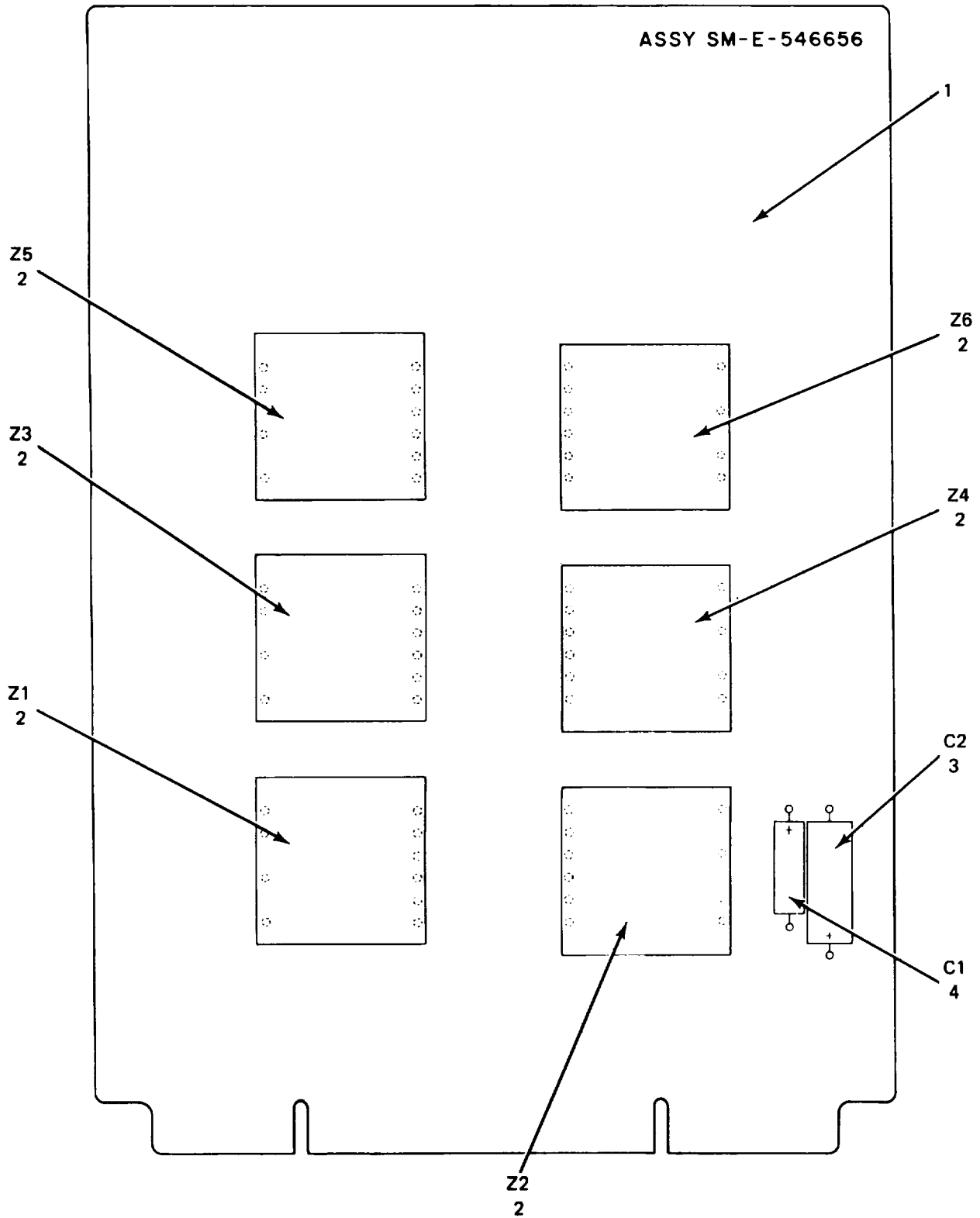

NOTE: PREFIX ALL REFERENCE DESIGNATIONS WITH A1A20

EL0QM024

Figure 18. Circuit Card Assembly A1A20.

SECTION II

TM 11-7440-222-40P/NAVELEX 0967-LP-324-0480/TO 31W4-2G-84

(1) ILLUSTRATION		(2)	(3)	(4)	(5)	(6) DESCRIPTION	(7)	(8)
(a) FIG NO.	(b) ITEM NO.	SMR CODE	NATIONAL STOCK NUMBER	PART NUMBER	FSCM	USABLE ON CODE	U/M	QTY INC IN UNIT
						GROUP 0119 CIRCUIT CARD ASSEMBLY A1A20		
18	1	XDDZZ		SME546657	80063	PRINTED CIRCUIT BD	EA	1
18	2	PADZZ	5962-00-791-1370	SMC634786	80063	MICROCIRUIT,DIGITA.....	EA	6
18	3	PADZZ	5910-00-899-9129	CS13BD686M	81349	CAPACITOR,FIXED,ELE	EA	1
18	4	PADZZ	5910-00-007-3974	M39003-01-2991	81349	CAPACITOR,ELCTLT	EA	1
					47			

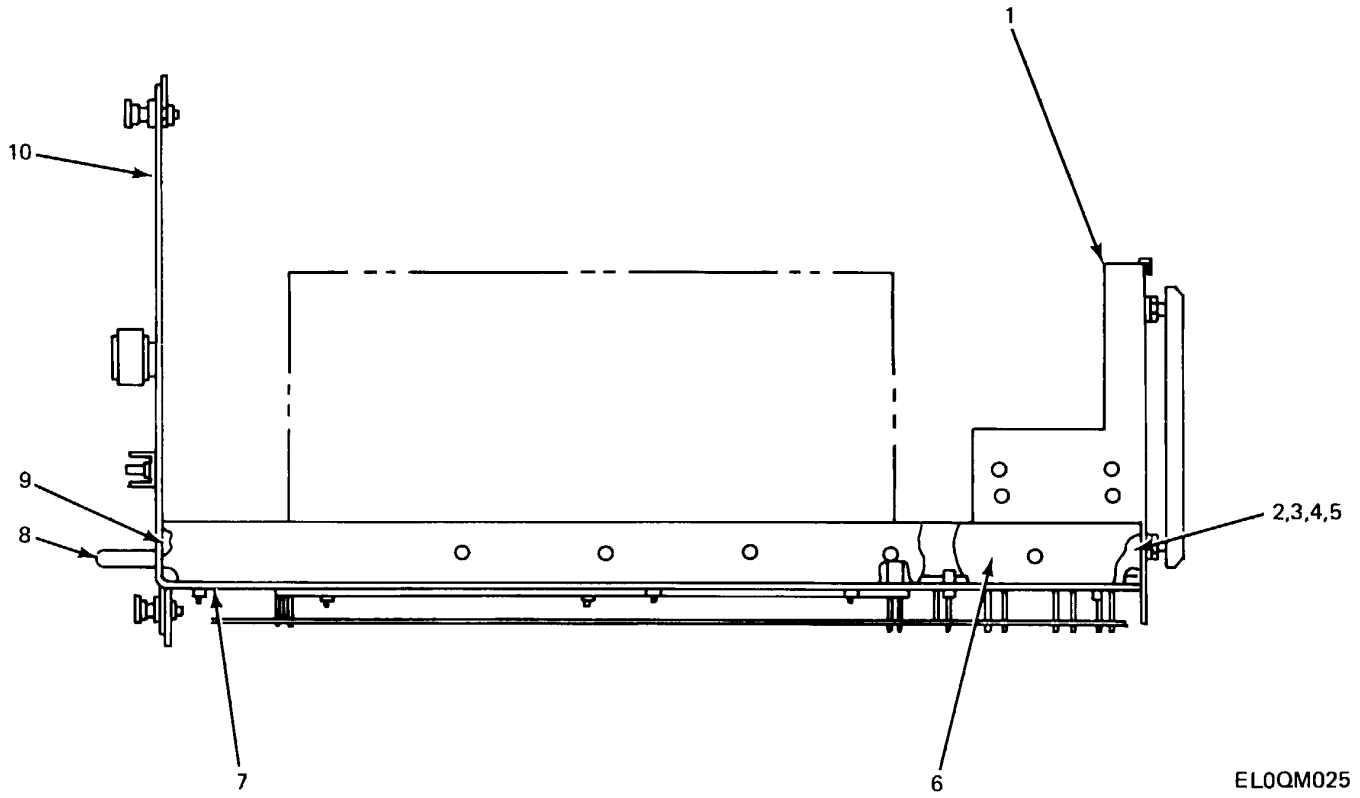

EL0QM025

Figure 19. Logic Chassis.

SECTION II

TM 11-7440-222-40P/NAVELEX 0967-LP-324-0480/TO 31W4-2G-84

(1) ILLUSTRATION		(2)	(3)	(4)	(5)	(6) DESCRIPTION	(7)	(8)
(a) FIG NO.	(b) ITEM NO.	SMR CODE	NATIONAL STOCK NUMBER	PART NUMBER	FSCM	USABLE ON CODE	U/M	QTY INC IN UNIT
						GROUP 0120 LOGIC CHASSIS		
19	1	XDHHH		A64504-004	58189	LOGIC ASSEMBLY	EA	1
19	2	PAHZZ	5305-00-059-3660	MS51958-64	96906	SCREW,MACHINE	EA	4
19	3	PAHZZ	5310-00-933-8120	MS35338-138	96906	WASHER,LOCK	EA	2
19	4	PAHZZ	5310-00-167-0812	AN960C10L	88044	WASHER,FLAT	EA	2
19	5	PAHZZ	5310-00-270-8810	MS35650-104	96906	WASHER	EA	4
19	6	XDHHH		A64504-003	58189	LOGIC ASSEMBLY	EA	1
19	7	XDHZZ		C300S24	06666	SLIDE	EA	2
19	8	PAHZZ	5340-00-060-5386	MS39087-3	96906	HANDLE,BOW	EA	1
19	9	PAHZZ	5305-00-059-3661	MS51958-65	96906	SCREW,MACHINE	EA	2
19	10	XDHHH		A64504-005	58189	FRONT PANEL ASSY	EA	1
					49			

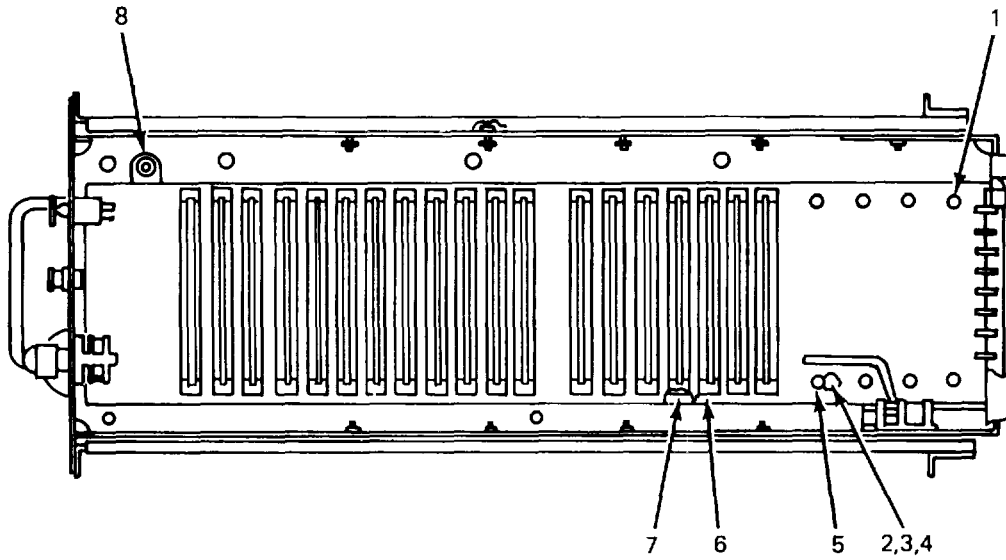

TOP VIEW

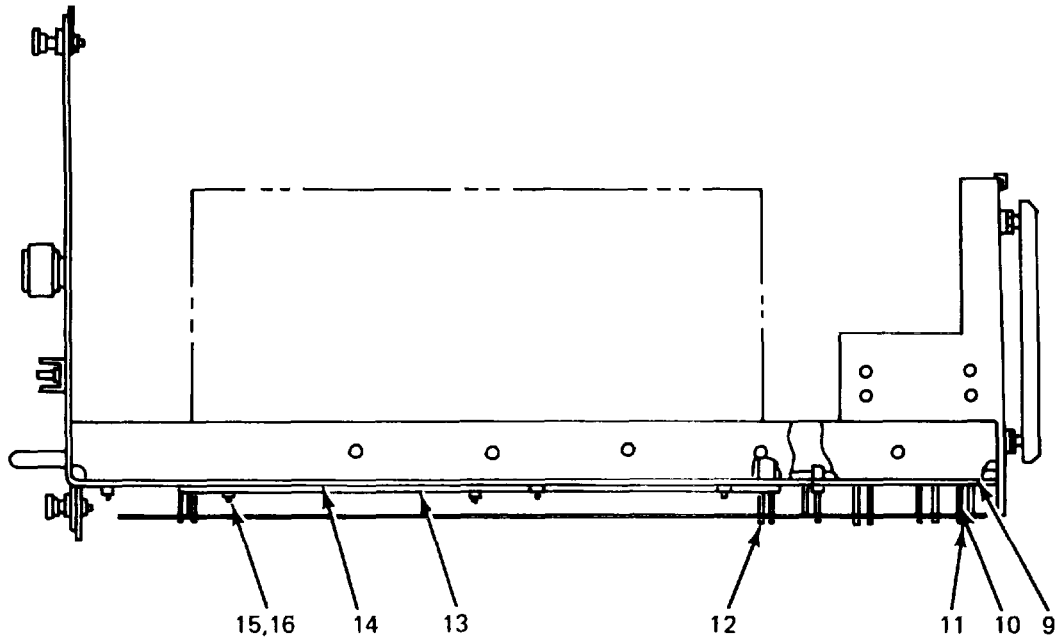

SIDE VIEW

ELOQM026

Figure 20. Logic Assembly (A64504-003).

SECTION II

TM 11-7440-222-40P/NAVELEX 0967-LP-324-0480/TO 31W4-2G-84

(1) ILLUSTRATION		(2)	(3)	(4)	(5)	(6) DESCRIPTION	(7)	(8)
(a) FIG NO.	(b) ITEM NO.	SMR CODE	NATIONAL STOCK NUMBER	PART NUMBER	FSCM	USABLE ON CODE	U/M	QTY INC IN UNIT
						GROUP 012001 LOGIC ASSEMBLY(A64504-003)		
20	1	XDHZZ		SN8546132	80063	SPACER.....	EA	1
20	2	PAHZZ	5305-00-054-6652	MS51957-28	96906	SCREW,MACHINE.....	EA	8
20	3	PAHZZ	5310-00-638-9857	AN960C6L	88044	WASHER,FLAT.....	EA	8
20	4	PAHZZ	5310-00-929-6395	MS35338-136	96906	WASHER,LOCK.....	EA	8
20	5	PAHZZ	5940-00-827-2653	MS77068-2	96906	TERMINAL,LUG.....	EA	9
20	6	XDHZZ		200150-001	16512	INSULATOR.....	EA	21
20	7	PAHZZ	5305-00-054-6651	MS51957-27	96906	SCREW,MACHINE.....	EA	38
20	8	PAHZZ	5325-00-813-2050	MS35490-32	96906	GROMMET,RUBBER.....	EA	2
20	9	XDHHH		A64533-001	58189	PLATE,CONTACT.....	EA	1
20	10	XDHZZ		550056-01	16512	INSULATOR.....	EA	12
20	11	XDHZZ	5999-00-139-2510	540123-03	16512	CONTACT,ELECTRICAL.....	EA	12
20	12	PAHZZ	5999-00-13-5933	540111-04	16512	CONTACT,ELECTRICAL.....	EA	20
20	13	XDHZZ		SMD634807-2	80063	STRIP,INSULATING.....	EA	1
20	1	XDHZZ		A53855-001	58189	BUSS BAR.....	EA	1
20	15	XDHZZ		SMB546299	80063	NUT,PLAIN,HEXAGON.....	EA	1
20	16	PAHZZ	5305-00-582-6151	MS18212-30	96906	SCREW,MACHINE.....	EA	1
					51			

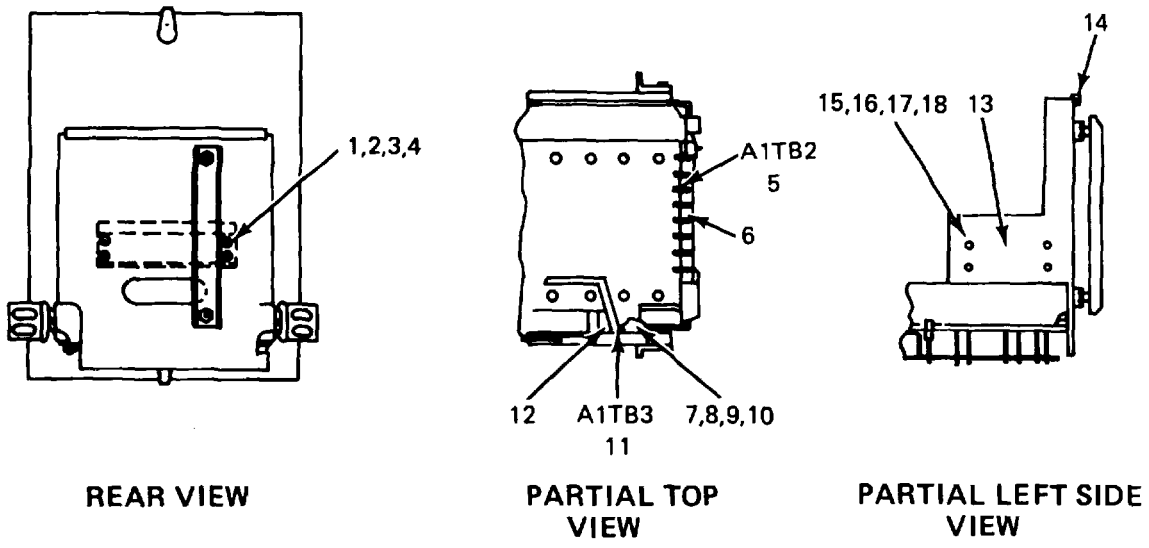

Figure 21. Logic Assembly (A64504-004).

ELOQM027

SECTION II

TM 11-7440-222-40P/NAVELEX 0967-LP-324-0480/TO 31W4-2G-84

(1) ILLUSTRATION		(2)	(3)	(4)	(5)	(6) DESCRIPTION	(7)	(8)
(a) FIG NO.	(b) ITEM NO.	SMR CODE	NATIONAL STOCK NUMBER	PART NUMBER	FSCM	USABLE ON CODE	U/M	QTY INC IN UNIT
						GROUP 012002 LOGIC ASSEMBLY(A64504-004)		
21	1	PAHZZ	5305-00-054-6672	MS51957-47	96906	SCREW,MACHINE.....	EA	4
21	2	PAHZZ	5310-00-933-8119	MS35338-137	96906	WASHER,LOCK	EA	4
21	3	PAHZZ	5310-00-558-6207	AN960C8L	88044	WASHER,FLAT	EA	4
21	4	PAHZZ	5310-00-934-9759	MS35649-284	96906	NUT,PLAIN,HEXAGON.....	EA	4
21	5	XDHZZ		602C-3/4ST7UH	75382	TERMINAL BOARD.....	EA	1
21	6	XDHZZ		MS602-7XXXP1A	96906	MARKER,STRIP.....	EA	1
21	7	PAHZZ	5310-00-934-9765	MS35650-304	96906	NUT,PLAIN,HEXAGON.....	EA	4
21	8	PAHZZ	5305-00059-3665	MS51958-69	96906	SCREW,MACHINE.....	EA	2
21	9	PAHZZ	5310-00-167-0812	AN960C10L	88044	WASHERFLAT	EA	4
21	10	PAHZZ	5310-00-933-8120	MS35338-138	96906	WASHER,LOCK	EA	4
21	11	XDHHZ		603-C-3UH	75382	TERMINAL BOARD.....	EA	1
21	12	XDHZZ		MS603-3XXXP1A	96906	STRIP,MARKER.....	EA	1
21	13	XDHZZ		A61706-005	58189	CHASSIS.....	EA	1
21	14	XDHZZ		203413-5	82654	TRIM,PLASTIC.....	EA	1
21	15	PAHZZ	5310-00-638-9857	AN960C6L	88044	WASHER,FLAT	EA	8
21	16	PAHZZ	5310-00-929-6395	MS35338-136	96906	WASHER,LOCK	EA	8
21	17	PAHZZ	5310-00-934-9761	MS35649-26	96906	NUT,PLAIN,HEXAGON.....	EA	8
21	18	PAHZZ	5305-00-054-6657	MS51957-33	96906	SCREW,MACHINE.....	EA	8
					53			

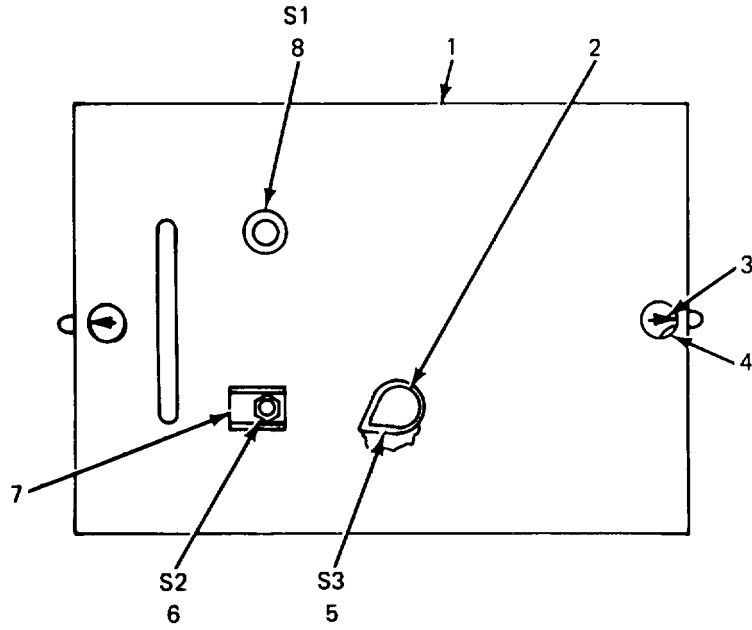

FRONT VIEW

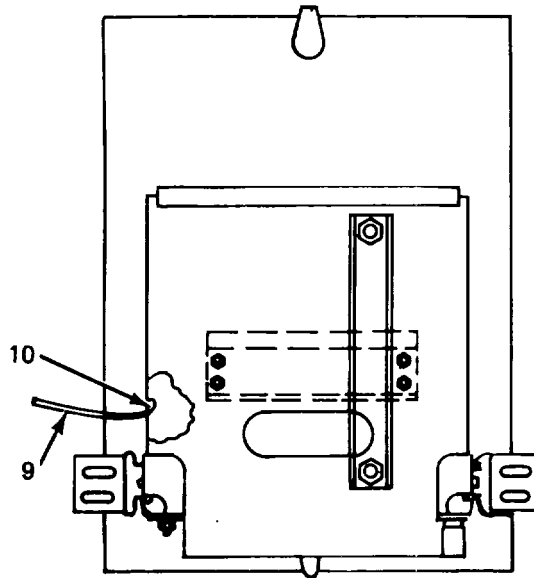

REAR VIEW

EL0QM028

Figure 22. Front Panel Assembly.

SECTION II

TM 11-7440-222-40P/NAVELEX 0967-LP-324-0480/TO 31W4-2G-84

(1) ILLUSTRATION		(2)	(3)	(4)	(5)	(6) DESCRIPTION	(7)	(8)
(a) FIG NO.	(b) ITEM NO.	SMR CODE	NATIONAL STOCK NUMBER	PART NUMBER	FSCM	USABLE ON CODE	U/M	QTY INC IN UNIT
						GROUP 012003 FRONT PANEL ASSEMBLY		
22	1	XDHZZ		A64514-001	98189	PANEL,BLANK	EA	1
22	2	PAHZZ	5355-00-559-8943	MS91528-2K2B	96906	KNOB	EA	1
22	3	PAHZZ	5340-00-684-9956	49-1-1-0	94222	LATCH SET,RIM	EA	7
22	4	PAHZZ	5310-00-531-9515	AN960C416	88044	WASHER,FLAT	EA	8
22	5	PAHZZ	5930-00-102-5733	810002-080	12436	SWITCH,ROTARY	EA	1
22	6	PAHZZ	5930-00-234-9199	8824K14	15605	SWITCH,TOGGLE	EA	1
22	7	PAHZZ	5930-00-687-1079	MS24417-1	96906	GUARD,SWITCH	EA	1
22	8	PAHZZ	5930-00-931-0514	4535-100-1B	96182	SWITCH,PUSH	EA	1
22	9	XDHZZ		A65406-001	58189	WIRING HARNESS	EA	1
22	10	PAHZZ	5940-00-204-9142	MS25036-12	96906	TERMINAL,LUG	EA	21
					55			

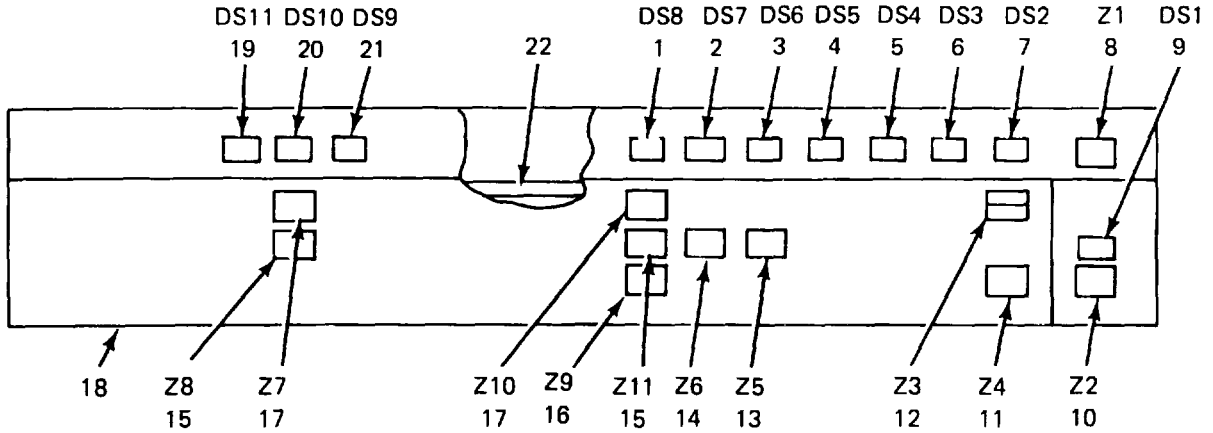

FRONT PANEL

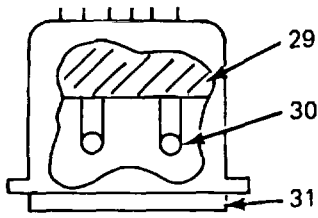

INDICATOR LIGHT
TYPICAL

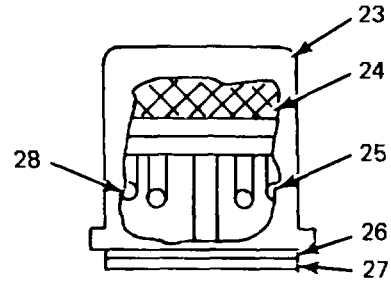

SWITCH
TYPICAL

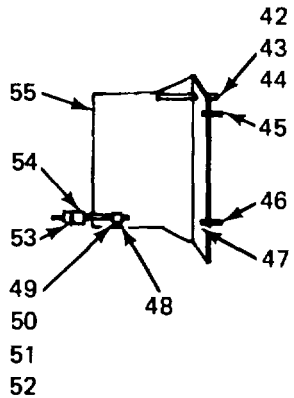

BRACKET

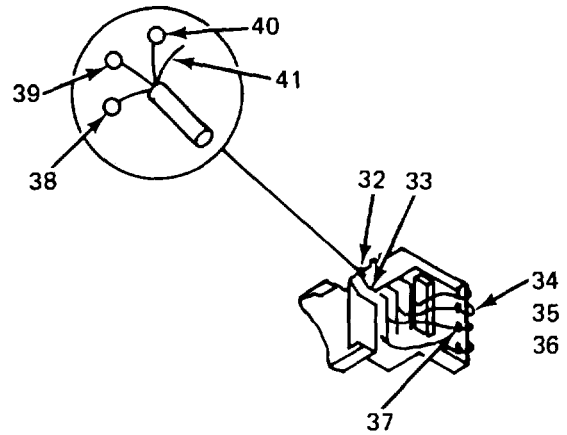

HARNES

EL0QM029

Figure 23. Control Panel A2 and Wiring Harness (A65411-001).

SECTION II

TM 11-7440-22-40P/NAVELEX 0967-LP-324-0480/TO 31W4-2G-84

(1) ILLUSTRATION		(2)	(3)	(4)	(5)	(6) DESCRIPTION	(7)	(8)
(a) FIG NO.	(b) ITEM NO.	SMR CODE	NATIONAL STOCK NUMBER	PART NUMBER	FSCM	USABLE ON CODE	U/M	QTY INC IN UNIT
GROUP 02 CONTROL PANEL A2								
23	1	XDHHH		80EA1F1AL2N13 NOTASSIGNED	96182	LIGHT, INDICATOR	EA	1
23	2	XDHHH		80EA1F1AL2N13 LOWTAPE	96182	LIGHT, INDICATOR	EA	1
23	3	XDHHH		80EA1F1RL2N13 TAPEOUT	96182	LIGHT, INDICATOR	EA	1
23	4	XDHHH		80EA1F1RL2N1 MOTIONFAIL	96182	LIGHT, INDICATOR	EA	1
23	5	XDHHH		80EA1F1RL2N13 PUNCHERROR	96182	LIGHT, INDICATOR	EA	1
23	6	XDHHH		80EA1F1RL2N13 PARITYERROR	96182	LIGHT, INDICATOR	EA	1
23	7	XDHHH		80EA1F1RL2N13 PUNCHFUSE	96182	LIGHT, INDICATOR	EA	1
23	8	XDHHH		1197-34	96182	SWITCH, PUSH BUTTON.....	EA	1
23	9	XDHHH		80EA1F1WL2N13 DCPOWER	96182	LIGHT, INDICATOR	EA	1
23	10	XDHHH		1197-32	96182	SWITCH, PUSH BUTTON.....	EA	1
23	11	XDHHH		1197-33	96182	SWITCH, PUSH BUTTON.....	EA	1
23	12	XDHHH		1197-39	96182	SWITCH, PUSH BUTTON.....	EA	1
23	13	XBHHH		1197-41	96182	SWITCH, PUSH BUTTON.....	EA	1
23	14	XDHHH		1197-40	96182	SWITCH, PUSH BUTTON.....	EA	1
23	15	XDHHH		1197-31	96182	SWITCH, PUSH BUTTON.....	EA	2
23	16	XDHHH		1197-37	96182	SWITCH, PUSH BUTTON.....	EA	1
23	17	XDHHH		119-30	96182	SWITCH, PUSH BUTTON.....	EA	2
23	18	XDHZZ		A6518-001	58189	CONTROL PANEL	EA	1
23	19	XDHZZ		80EA1F1AL2N13 PRINTFAIL	96182	LIGHT, INDICATOR	EA	1
23	20	XDHZZ		80A1F1AL2N13 SLACKTAPE	96182	LIGHT, INDICATOR	EA	1
23	21	XDHZZ		80EA1F1RL2N13 TIGHTTAPE	96182	LIGHT, INDICATOR	EA	1
23	22	XDHHH		A65411-001	58189	WIRING HARNESS.....	EA	1
23	23	PAHZZ	6605-00-941-0561	10EA1C1	96182	SWITCH LITE.....	EA	11
23	24	PAHZZ	5930-00-920-5995	10EF3	96182	SWITCH, SENSITIVE USED ON PART NO. 1197-39.....	EA	1
23	24	PAHZZ	5930-00-959-3427	10EF1	96182	SWITCH, SENSITIVE USED ON SWITCHES PART NOS. 1197-30 THRU-34, -37, -40, -41 NO. 1197-31	EA	10
23	25	XDHZZ	6210-00-181-2533	10ELR00R	96182	FILTER, INDICATOR LI USED ON SWITCH NO. 1197-31	EA	8
23	25	XDHZZ	6210-00-181-2532	10ELW00W	96182	FILTER, INDICATOR LI USED ON SWITCH NO. 1197-32.....	EA	4
23	25	XDHZZ	5930-00-781-2916	10ELA00A	96182	CAP, COLOR FILTER USED ON SWITCH NO.1197-41	EA	8
23	25	XDHZZ	5930-00-781-2916	10ELA00A	96182	CAP, COLOR FILTER USED IN SWITCHES PART NOS. 1197-37 AND 1197-41	EA	1
23	25	XDHZZ		10ELW000W	96182	COLORED BULB FILTER USED ON PART NO. 1197-39.....	EA	4
23	25	XDHZZ	6210-00-181-235	10ELW000W	96182	FILTER, INDICATOR LI USED ON SWITCH PART NO. 1197-30.....	EA	2
23	26	XDHZZ		10EN2	96182	LENS, LIGHT USED ON PART NO 1197-39 ..	EA	1

SECTION II

TM 11-7440-22-40P/NAVELEX 0967-LP-324-0480/TO 31W4-2G-84

(1) ILLUSTRATION		(2)	(3)	(4)	(5)	(6) DESCRIPTION	(7)	(8)
(a) FIG NO.	(b) ITEM NO.	SMR CODE	NATIONAL STOCK NUMBER	PART NUMBER	FSCM	USABLE ON CODE	U/M	QTY INC IN UNIT
23	26	XDHZZ	6210-00-497-2091	10EN1	96182	LENS, LIGHT USED ON SWITCHES PART NOS. 1197-30 THRU -34, -37, -40, -41	EA	10
23	27	XDHZZ		10ER1T5V12STOP	96182	FRONT LENS USED ON SWITCH NO. 1197-31	EA	2
23	27	XDHZZ		10ER1T5V13AC POWER	96182	FRONT LENS USED ON SWITCH NO. 1197-32	EA	1
23	27	XDHZZ		10ER1TS513PRINT 1DEPENDENT	96182	FRONT LENS USED ON SWITCH NO. 1197-41	EA	1
23	27	XDHZZ		10ER1TV13LOCAL TEST	96182	FRONT LENS USED ON SWITCH NO. 1197-37	EA	1
23	27	XDHZZ		10ER1T5V16WIDE/ NARROW	96182	FRONT LENS USED ON SWITCH NO. 1197-39	EA	1
23	27	XDHZZ		10ER1T5V13LAMP TEST	96182	FRONT LENS USED ON SWITCH NO. 1197-33	EA	1
23	27	XDHZZ		10ER1T5V13AUDI BLERESSET	96182	FRONT LENS USED ON SWITCH NO. 1197-34	EA	1
23	27	XDHZZ		10EA1T5V13FEED OUT	96182	FRONT LENS USED ON SWITCH NO.1197-40	EA	1
23	27	XDHZZ		10ER1T5V12ST ART	96182	FRONT LENS USED ON SWITCH NO. 1197-30	EA	2
23	28	PAHZZ	6240-00-851-4352	330	08806	LAMP, INCANDESCENT.....	EA	46
23	29	PAHZZ	6210-00-019-5599	80EA1	96182	LIGHT, INDICATOR	EA	11
23	30	PAHZZ	6210-00-927-3688	80EF1W	96182	FILTER INDICATOR LI USED ON INDICATOR LIGHT PART NO. 80EA1F1WL2N13DCPOWER	EA	1
23	30	PAHZZ	6210-00-927-3519	80EF1A	96182	FILTER INDICATOR LI USED ON INDICATOR LIGHTS PART NOS. 80EA1F1AL2N13NOTASSIGN NED, LOWTAPE, PRINTFAIL, SLACKTAPE ..	EA	4
23	30	PAHZZ	6210-00-011-9338	80EF1R	96182	FILTER, DISPLAY SCRE USED ON INDICATOR LIGHTS PART NOS. 80EA1F1RL2N13MOTION FAIL, TIGHTTAPE, TAPEOUT, PARITYERROR, PUNCHERROR, PUNCHFUSE.....	EA	6
23	31	XDHZZ		80EL2N13LOW TAPE	96182	FRONT LENS USED ON INDICATOR LIGHT PART NO. 80EA1F1AL2N13LOWTAPE	EA	1
23	31	XDHZZ	6210-00-183-0303	80EL2N13DC POWER	96182	LENS, LIGHT USED ON INDICATOR LIGHT PART NO. 80EA1F1W12N13DCPOWER	EA	1
23	31	XDHZZ	6210-00-183-0299	80EL2N13NOT ASSIGNED	96182	LENS, LIGHT USED ON INDICATOR LIGHT PART NO.80EA1F1AL2N13NOTASSIGNED	EA	1
23	31	XDHZZ		80EL2N13MOTION FAIL	96182	FRONT LENS USED ON INDICATOR LIGHT PART NO. 80EA1F1RL2N13MOTIONFAIL.....	EA	1
23	31	XDHIZ		80EL2N13TIGHT TAPE	96182	FRONT LENS USED ON INDICATOR LIGHT PART NO. 80EA1F1RL2N13TIGHTTAPE.....	EA	1
23	31	XDHZZ		80EL2N13TAPE OUT	96182	FRONT LENS USED ON INDICATOR LIGHT PART NO. 80EA1F1RL2N13TAPEOUT.....	EA	1
23	31	XDHZZ	6210-00-183-0305	80EL2N13PARITY ERROR	96182	LENS, LIGHT USED ON INDICATOR LIGHTPART NO. 80EA1F1RL2N13PARTITYERROR	EA	1
23	31	XDHZZ		80EL2N13PUNCH ERROR	96182	FRONT LENS USED ON INDICATOR LIGHT PART NO. 08EA1F1RL2N13PUNCHERROR.	EA	1
23	31	XDHZZ	6210-00-183-0300	80EL2N13PRINT FAIL	96182	LENS, LIGHT USED ON INDICATOR LIGHT PART NO. 80EA1F1AL2N13PRINTFAIL	EA	1
23	31	XDHZZ		80EL2N13SLACK TAPE	96182	FRONT LENS USED ON INDICATOR LIGHT PART NO. 80EA1F1AL2N13SLACKTAPE.....	EA	1
23	31	XDHZZ		80EL2N13PUNCH FUSE	96182	FRONT LENS USED ON INDICATOR LIGHT PART NO. 80EA1F1RL2N13PUNCHFUSE	EA	1
23	32	PAHHH	5999-00-933-5070	A53847-001	58189	GROUP 0201 WIRING HARNESS (A65411-001) CONTACT ASSEMBLY, EL.....	EA	4

SECTION II

TM 11-7440-22-40P/NAVELEX 0967-LP-324-0480/TO 31W4-2G-84

(1) ILLUSTRATION		(2)	(3)	(4)	(5)	(6) DESCRIPTION	(7)	(8)
(a) FIG NO.	(b) ITEM NO.	SMR CODE	NATIONAL STOCK NUMBER	PART NUMBER	FSCM	USABLE ON CODE	U/M	QTY INC IN UNIT
23	33	XDHZZ	5340-00-782-8737	CPC1953-4A	71616	CLAMP, LOOP	EA	1
23	34	PAHZZ	5310-00-934-9765	MS35650-304	96906	NUT, PLAIN, HEXAGON	EA	1
23	35	PAHZZ	5310-00-933-8120	MS35338-138	96906	WASHER, LOCK	EA	1
23	36	PAHZZ	5310-00-167-0812	AN960C10L	88044	WASHER, FLAT	EA	1
23	37	PAHZZ	5340-00-969-6501	CPC1953-78	71616	CLAMP, LOOP	EA	2
23	38	XDHZZ		MS25036-6	96906	TERMINAL, LUG	EA	1
23	39	PAHZZ	5940-00-577-3711	MS25036-3	96906	TERNINAL, LUG	EA	10
23	40	PAHZZ	5940-00-813-0698	MS25036-1	96906	TERNINAL, LUG	EA	11
23	41	XDHZZ		SMB634809	80063	JUMPER	EA	11
23	42	XDHZZ		SMB546131	80063	SCREW, EXT RLV BODY	EA	8
23	43	PAHZZ	5310-00-638-9857	AN960C6L	88044	WASHER, FLAT	EA	4
23	44	PAHZZ	5310-00-929-6395	MS35338-136	96906	WASHER, LOCK	EA	4
23	45	XDHZZ		SMB546216	80063	PIN, KEYING	EA	4
23	46	PAHZZ	7440-00-019-3468	540362-06	16512	CONTACT, ELECTRICAL	EA	145
23	47	XDHZZ		P550009-09	16512	INSULATOR, BUSHING	EA	1
23	48	PAHZZ	5340-00-598-0296	HP7N	09922	CLAMP, LOOP	EA	1
23	49	XDHZZ		MS35649-144	96906	NUT, PLAIN, HEXAGON	EA	4
23	50	PAHZZ	5310-00-933-8118	MS35338-135	96906	WASHER, LOCK	EA	4
23	51	PAHZZ	5310-00-782-1349	AN960C4	88044	WASHER, FLAT	EA	4
23	52	PAHZZ	5305-00-770-2580	MS51959-16	96906	SCREW, MACHINE	EA	4
23	53	PAHZZ	5975-00-497-2158	MS17821-1-9	96906	STRAP, TIEDOWN, ELECT	EA	4
23	54	XDHZZ		TC125	59730	NAMEPLATE	EA	11
23	55	XDHZZ		A53846-001	58189	BRACKET, ANGLE	EA	4

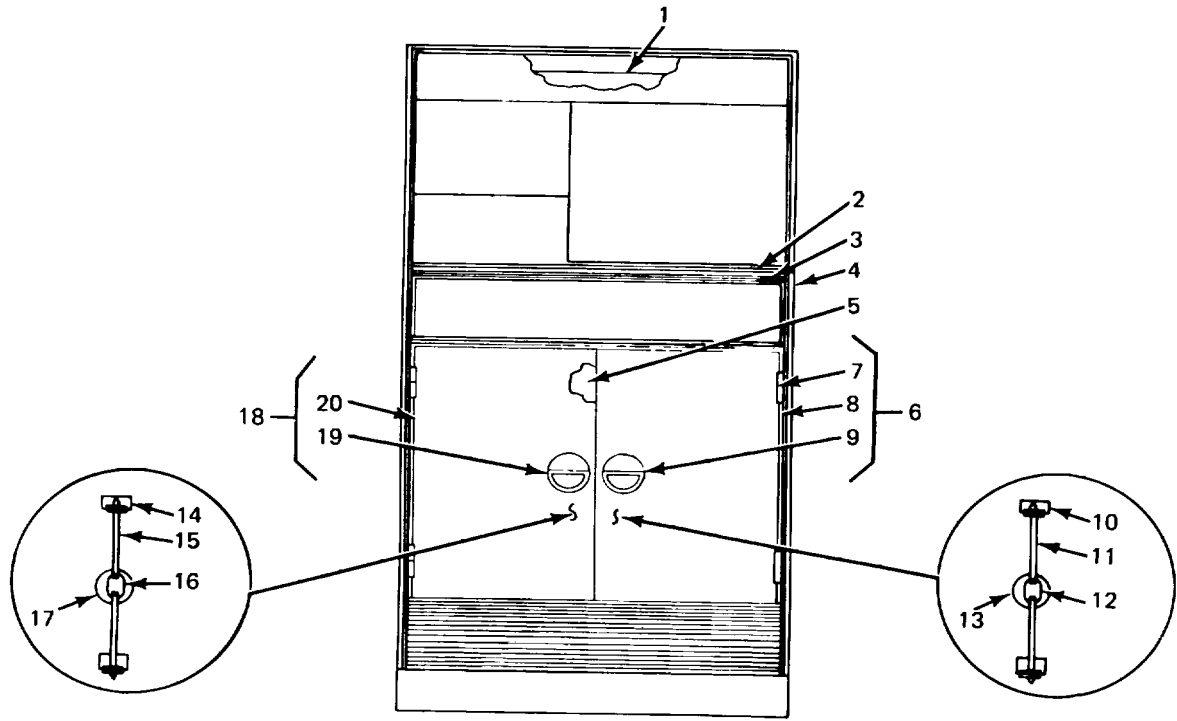

FRONT VIEW

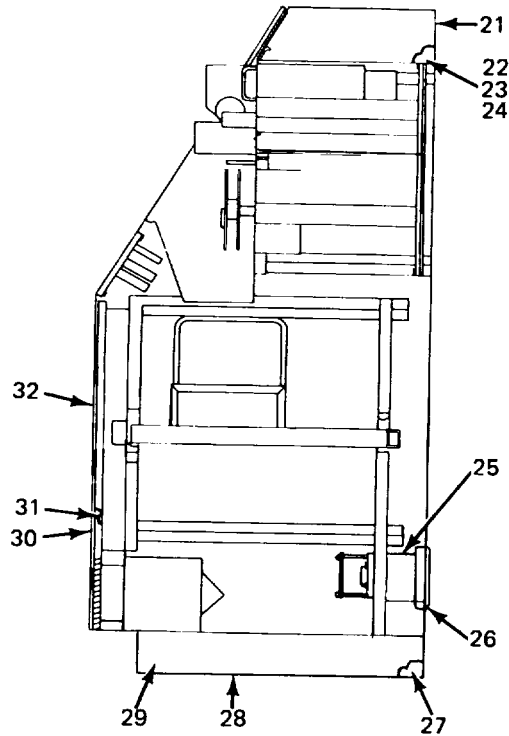

SIDE VIEW

ELOQM030

Figure 24. Enclosure.

SECTION II

TM 11-7440-22-40P/NAVELEX 0967-LP-324-0480/TO 31W4-2G-84

(1) ILLUSTRATION		(2)	(3)	(4)	(5)	(6)	(7)	(8)
(a) FIG NO.	(b) ITEM NO.	SMR CODE	NATIONAL STOCK NUMBER	PART NUMBER	FSCM	DESCRIPTION USABLE ON CODE	U/M	QTY INC IN UNIT
						GROUP 03 ENCLOSURE		
24	1	XDHHH		600502	05439	CHASSIS, ELEC, EQPT.....	EA	1
24	2	PAHZZ	530-00-984-7361	MS35191-270	96906	SCREW, MACHINE.....	EA	3
24	3	XDHZZ		600110-1	05439	TRIM, LOGO.....	EA	1
24	4	XDHZZ		600504	05439	STRIP, LOGO.....	EA	1
24	5	XDHZZ		1178-2	70485	BUMPER, RUBBER.....	EA	2
24	6	XDHHH		600002-2	05439	DOOR ASSEMBLY, RH.....	EA	1
24	7	XDHZZ		600105-4	05439	PIN, STRAIGHT, HDLS.....	EA	8
24	8	XDHZZ		600002-3	05439	DOOR.....	EA	1
24	9	XDHZZ		600111-1	05439	HANDLE.....	EA	2
24	10	XDHZZ		600112-1	05439	GROMMET, NYLON.....	EA	1
24	11	XDHZZ		600111-3	05439	ROD.....	EA	1
24	12	XDHZZ		600111-2	05439	CAM.....	EA	1
24	13	XDHZZ		600503-5	05439	LINER, MYLAR.....	EA	1
24	14	XDHZZ		600112-1	05439	GROMMET NYLON.....	EA	4
24	15	XDHZZ		600111-3	05439	ROD.....	EA	4
24	16	XDHZZ		600111-2	05439	CAM.....	EA	2
24	17	XDHZZ		600002-5	05439	LINER, MYLAR.....	EA	1
24	18	XDHHH		600503-1	05439	DOOR ASSEMBLY, LH.....	EA	1
24	19	XDHZZ		600111-1	05439	HANDLE.....	EA	1
24	20	XDHZZ		600503-3	05439	DOOR.....	EA	1
24	21	XDHZZ		600108-1	05439	PANEL, REAR.....	EA	1
24	22	PAHZZ	5305-00-059-3659	MS51958-63	96906	SCREW, MACHINE.....	EA	6
24	23	PAHZZ	5310-00-167-0801	AN960C10	88044	WASHER, FLAT.....	EA	6
24	24	PAHZZ	5310-00-933-8120	MS35338-138	96906	WASHER, LOCK.....	EA	10
24	25	XDHZZ		600102-1	05439	PLATE, MOUNTING.....	EA	1
24	26	PAHZZ	5310-00-934-9765	MS35650-304	96906	NUT, PLAIN, HEXAGON.....	EA	10
24	27	XDHZZ	5305-00-721-4747	MS24618-40	96906	SCREW TAPPING THREA.....	EA	4
24	28	XDHZZ		600103-1	05439	PLATE, SUPPORT.....	EA	1
24	29	XDHZZ		600100-1	05439	BASE.....	EA	1
24	30	XDHZZ		600109-1	05439	TRIM, METAL.....	EA	2
24	31	XDHZZ	5340-00-451-9149	C29943-014-1	78553	CLIP.....	EA	4
24	32	XDHZZ		600109-2	05439	TRIM, METAL.....	EA	2

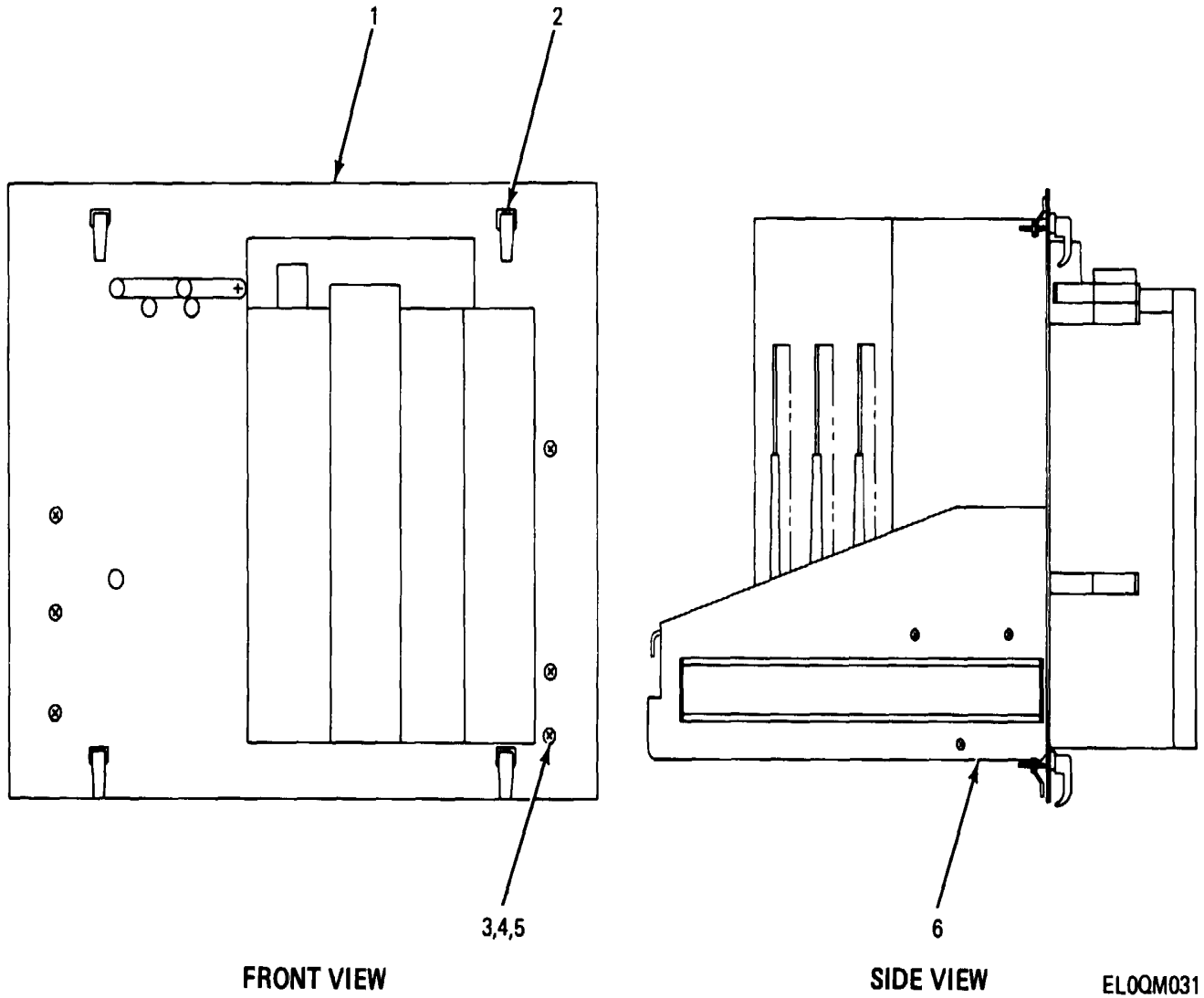
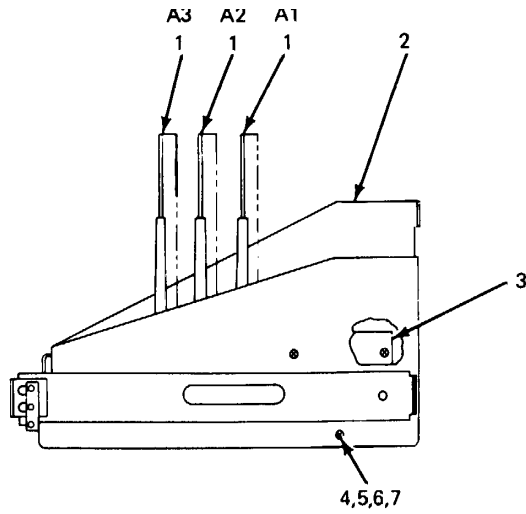

Figure 25. Punch Assembly A4.

SECTION II

TM 11-7440-22-40P/NAVELEX 0967-LP-324-0480/TO 31W4-2G-84

(1) ILLUSTRATION		(2)	(3)	(4)	(5)	(6)	(7)	(8)
(a) FIG NO.	(b) ITEM NO.	SMR CODE	NATIONAL STOCK NUMBER	PART NUMBER	FSCM	DESCRIPTION USABLE ON CODE	U/M	QTY INC IN UNIT
						GROUP 04 PUNCH ASSEMBLY A4		
25	1	XAHHD	7040-00-165-6534	331940	12344	PUNCH MECHANISM, LOW	EA	1
25	2	XDHZZ		62-99-220-30	24248	LATCH, HANDLE	EA	4
25	3	PAHZZ	5310-00-933-8119	MS35338-137	96906	WASHER, LOCK	EA	6
25	4	PAHZ	5310-00-558-6207	AN960C8L	88044	WASHER, FLAT	EA	6
25	5	PAHZZ	5305-00-054-6672	MS51957-47	96906	SCREW, MACHINE	EA	6
25	6	XDHHH		A64511-001	58189	DRIVER ASSY, PUNCH	EA	1



SIDE VIEW

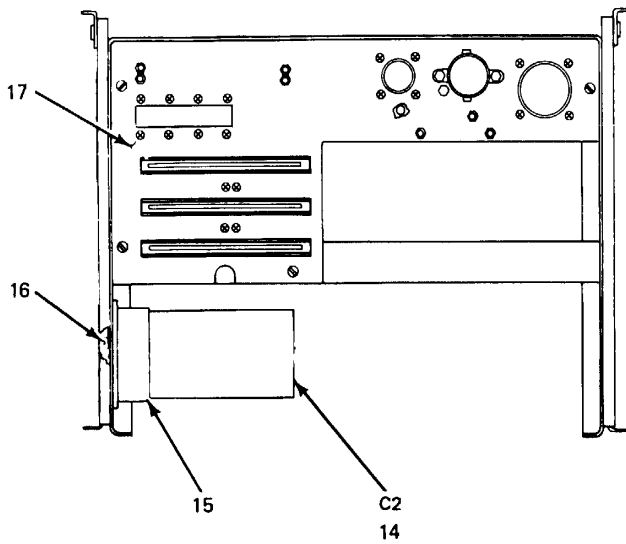

TOP VIEW

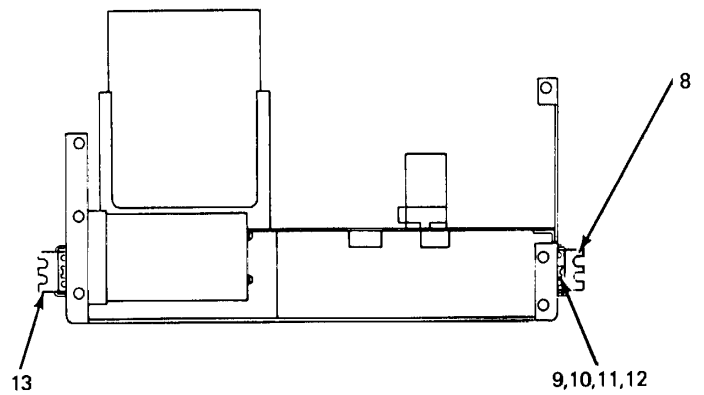

FRONT VIEW

EL0QM032

Figure 26. Driver Assembly, Punch.

SECTION II

TM 11-7440-22-40P/NAVELEX 0967-LP-324-0480/TO 31W4-2G-84

(1) ILLUSTRATION		(2)	(3)	(4)	(5)	(6) DESCRIPTION	(7)	(8)
(a) FIG NO.	(b) ITEM NO.	SMR CODE	NATIONAL STOCK NUMBER	PART NUMBER	FSCM	USABLE ON CODE	U/M	QTY INC IN UNIT
						GROUP 0401 DRIVER ASSEMBLY, PUNCH		
26	1	PAHDL	7040-00-911-2515	A53506-001	12436	CIRCUIT CARD ASSEMB.....	EA	3
26	2	XDHZZ		A64526-001	58189	CHASSIS ASSEMBLY.....	EA	1
26	3	XDHZZ		A64522-001	58189	SPACER.....	EA	1
26	4	PAHZZ	5305-00-054-6671	MS51957-46	96906	SCREW MACHINE.....	EA	6
26	5	PAHZZ	5310-00-933-8119	MS35338-137	96906	WASHER, LOCK.....	EA	6
26	6	PAHZZ	5310-00-558-6207	AN960C8L	88044	WASHER, FLAT.....	EA	6
26	7	PAHZZ	5310-00-934-9759	MS35649-284	96906	NUT, PLAIN, HEXAGON.....	EA	6
26	8	XDHZZ		C300S14RTB	06666	SLIDE, RIGHT HAND.....	EA	1
26	9	PAHZZ	5310-00-934-9765	MS35650-304	96906	NUT, PLAIN, HEXAGON.....	EA	4
26	10	PAHZZ	5310-00-933-8120	MS35338-138	96906	WASHER, LOCK.....	EA	4
26	11	PAHZZ	5310-00-167-0812	AN960C10L	88044	WASHER, FLAT.....	EA	4
26	12	PAHZZ	5305-00-059-3658	MS51958-62	96906	SCREW, MACHINE.....	EA	7
26	13	XDHZZ		C300S14L	06666	SLIDE, LEFT HAND.....	EA	1
26	14	XDHZZ		360223P075DF6B	56289	CAPACITOR, ELCTLT.....	EA	1
26	15	PAHZZ	5910-00-995-9189	4586-2A	56289	RETAINER, CAPACITOR.....	EA	1
26	16	PAHZZ	5305-00-059-3655	MS51958-59	96906	SCREW, MACHINE.....	EA	1
26	17	XDHHH		A64524-002	58189	SHELF ASSEMBLY.....	EA	1

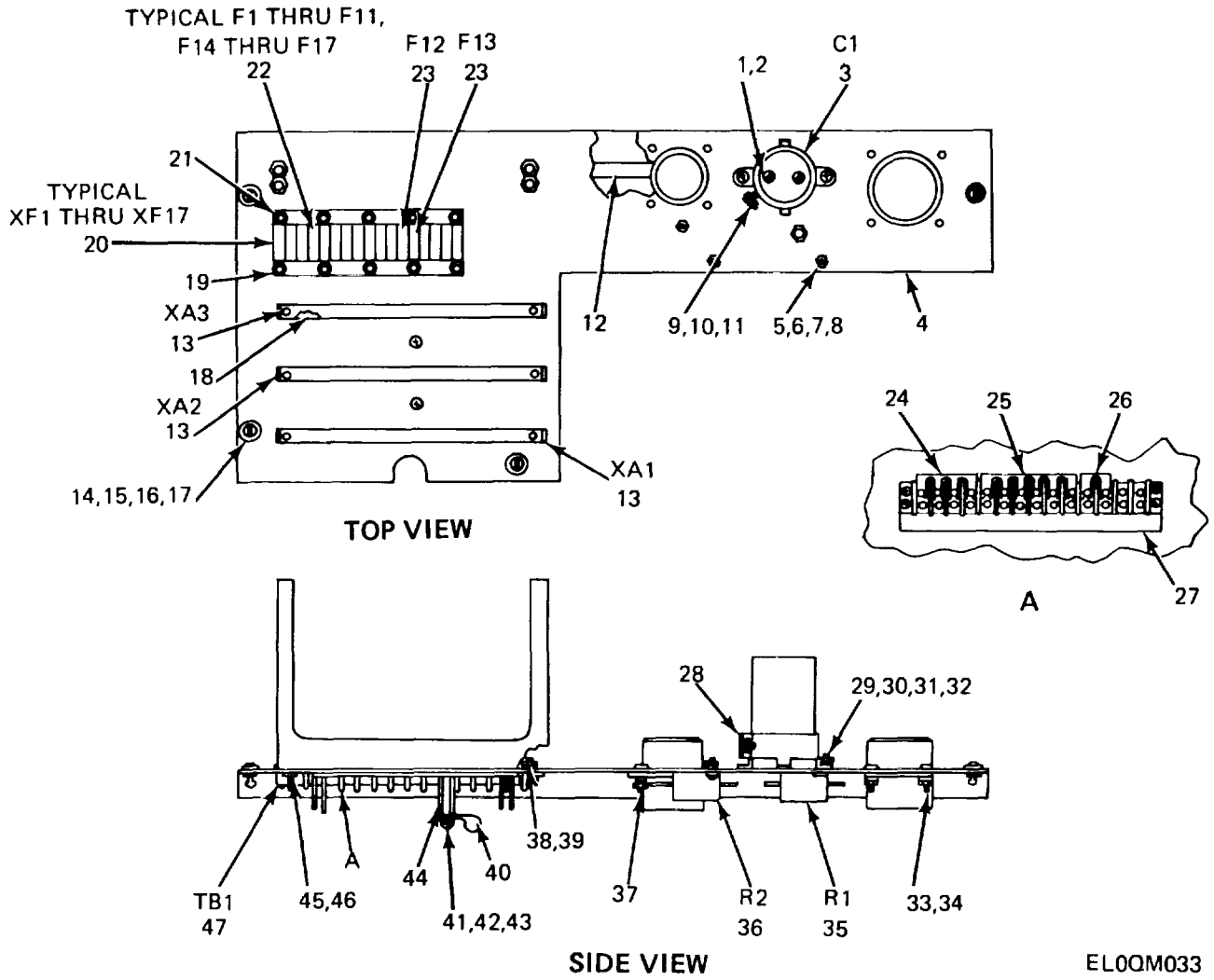

ELOQM033

Figure 27. Shelf Assembly.

SECTION II

TM 11-7440-22-40P/NAVELEX 0967-LP-324-0480/TO 31W4-2G-84

(1) ILLUSTRATION		(2)	(3)	(4)	(5)	(6)	(7)	(8)
(a) FIG NO.	(b) ITEM NO.	SMR CODE	NATIONAL STOCK NUMBER	PART NUMBER	FSCM	DESCRIPTION USABLE ON CODE	U/M	QTY INC IN UNIT
GROUP 040101 SHELF ASSEMBLY								
27	1	PAHZZ	5310-00-933-8120	MS35338-138	96906	WASHER, LOCK	EA	1
27	2	XDHZZ		639139-467	51889	SCREW, MACHINE	EA	2
27	3	PAHZZ	5910-00-833-6649	36D272G025AA6R	56289	CAPACITOR, ELCTLT	EA	1
27	4	XDHZZ		A64528-002	58189	SHELF	EA	1
27	5	PAHZZ	5305-00-054-5639	MS51957-5	96906	SCREW, MACHINE	EA	6
27	6	PAHZZ	5310-00-183-4354	AN960C2L	88044	WASHER, FLAT	EA	8
27	7	PAHZZ	5310-00-928-2690	MS35338-134	96906	WASHER, LOCK	EA	3
27	8	PAHZZ	5310-00-938-2013	MS35649-224	96906	NUT, PLAIN, HEXAGON	EA	4
27	9	PAHZZ	5310-00-929-6395	MS35338-136	96906	WASHER, LOCK	EA	3
27	10	PAHZZ	5310-00-934-9761	MS35649-264	96906	NUT, PLAIN, HEXAGON	EA	5
27	11	PAHZZ	5305-00-054-6656	MS51957-32	96906	SCREW, MACHINE	EA	2
27	12	XDHZZ		A65407-001	58189	WIRING HARNESS	EA	1
27	13	PAHZZ	5935-00-102-5690	200150-02	16512	CONNECTOR, RECEPTACL	EA	3
27	14	PAHZZ	5310-00-775-5245	82-46-101-39	94222	WASHER, RECESSED	EA	4
27	15	PAHZZ	5325-00-687-520P	2-0-220	94222	STUD, TURNLOCK FASTE	EA	4
27	16	PAHZZ	5310-00-845-5472	82-32-101-17	94222	WASHER, SPLIT	EA	4
27	17	PAHZZ	5360-00-773-6189	43-13-1-23	94222	SPRING, HELICAL, COMP	EA	4
27	18	PAHZZ	5315-00-162-4040	290050-01	16512	KEY, SPECIAL	EA	8
27	19	XDHZZ		A64530-001	58189	BAR, CLAMP	EA	2
27	20	PAHZZ	5920-00-968-3238	HLT	71400	FUSEHOLDER, BLOCK	EA	17
27	21	PAHZZ	5305-00-054-5652	MS51957-18	96906	SCREW, MACHINE	EA	21
27	22	PAHZZ	5920-00-995-6079	GMT1-2	71400	FUSE, INDICATOR ALAR	EA	15
27	23	PAHZZ	5920-00-023-2926	GTT18-100	74001	FUSE, INDICATOR ALAR	EA	2
27	24	PAHZZ	6150-00-959-2776	600RJS4	75382	LINK, TERMINAL CONNE	EA	1
27	25	XDHZZ	6150-00-416-8766	600RJS6	75382	BUS, CONDUCTOR	EA	1
27	26	PAHZZ	3010-00-075-5737	600RJS2	75382	LINK	EA	1
27	27	XDHZZ		MS600-14XXXP1A	75382	MARKER STRIP	EA	1
27	28	PAHZZ	5910-00-666-5781	4586-97A	56289	RETAINER, CAPACITOR	EA	1
27	29	PAHZZ	5305-00-054-5649	MS51957-15	96906	SCREW, MACHINE	EA	2
27	30	PAHZZ	5310-00-595-6425	AN960C4L	88044	WASHER, FLAT	EA	2
27	31	PAHZZ	5310-00-933-8118	MS35338-135	96906	WASHER, LOCK	EA	2
27	32	XDHZZ		MS35649-144	96906	NUT, PLAIN, HEXAGON	EA	2
27	33	PAHZZ	5305-00-054-6654	MS51957-30	96906	SCREW, MACHINE	EA	4
27	34	XDHZZ		AN96C6L	88044	WASHER, FLAT	EA	4
27	35	PAHZZ	5905-00-902-1229	RE65G82R5	81349	RESISTOR, FIXED, WIRE	EA	1
27	36	PAHZZ	5905-00-899-4081	RE70G4020	81349	RESISTOR, FIXED, WIRE	EA	1
27	37	PAHZZ	5305-00-054-5651	MS51957-17	96906	SCREW, MACHINE	EA	11
27	38	PAHZZ	5305-00-054-6655	MS51957-31	96906	SCREW, MACHINE	EA	8
27	39	PAHZZ	5310-00-722-5998	MS15795-805	96906	WASHER, FLAT	EA	8

SECTION II

TM 11-7440-22-40P/NAVELEX 0967-LP-324-0480/TO 31W4-2G-84

(1) ILLUSTRATION		(2)	(3)	(4)	(5)	(6)	(7)	(8)
(a) FIG NO.	(b) ITEM NO.	SMR CODE	NATIONAL STOCK NUMBER	PART NUMBER	FSCM	DESCRIPTION USABLE ON CODE	U/M	QTY INC IN UNIT
27	40	PAHZZ	5340-00-366-8164	HP10N	09922	CLAMP, LOOP	EA	9
27	41	PAHZZ	5305-00-054-6668	MS51957-43	96906	SCREW, MACHINE.....	EA	1
27	42	PAHZZ	5310-00-558-6207	AN960C8L	88044	WASHER, FLAT	EA	1
27	43	PAHZZ	5310-00-933-8119	MS35338-137	96906	WASHER, LOCK.....	EA	1
27	44	XDHZZ		A64531-001	58189	BRACKET.....	EA	1
27	45	PAHZZ	5310-00-638-9857	AN960C6L	88044	WAHER, FLAT	EA	4
27	46	PAHZZ	5305-00-054-6652	MS51957-28	96906	SCREW, MACHINE.....	EA	4
27	47	XDHZZ		600C-14UH	75382	TERMINAL BOARD.....	EA	1

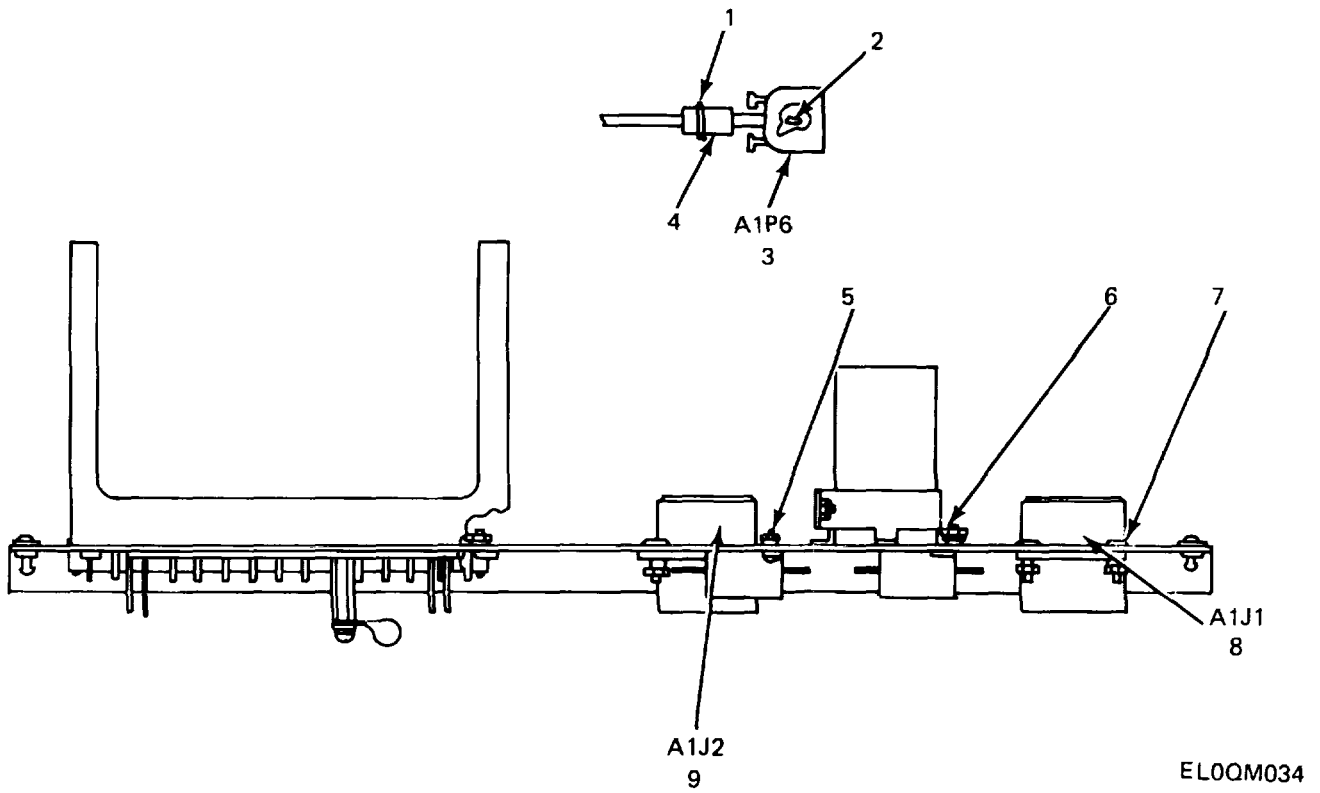

Figure 28. Wiring Harness (A65407-001).

SECTION II

TM 11-7440-22-40P/NAVELEX 0967-LP-324-0480/TO 31W4-2G-84

(1) ILLUSTRATION		(2)	(3)	(4)	(5)	(6) DESCRIPTION	(7)	(8)
(a) FIG NO.	(b) ITEM NO.	SMR CODE	NATIONAL STOCK NUMBER	PART NUMBER	FSCM	USABLE ON CODE	U/M	QTY INC IN UNIT
						GROUP 0401010 WIRING HARNESS (A65407-001)		
28	1	PAHZZ	5975-00-497-2158	MS17821-1-9	96906	STRAP, TIEDOWN, ELECT	EA	1
28	2	PAHZZ	5940-00-113-8199	2-323934-2	00719	FERRULE	EA	3
28	3	PAHZZ	5935-00-850-0813	P34S23JTLHFL	10400	CONNECTOR, PLUG, ELEC	EA	1
28	4	XDHZZ		TC125	59730	NAMEPLATE	EA	1
28	5	PAHZZ	5940-00-204-9142	MS25036-12	96906	TERMINAL, LUG	EA	1
28	6	PAHZZ	5940-00-577-3711	MS25036-3	96906	TERMINAL, LUG	EA	1
28	7	PAHZZ	5940-00-813-0698	MS25036-1	96906	TERMINAL, LUG	EA	1
28	8	PAHZZ	5935-00-813-1782	MS3102R28-20P	96906	CONNECTOR, RECEPTACL	EA	1
28	9	PAHZZ	5935-00-721-0496	MS3102R22-14P	96906	CONNECTOR, RECEPTACL	EA	1

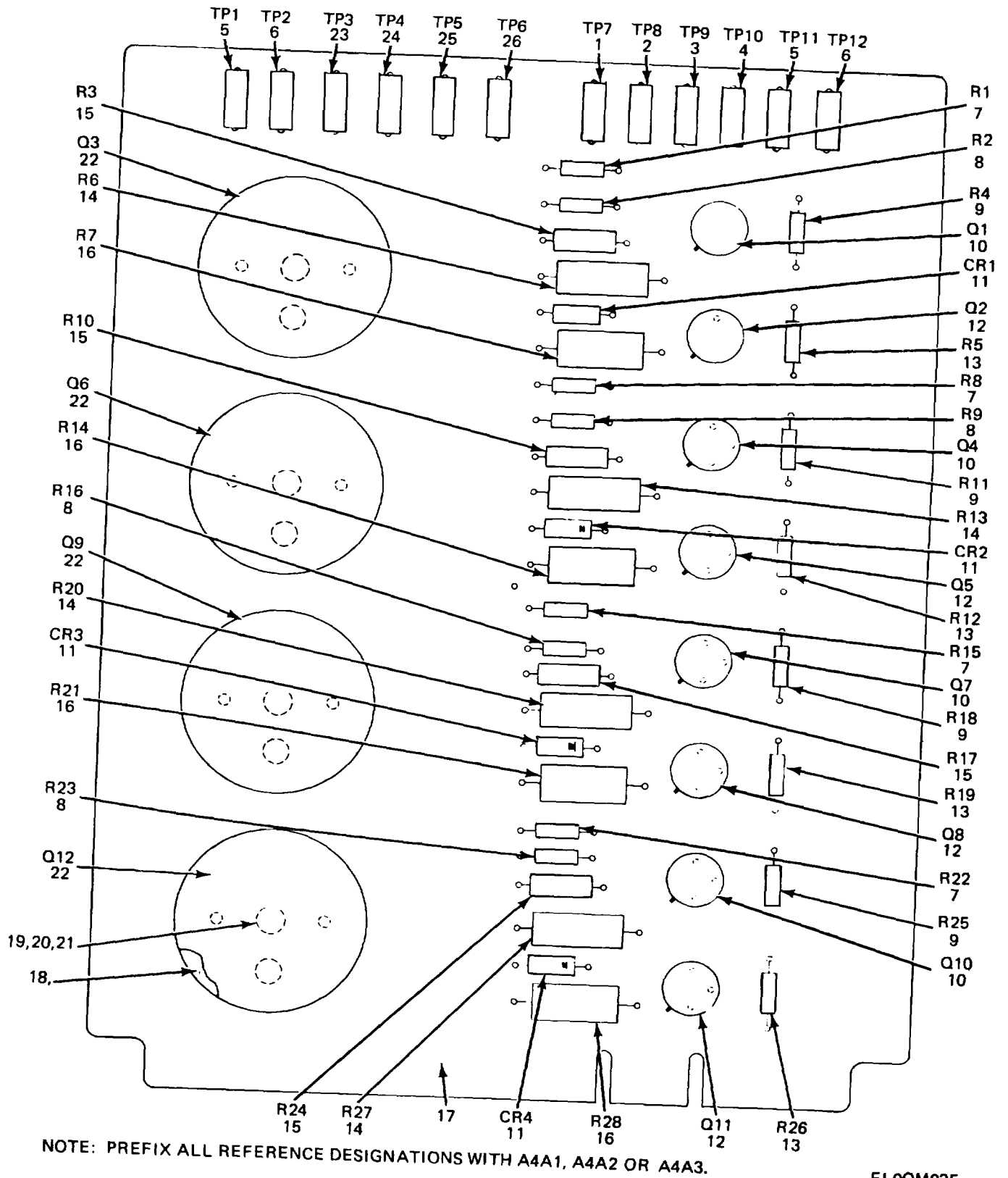

Figure 29. Circuit Card Assembly A4A1.

SECTION II

TM 11-7440-22-40P/NAVELEX 0967-LP-324-0480/TO 31W4-2G-84

(1) ILLUSTRATION		(2)	(3)	(4)	(5)	(6) DESCRIPTION	(7)	(8)
(a) FIG NO.	(b) ITEM NO.	SMR CODE	NATIONAL STOCK NUMBER	PART NUMBER	FSCM	USABLE ON CODE	U/M	QTY INC IN UNIT
						GROUP 040102 CIRCUIT CARD ASSEMBLY A4A1		
29	1	PADZZ	5935-00-868-4192	105-762-10	74970	JACK, TIP	EA	1
29	2	XDDZZ		105-763-10	74970	JACK, TIP	EA	1
29	3	PADZZ	5935-00-089-4856	105-751-10	74970	JACK, TIP	EA	1
29	4	PADZZ	5935-00-690-1742	105-753-10	74970	JACK, TIP	EA	1
29	5	PADZZ	5935-00-868-4188	105-758-10	74970	JACK, TIP	EA	2
29	6	PADZZ	5935-00-115-2273	105-752-10	74970	JACK, TIP	EA	2
29	7	PADZZ	5905-00-805-9714	RC07GF362J	81349	RESISTOR	EA	4
29	8	PADZZ	5905-00-681-6462	RC07GF102J	81349	RESISTOR, FIXED, COMP	EA	4
29	9	PADZZ	5905-00-683-7723	RC07GF152J	81349	RESISTOR, FIXED, COMP	EA	4
29	10	PADZZ	5961-00-949-1440	JAN2N2905A	81349	TRANSISTOR.....	EA	4
29	11	PADZZ	5961-00-814-0768	JAN1N3064	81349	SEMICONDUCTOR DEVIC.....	EA	4
29	12	PADZZ	5961-00-949-1432	JAN2N2219	81349	TRANSISTOR.....	EA	4
29	13	PADZZ	5905-00-683-2238	RC07GF103J	81349	RESISTOR, FIXED, COMP	EA	4
29	14	PADZZ	5905-00-279-2642	RC32GF391J	81349	RESISTOR, FIXED, COMP	EA	4
29	15	PADZZ	5905-00-192-0649	RC020G203J	81349	RESISTOR, FIXED, COMP	EA	
29	16	PADZZ	5905-00-995-7945	RW69V680	81349	RESISTOR, FXED, WIRE	EA	4
29	17	XDDZZ		A53507-001	58189	PRINTED CIRCUIT BD	EA	1
29	18	PADZZ	5999-00-946-0947	10079	07047	MOUNTING PAD, ELECTR.....	EA	4
29	19	PADZZ	5310-00-270-8810	MS35650-104	96906	WASHER.....	EA	4
29	20	PADZZ	5310-00-054-1831	MS35338-81	96906	WASHER.....	EA	4
29	21	PADZZ	5310-00-619-1148	MS15795-808	96906	WASHER, FLAT	EA	4
29	22	PADZZ	5961-00-853-6454	2N1412	81349	TRANSISTOR.....	EA	4
29	23	PADZZ	5935-00-237-1389	105-756-10	74970	JACK, TIP	EA	1
29	24	PADZZ	5935-00-134-5628	105-757-10	74970	JACK, TIP	EA	1
29	25	PADZZ	5935-00-478-7188	105-754-10	74970	JACK, TIP	EA	1
29	26	XDDZZ		105-760-10	74970	JACK, TIP	EA	1

73/(74 blank)

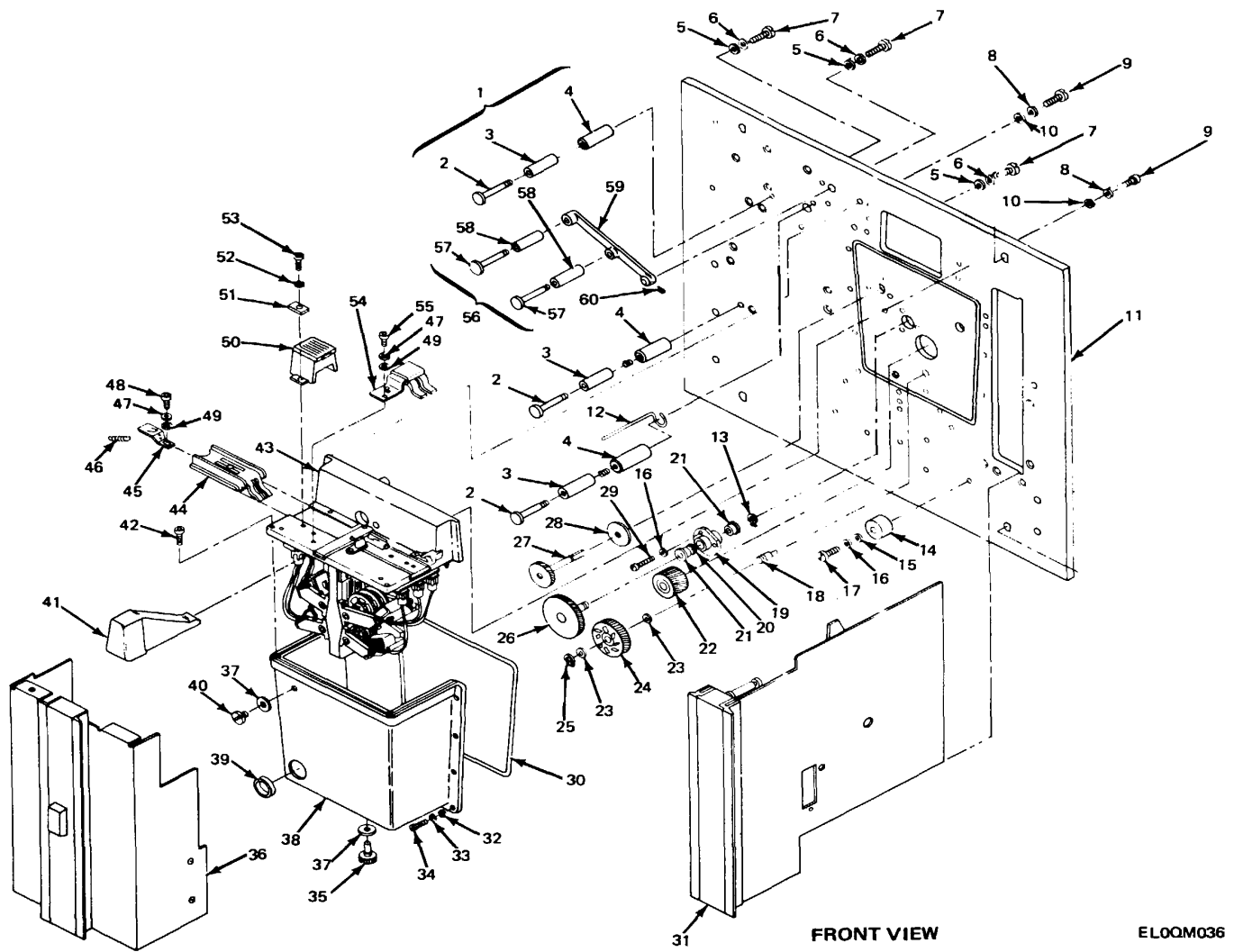
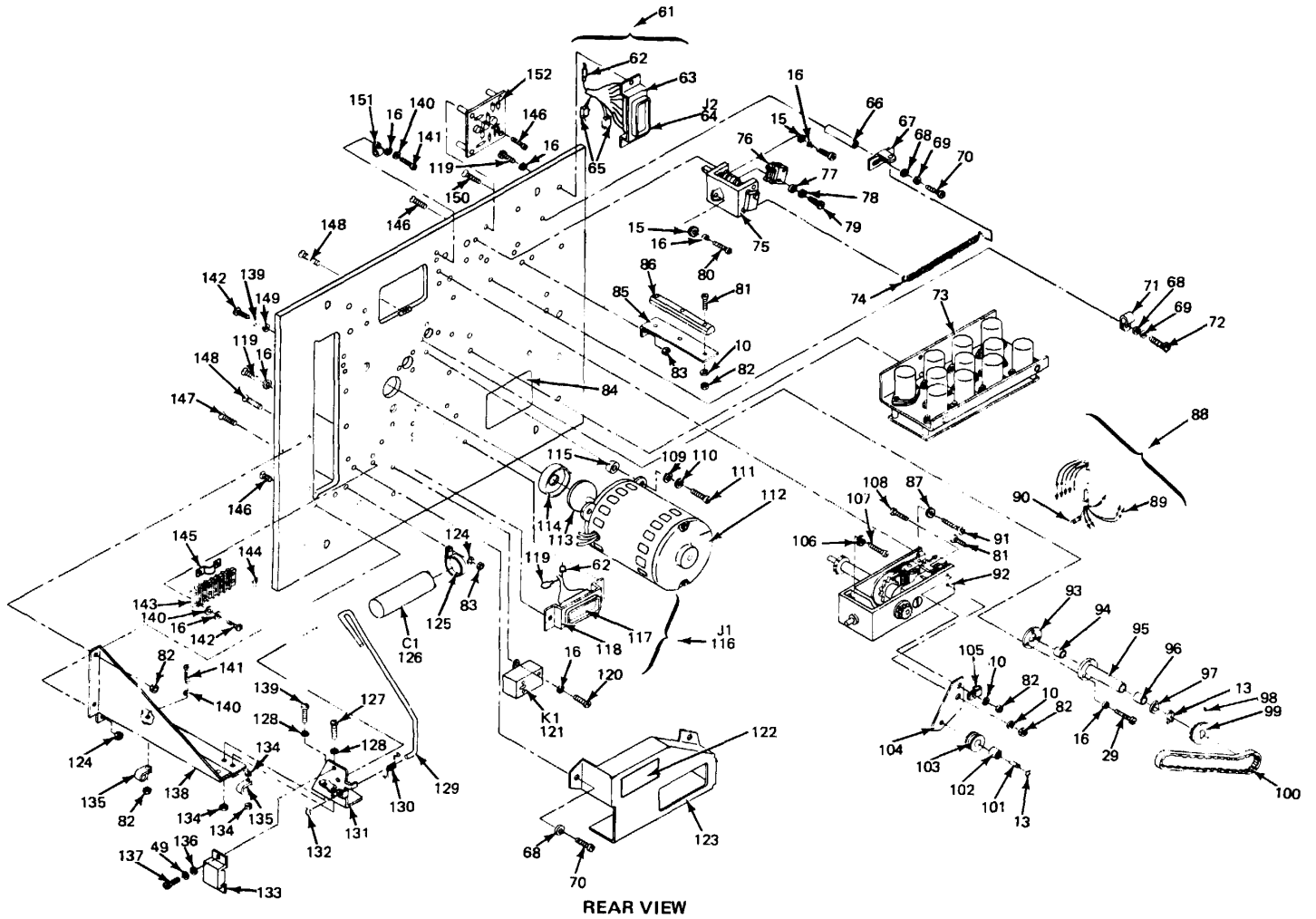

Figure 30. Perforator Assembly (Sheet 1 of 2).



REAR VIEW

NOTE: PREFIX ALL REFERENCE DESIGNATIONS WITH A4

ELOQM037

Figure 30. Perforator Assembly (Sheet 2 of 2)

SECTION II

TM 11-7440-22-40P/NAVELEX 0967-LP-324-0480/TO 31W4-2G-84

(1) ILLUSTRATION		(2)	(3)	(4)	(5)	(6)	(7)	(8)
(a) FIG NO.	(b) ITEM NO.	SMR CODE	NATIONAL STOCK NUMBER	PART NUMBER	FSCM	DESCRIPTION USABLE ON CODE	U/M	QTY INC IN UNIT
						GROUP 0402 PERFORATOR ASSEMBLY		
30	1	XDDDL		333052	12344	ROLLER ASSEMBLY	EA	3
30	2	PADZZ	7040-00-895-3982	304670	12344	PIN, SPECIAL	EA	3
30	3	PADZZ	7040-00-152-0041	345521	12344	ROLLER, TAPE	EA	3
30	4	XDDZZ	7045-00-411-8654	318870	12344	POST, TAPE GUIDE	EA	3
30	5	PADZZ	5310-00-531-9514	AN960C6	88044	WASHER, FLAT	EA	3
30	6	PADZZ	5310-00-616-3555	MS35333-71	96906	WASHER, LOCK	EA	3
30	7	PADZZ	5305-00-054-6654	MS51957-30	96906	SCREW, MACHINE	EA	3
30	8	PADZZ	5310-00-543-2739	MS35333-72	96906	WASHER, LOCK	EA	2
30	9	PADZZ	5305-00-988-7603	MS16995-27	96906	SCREW, CAP, SOCKET HE	EA	5
30	10	PADZZ	5310-00-685-3744	AN960C8	88044	WASHER, FLAT	EA	5
30	11	XDHZZ		378600	12344	PANEL, BLANK	EA	1
30	12	XDHZZ		376700	12344	DEFLECTOR, TAPE	EA	1
30	13	PAHZZ	5365-00-200-5234	5103-25MD	79136	RING, RETAINING	EA	4
30	14	XDHZZ		323221	12344	MAGNET, BUTTON	EA	2
30	15	PAHZZ	5310-00-722-5998	MS15795-805	96906	WASHER, FLAT	EA	1
30	16	PAHZZ	5310-00-616-3555	MS35333-71	96906	WASHER, LOCK	EA	5
30	17	PAHZZ	5305-00-411-0683	MS51957-123	96906	SCREW, MACHINE	EA	1
30	18	PAHZZ	7040-00-056-0092	318790	12344	SHAFT IDLER	EA	1
30	19	PAHZZ	7040-00-053-1316	324980	12344	TUBE BEARING	EA	1
30	20	PAHZZ	5330-00-921-3894	2490	80201	SEAL, PLAIN ENCASED	EA	1
30	21	PAHZZ	3110-00-059-6189	324680	12344	BEARING, BALL ANNULA	EA	2
30	22	PAHZZ	7040-00-898-7021	320950	12344	GEAR, MOTOR SHAFT, MO	EA	1
30	23	XDHZZ		320222	12344	BEARING, WASHER, THRU	EA	2
30	24	PAHZZ	3020-00-053-1430	318841	12344	GEAR ASSEMBLY	EA	1
30	25	PAHZZ	5365-00-663-1245	5103-31MD	79136	RING, RETAINING	EA	1
30	26	PAHZZ	7040-00-895-3995	318840	12344	GEARSHAFT, IDLER	EA	1
30	27	PAHZZ	7040-00-895-3976	318850	12344	GEARSHAFT, MOULDED	EA	1
30	28	PAHZZ	5365-00-178-6045	225375	12344	SHIM	EA	1
30	29	PAHZZ	5305-00-686-5659	4160100	12344	SCREW, SOCKET	EA	6
30	30	PAHZZ	5330-00-191-3934	316500	12344	PACKING, PREFORMED	EA	1
30	31	XDHHH		335571	12344	TAPE SUPPLY ASSY	EA	1
30	32	XDHZZ		4175300	12344	WASHER, FLAT	EA	4
30	33	XDHZZ		4178820	12344	WASHER, LOCK	EA	4
30	34	XDHZZ		4161100	12344	SCREW, MACHINE	EA	1
30	35	XDHZZ		4169600	12344	THUBSCREW	EA	1
30	36	XDHZZ		323230	12344	CHAD BOX ASSEMBLY	EA	1
30	37	PAHZZ	5330-00-686-2322	4177150	12344	PACKING WITH RETAIN	EA	2
30	38	XDHZZ		304993	12344	PAN, OIL	EA	1
30	39	XDHZZ	6680-00-898-721	323241	11234	GAGE SIGHT	EA	1

SECTION II

TM 11-7440-22-40P/NAVELEX 0967-LP-324-0480/TO 31W4-2G-84

(1) ILLUSTRATION		(2)	(3)	(4)	(5)	(6)	(7)	(8)
(a) FIG NO.	(b) ITEM NO.	SMR CODE	NATIONAL STOCK NUMBER	PART NUMBER	FSCM	DESCRIPTION USABLE ON CODE	U/M	QTY INC IN UNIT
30	40	XDHZZ		4169200	12344	SCREW, MACHINE.....	EA	1
30	41	PAHZZ	7035-00-117-0418	601468-1	12344	CHAD CHUTE	EA	1
30	42	PAHZZ	5305-00-483-0222	4156700	12344	SCREW, MACHINE.....	EA	2
30	43	PADDO	7040-00-997-6207	330420	12344	PUNCH, L S MECHANIS.....	EA	1
30	44	PAHZZ	7040-00-054-3440	301100	12344	RETAINER	EA	1
30	45	XHZZ	7040-00-054-3411	300600	11234	LATCH, TAPE RETAINER	EA	1
30	46	PAHZ	5360-00-022-4494	145020	12344	SPRING ACTUATOR	EA	1
30	47	PAHZZ	5310-00-782-1349	AN60C4	88044	WASHER, FLAT	EA	2
30	48	XDHZ		414570	12344	SCREW, MACHINE.....	EA	1
30	49	PAHZZ	5310-00-550-3715	MS35333-70	96906	WASHER, LOCK	EA	2
30	50	PAHDL	7040-00-168-6911	326231	12344	SENSOR ASSEMBLY	EA	1
30	51	PAHZZ	6685-00-989-3615	328990	12344	PLATE, ANEROID ELEME.....	EA	2
30	52	PAHZI	5310-00-933-8118	MS35338-135	96906	WASHER, LOCK	EA	1
30	53	PAHZZ	5305-00-959-0379	MS16995-10	96906	SCREW, CAP, SOCKET HE	EA	1
30	54	XIDHZ	7025-00-497-8797	329361	12344	STRIPPER TAPE ASSM	EA	1
30	55	PAHZZ	5305-00-068-5276	MS16995-9	96906	SCREW, CAP, SOCKET HE	EA	3
30	56	XDHHH		304702	12344	ARM TENSION ASSY	EA	1
30	57	PAHZZ	7040-00-895-3982	304670	12344	PIN, SPECIAL	EA	1
30	58	KXDHZZ	7045-00-411-8654	318870	12344	POST TAPE GUIDE	EA	1
30	59	XOHZZ		304680	12344	ARM, TENSION TAPE	EA	1
30	60	PAHZZ	5305-00-576-7266	MS51021-22	96906	SETSCREW	EA	1
30	61	XDHHH		332320	12344	CONNECTOR ASSEMBLY	EA	1
30	62	PAHZZ	5940-00-793-7286	41663	00779	TERMINAL, TAPER PIN.....	EA	1
30	63	XDHZZ		330621	12344	BRACKET, ELFC CONN.....	EA	1
30	64	PAHZZ	5935-00-931-0386	250-26-16PGDSP	95238	CONNECTOR, ELECTRICA.....	EA	1
30	65	P"A"Z	5930-00-818-7799	11SM23T	91929	SWITCH, SENSITIVE.....	EA	2
30	66	XDHZZ		377230	12344	POST, ANCHOR	EA	1
30	67	XDHZZ		377220	12344	SPRING, ANCHOR	EA	1
30	68	XDHZZ		4175400	12344	WASHER, FLAT	EA	4
30	69	X10HZZ		4179500	12344	WASHER, LOCK	EA	2
30	70	XDHZZ		4164150	12344	SCREW, MACHINE.....	EA	3
30	71	XDHZZ		375330	12344	CLAMP, LOOP	EA	1
30	72	XDHZZ		4164800	12344	SCREW, MACHINE.....	EA	1
30	73	XDHHH		331500	12344	NETORK RC ASSEMBLY	EA	1
30	74	XDHZZ		377270	12344	SPRING.....	EA	1
30	75	XHHH		377030	12344	SENSING ASSEMBLY	EA	1
30	76	PAHIZ	5930-00-929-7869	JS261	91929	ADAPTER, SWITCH ACTU.....	EA	1
30	77	XDHZNZ		4175050	12344	WASHER, FLAT	EA	6
30	78	XOHZZ		4179100	12344	WASHER, LOCK	EA	2
30	79	XDHZZ		4153010	12344	SCREW	EA	2

SECTION II

TM 11-7440-22-40P/NAVELEX 0967-LP-324-0480/TO 31W4-2G-84

(1) ILLUSTRATION		(2)	(3)	(4)	(5)	(6) DESCRIPTION	(7)	(8)
(a) FIG NO.	(b) ITEM NO.	SMR CODE	NATIONAL STOCK NUMBER	PART NUMBER	FSCM	USABLE ON CODE	U/M	QTY INC IN UNIT
30	80	XDHZZ		4160500	12344	SCREW, MACHINE.....	EA	2
30	81	PAHZZ	5305-00-054-6671	MS51957-46	96906	SCREW, MACHINE.....	EA	2
30	82	XDHZZ		4173250	12344	NUT	EA	3
30	83	XDHZZ		4172900	12344	NUT, HEXAGON	EA	4
30	84	XDHZZ		340230	12344	PLATE, IDENT	EA	1
30	85	XDHZZ		376940	12344	BRACKET, MOUNTING	EA	1
30	86	XDHZZ		480065-3	02660	BLOCK, CONNECTOR	EA	1
30	87	XDHZZ		600027-01	12344	WASHER, FLAT	EA	2
30	88	XDHHH		381160	12344	CABLE ASSEMBLY.....	EA	1
30	89	XDHZZ		4018300	12344	PIN TAPER.....	EA	10
30	90	XDHZZ	5940-00-283-5280	88523-06	98410	TERMINAL, LUG	EA	1
30	91	XDHZZ		4165560	12344	SCREW, MACHINE.....	EA	2
30	92	PAHHH	7040-00-134-3774	376631	12344	DRIVE ASSEMBLY, CAPS.....	EA	1
30	93	PAHZZ	5330-00-057-7769	318770	12344	GASKET	EA	1
30	94	PAHZZ	7040-00-895-3994	321370	12344	BUSHING, DRIVE SHAFT.....	EA	1
30	95	PAHZZ	7040-00-053-1317	318760	12344	TUBE BEARING	EA	1
30	96	PAHZZ	6605-00-835-5133	304213	12344	BUSHING, FLANGED	EA	3
30	97	PAHZZ	5310-00-515-7449	AN960C416L	88044	WASHER, FLAT	EA	1
30	98	XDHZZ		4153900	12344	SETSCREW	EA	2
30	99	XDHZZ		220445	12344	PULLEY.....	EA	1
30	100	PAHZZ	3030-00-716-7893	305081	12344	BELT, POSITIVE DRIVE	EA	1
30	101	PAHZZ	7025-00-089-1898	320890	12344	SHAFT, IDLER	EA	1
30	102	PAHZZ	3120-00-936-5450	324741	12344	BUSHING, SLEEVE	EA	1
30	103	PAHZZ	3020-00-926-3753	320900	12344	PULLEY, FLAT	EA	1
30	104	PAHZZ	7040-00-168-6910	320880	12344	BRACKET, IDLER MOUNT.....	EA	1
30	105	XDHZZ	5340-00-782-8737	NAS1397-4	80205	CABLE CLAMP	EA	1
30	106	XDHZZ		600027-02	12344	WASHER, FLAT	EA	2
30	107	PAHZZ		4165375	12344	SCREW, MACHINE.....	EA	2
30	108	PAHZZ	5305-00-054-6672	MS51957-47	96906	SCREW, MACHINE.....	EA	1
30	109	PAHZZ	5310-00-167-0812	AN960C10L	88044	WASHER, FLAT	EA	1
30	110	PAHZZ	5310-00-543-5933	MS35333-73	96906	WASHER, LOCK	EA	3
30	111	PAHZZ	5305-00-983-6654	MS16998-31	96906	SCREW, CAP, SOCKET HE	EA	3
30	112	PAHHH	6105-00-442-6096	SKC19SG34	03494	MOTOR, ALTERNATING C.....	EA	1
30	113	XDHZZ		393950	12344	SPACER, RING.....	EA	1
30	114	PAHZZ	5975-00-878-5833	300030	12344	BOOT, MOTOR.....	EA	1
30	115	XDHZZ		393940	12344	STANDOFF MOTOR.....	EA	3
30	116	XDHHH		332311	12344	CONNECTOR ASSEMBLY	EA	1
30	117	PAHZZ	5935-00-929-3118	EP34PJ	10400	CONNECTOR, ELECTRICA.....	EA	1
30	118	XDHZZ		330620	12344	BRACKET CONNECTOR.....	EA	1
30	119	PAHZZ	5940-00-283-5280	BB523-06	98410	TERMINAL, LUG	EA	1

SECTION II

TM 11-7440-22-40P/NAVELEX 0967-LP-324-0480/TO 31W4-2G-84

(1) ILLUSTRATION		(2)	(3)	(4)	(5)	(6) DESCRIPTION	(7)	(8)
(a) FIG NO.	(b) ITEM NO.	SMR CODE	NATIONAL STOCK NUMBER	PART NUMBER	FSCM	USABLE ON CODE	U/M	QTY INC IN UNIT
30	120	PAHZZ	5305-00-054-6651	MS51957-27	96906	SCREW, MACHINE.....	EA	1
30	121	PAHZZ	5945-00-928-8231	91252-56	80089	RELAY, ARMATURE.....	EA	1
30	122	XDHZZ		332190	12344	PLATE, IDENT	EA	1
30	123	XDHZZ		376720	12344	COVER.....	EA	1
30	124	XDHZZ		PSUA	76055	ADAPTER CONNECTOR.....	EA	1
30	125	PAHZZ	5340-00-576-2157	MS21919DG23	96906	CLAP, CAPACITOR	EA	1
30	126	PAHZZ	5910-00-102-9271	35F489BA	01002	CAPACITOR, FIXED, ELE	EA	1
30	127	PAHZZ	5305-00-054-5652	MS51957-18	96906	SCREW, MACHINE.....	EA	1
30	128	PAHZZ	5310-00-638-9857	AN960C6L	88044	WASHER, FLAT	EA	1
30	129	XDHZZ		338920	12344	ARM TAPE LOW	EA	1
30	130	XDHZZ		352370	12344	SPRING.....	EA	1
30	131	XDHZZ		321440	12344	BRACKT, MTG TAPE.....	EA	1
30	132	PAHZZ	5365-00-282-6297	5555-12MD	79136	RING, RETAINING	EA	7
30	133	PAHZZ	5999-00-982-0036	305110	12344	MAGNET, PERMANENT.....	EA	1
30	134	XDHZZ		4171900	12344	NUT, PLAIN, HEXAGON.....	EA	1
30	135	XDHZZ		4097900	12344	CABLE CLAMP	EA	2
30	136	PAHZZ	5310-00-595-6425	AN960C4L	88044	WASHER, FLAT	EA	1
30	137	PAHZZ	5305-00-054-5644	MS51957-11	96906	SCREW, MACHINE.....	EA	1
30	138	XDHZZ		341820	12344	BRACKET, SLIDE	EA	1
30	139	PAHZZ	5305-00-054-5649	MS51957-15	96906	SCREW, MACHINE.....	EA	1
30	140	PAHZZ	5310-00-531-9514	AN960C6	88044	WASHER, FLAT	EA	1
30	141	PAHZZ	5305-00-054-6652	MS551957-28	96906	SCREW, MACHINE.....	EA	2
30	142	PAHZZ	5305-00-054-6654	MS51957-30	96906	SCREW, MACHINE.....	EA	2
30	143	PAHZZ	5940-00-983-6047	6-140	71785	TERMINAL BOARD.....	EA	1
30	144	PAHZZ	5940-00-283-5280	BB523-06	98410	TERMINAL, LUG	EA	1
30	145	XDHZZ		4110600	12344	JUMPER.....	EA	2
30	146	XDHZZ	5305-00-719-5064	MS51959-30	96906	SCREW, MACHINE.....	EA	3
30	147	PAHZZ	5305-00-764-0064	MS51959-32	96906	SCREW, MACHINE.....	EA	1
30	148	PAHZZ	5305-00-764-0068	MS51959-45	96906	SCREW, MACHINE.....	EA	7
30	149	PAHZZ	5310-00-209-1366	MS35335-58	96906	WASHER, LOCK	EA	1
30	150	XDHZZ		4165500	12344	SCREW, MACHINE.....	EA	1
30	151	XDHZZ		4099080	12344	CLAMP, CABLE	EA	1
30	152	PAHDL	7040-00-898-7036	890050	12344	AMPLIFIER, TMS	EA	1

80/(81 blank)

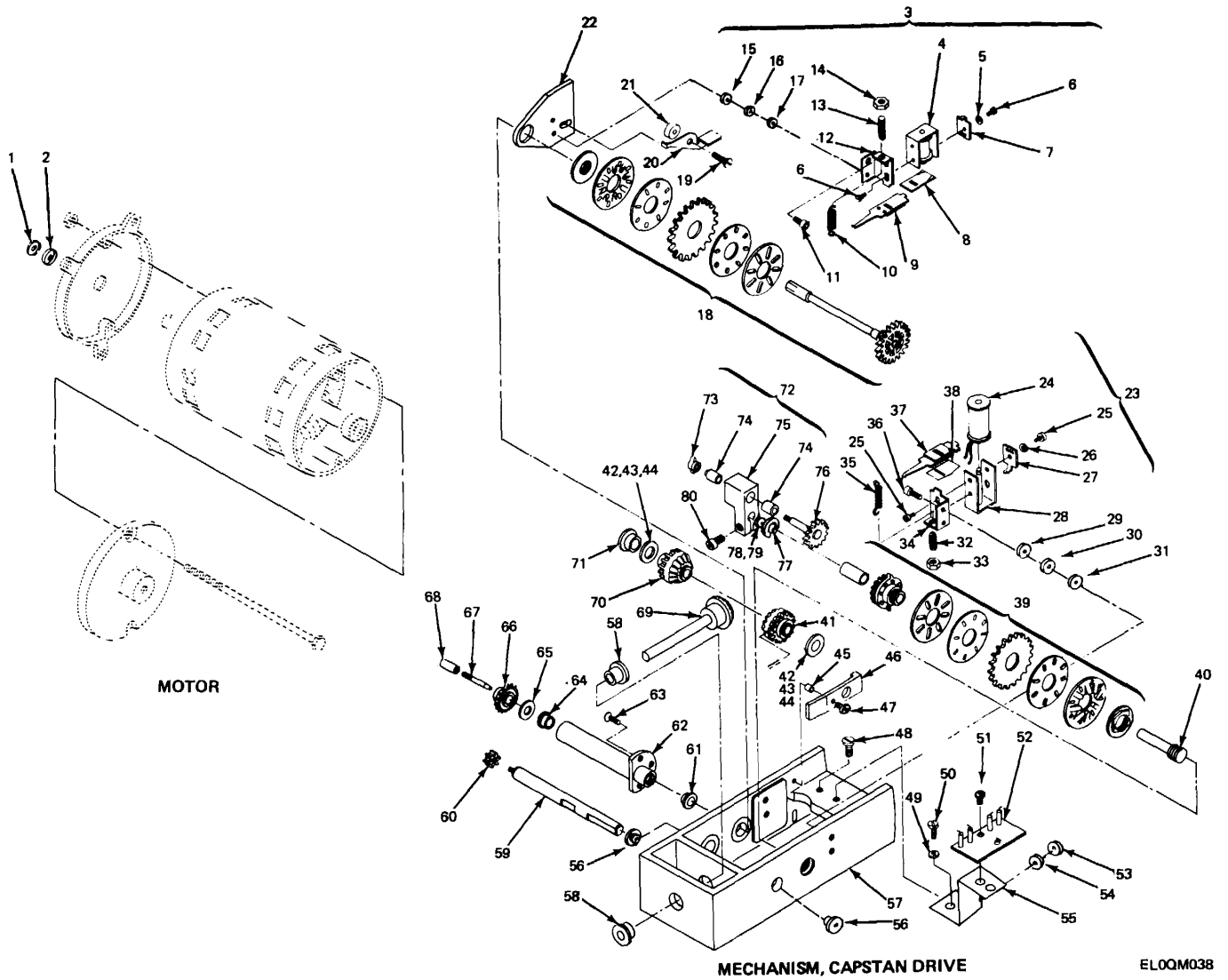

Figure 31. Motor and Mechanism, Capstan Drive.

SECTION II

TM 11-7440-22-40P/NAVELEX 0967-LP-324-0480/TO 31W4-2G-84

(1) ILLUSTRATION		(2)	(3)	(4)	(5)	(6)	(7)	(8)
(a) FIG NO.	(b) ITEM NO.	SMR CODE	NATIONAL STOCK NUMBER	PART NUMBER	FSCM	DESCRIPTION USABLE ON CODE	U/M	QTY INC IN UNIT
						GROUP 040201 MOTOR		
31	1	XDHZZ		3645	80201	OIL SEAL.....	EA	1
31	2	PAHZZ	5330-00-338-1280	38-100137-002	88422	SEAL, OIL.....	EA	1
						GROUP 040202 MECHANISM, CAPSTAN DRIVE		
31	3	PAHHH	7040-00-883-8168	319940	12344	ESCAPEMENT ASSEMBLY.....	EA	1
31	4	PAHZZ	5950-00-057-8140	319950	12344	COIL, RADIO FREQUENC.....	EA	1
31	5	PAHZZ	5310-00-933-8118	MS35338-135	96906	WASHER, LOCK.....	EA	2
31	6	PAHZZ	5305-00-057-0508	MS51958-11	96906	SCREW, MACHINE.....	EA	2
31	7	PAHZZ	7040-00-087-8455	223770	12344	LIMIT, ESCAPEMENT.....	EA	1
31	8	PAHZZ	5365-00-971-6201	226374	12344	SHIM.....	EA	1
31	9	PAHZZ	7040-00-087-8439	318460	12344	ARMATUR, ESCAPEMENT.....	EA	1
31	10	PAHZZ	5360-0-926-5421	300371	12344	SPRING, HELICAL, EXTE.....	EA	1
31	11	PAHZZ	5305-00-188-0219	4153750	12344	SCREW, MACHINE.....	EA	2
31	12	PAHZZ	7040-00-087-8465	313740	12344	BRACKET, ESCAPEMENT.....	EA	1
31	13	PAHZZ	5305-00-601-9080	304370	12344	SCREW, TENSION ADJ.....	EA	1
31	14	XDHZZ		AN365C632	88044	NUT, SLFLKG.....	EA	1
31	15	XDHZZ		305653	12344	SHIM.....	EA	1
31	16	XDHZZ		305652	12344	SHIM.....	EA	1
31	17	XDHZZ	5365-00-235-1003	305651	12344	SHIM, SPECIAL.....	EA	1
31	18	PAHZZ	7025-00-895-4024	301201	12344	CLUTCH, DRIVE MECHAN.....	EA	1
31	19	PAHZZ	5305-00-054-6652	MS51957-28	96906	SCREW, MACHINE.....	EA	1
31	20	PAHHH	7025-00-432-2338	300070	12344	LEVER, ADJUST.....	EA	1
31	21	PAHZZ	5365-00-235-1005	300081	12344	SHIM, SPECIAL.....	EA	1
31	22	XDHZZ	7040-00-455-7662	300280	12344	PLATE, COMPUTER.....	EA	1
31	23	PAHHH	7040-00-989-3621	300172	12344	ACTUATOR ASSEMBLY D.....	EA	1
31	24	PAHZZ	5950-00-134-5811	220534	12344	COIL ASSEMBLY.....	EA	1
31	25	PAHZZ	5305-00-057-0508	MS51958-11	96906	SCREW, MACHINE.....	EA	3
31	26	PAHZZ	5310-00-933-8118	MS35338-135	96906	WASHER, LOCK.....	EA	1
31	27	PAHZZ	7040-00-087-8455	223770	12344	LIMIT, ESCAPEMENT.....	EA	2
31	28	PAHZZ	7040-00-087-8464	223760	12344	FRAME, COIL ASSEMBLY.....	EA	3
31	29	XDHZZ	5365-00-235-1003	305651	12344	SHIM, SPECIAL.....	EA	6
31	30	XDHZZ		305653	12344	SHIM.....	EA	9
31	31	XDHZZ		305652	12344	SHIM.....	EA	6
31	32	PAHZZ	5305-00-601-9080	304370	12344	SCREW, TENSION ADJ.....	EA	2
31	33	XDHZZ		AN365C632	88044	NUT, SELF-LOCKING.....	EA	2
31	34	PAHZZ	7040-00-087-8465	313740	12344	BRACKET, ESCAPEMENT.....	EA	4
31	35	PAHZZ	5360-00-926-5421	300371	12344	SPRING, HELICAL, EXTE.....	EA	2
31	36	XDHZZ		4156400	12344	SREW, MACHINE.....	EA	2
31	37	PAHZZ	7040-00-087-8439	318460	12344	ARMATURE, ESCAPEMENT.....	EA	4
31	38	PAHZZ	5365-00-971-6201	226374	12344	SHIM.....	EA	4

SECTION II

TM 11-7440-22-40P/NAVELEX 0967-LP-324-0480/TO 31W4-2G-84

(1) ILLUSTRATION		(2)	(3)	(4)	(5)	(6) DESCRIPTION	(7)	(8)
(a) FIG NO.	(b) ITEM NO.	SMR CODE	NATIONAL STOCK NUMBER	PART NUMBER	FSCM	USABLE ON CODE	U/M	QTY INC IN UNIT
31	39	PAHZZ	7040-00-895-3992	301810	12344	CLUTCH, CAPSTAIN DRI.....	EA	1
31	40	PAHZZ	7040-00-152-0042	351800	12344	PIVOT, SHAFT CAPSTAN.....	EA	1
31	41	XDHZZ		877683	66059	GEAR ASSY, MOLDED.....	EA	1
31	42	PAHZZ	5365-00-178-6044	225374	12344	SHIM.....	EA	1
31	43	PAHZZ	5365-00-178-6045	225375	12344	SHIM.....	EA	1
31	44	PAHZZ	5365-00-182-6731	225376	12344	SHIM.....	EA	1
31	45	PAHZZ	7040-00-152-0040	340631	12344	SPACER, PLATE ADJUST.....	EA	1
31	46	PAHZZ	7025-00-931-4748	300260	12344	CLAP, ADJUSTING PLA.....	EA	1
31	47	XDHZZ		4160300	12344	SCREW, MACHINE.....	EA	1
31	48	PAHZZ	5305-00-054-6656	MS51957-32	96906	SCREW, MACHINE.....	EA	1
31	49	PAHZZ	5310-00-550-3715	MS35333-70	96906	WASHER, LOCK.....	EA	8
31	50	PAHZZ	5305-00-068-5414	MS16995-11	96906	SCREW, CAP, SOCKET HE.....	EA	1
31	51	PAHZZ	5305-00-054-5648	MS51957-14	96906	SCREW, MACHINE.....	EA	1
31	52	PAHZZ	7025-00-989-3625	833301	12344	ESCAPEMENT.....	EA	1
31	53	XDHZZ		4171900	12344	NUT, PLAIN, HEXAGON.....	EA	6
31	54	PAHZZ	5310-00-782-1349	AN960C4	88044	WASHER, FLAT.....	EA	1
31	55	XDHZZ		396140	12344	BRACKET, CARD MTG.....	EA	1
31	56	PAHZZ	7440-00-168-6908	349840	12344	BUSHING, FLANG.....	EA	2
31	57	XDHZZ		355622	12344	FRAME, CAPSTAN.....	EA	1
31	58	PAHZZ	3120-00-182-8219	349841	12344	BUSHING, SLEEVE.....	EA	2
31	59	PAHZZ	7040-00-160-6906	300780	12344	SHAFT, DRIVE CAPST.....	EA	1
31	60	PAHZZ	3020-00-926-3756	301050	12344	GEAR, SPUR.....	EA	1
31	61	XDHZZ		S6632FCHHMPB	40920	BEARING, BALL.....	EA	1
31	62	PAHZZ	7040-00-172-3638	300511	12344	TUBE, BEARING SUPPOR.....	EA	1
31	63	PAHZZ	5305-00-763-7822	MS51959-14	96906	SCREW, MACHINE.....	EA	7
31	64	XDHZZ		S5632TCHHMPB	40920	BEARING, BALL.....	EA	1
31	65	PAHZZ	5365-00-052-1080	225373	12344	SHIM.....	EA	10
31	66	PAHZZ	3950-00-053-1459	365630	12344	CAPSTAN.....	EA	1
31	67	PAHZZ	5315-00-937-9653	300640	12344	PIN, SPECIAL.....	EA	2
31	68	PAHZZ	7440-00-054-3423	310640	12344	CAP, COLLET PIN.....	EA	2
31	69	PAHZZ	6605-00-987-7679	135511	12344	SHAFT AND GEAR, DRIV.....	EA	1
31	70	XDHZZ		877682	66059	GEAR, CLUSTER, MOLDEOD.....	EA	1
31	71	XDHZZ		18808	71041	BEARING, WASHER, THRU.....	EA	1
31	72	PAHHH	7040-00-455-5797	300890	12344	STEPPING ASSEMBLY, R.....	EA	1
31	73	PAHZZ	7035-00-997-6212	300630	12344	STEPPER, REVERSE.....	EA	1
31	74	PAHZZ	3120-00-842-1363	824-2	71041	BEARING.....	EA	2
31	75	XDHZZ		300500	12344	BRACKET, BEARING.....	EA	1
31	76	PAHZZ	3040-00-019-2370	301160	12344	GEAR.....	EA	1
31	77	PAHZZ	5365-00-282-1633	5133-18MD	79136	RING, RETAINING.....	EA	1
31	78	PAHZZ	5365-00-057-7778	225371	12344	SHIM.....	EA	8

SECTION II

TM 11-7440-22-40P/NAVELEX 0967-LP-324-0480/TO 31W4-2G-84

(1) ILLUSTRATION		(2)	(3)	(4)	(5)	(6)	(7)	(8)
(a) FIG NO.	(b) ITEM NO.	SMR CODE	NATIONAL STOCK NUMBER	PART NUMBER	FSCM	DESCRIPTION USABLE ON CODE	U/M	QTY INC IN UNIT
31	79	PAHZZ	5365-00-178-6043	225372	12344	SHIME	EA	8
31	80	PAHZZ	5305-00-988-7602	MS16995-26	96906	SCREW, CAP, SOCKET HE	EA	5

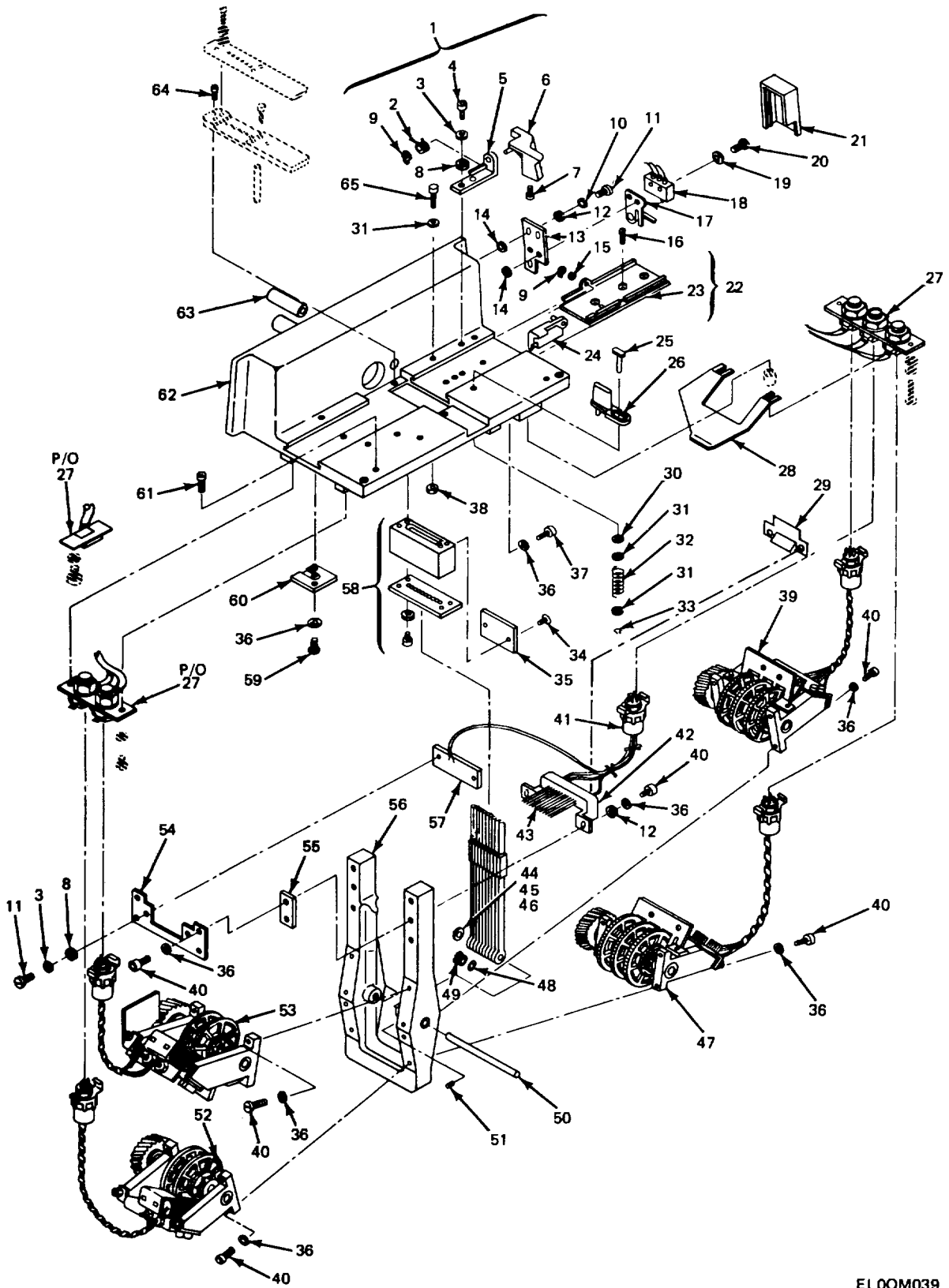

ELOQM039

Figure 32. Mechanism, Punch

SECTION II

TM 11-7440-22-40P/NAVELEX 0967-LP-324-0480/TO 31W4-2G-84

(1) ILLUSTRATION		(2)	(3)	(4)	(5)	(6) DESCRIPTION	(7)	(8)
(a) FIG NO.	(b) ITEM NO.	SMR CODE	NATIONAL STOCK NUMBER	PART NUMBER	FSCM	USABLE ON CODE	U/M	QTY INC IN UNIT
GROUP 040203 MECHANISM, PUNCH								
32	1	XDDDL		331860	12344	BRACKET, LEVER ASSY	EA	1
32	2	XDDZZ		LC022C3	84830	SPRING, HELICAL, COMP	EA	1
32	3	PADZZ	5311-00-933-8118	MS35338-135	96906	WASHR, LOCK	EA	2
32	4	PADZZ	5305-00-959-0379	MS16995-10	96906	SCREW, CAP, SOCKET HE	EA	1
32	5	XDDZZ	5340-00-997-6221	329990	12344	BRACKET, ANGLE.....	EA	1
32	6	XDDZZ	7440-00-989-3605	329980	12344	LEVER, TAP HOLD DOW	EA	1
32	7	XDDZZ		304260	12344	SCREW, MACHINE.....	EA	1
32	8	XDDZZ	5310-00-595-6211	MS15795-803	96906	WASHER, FLAT	EA	2
32	9	PADZZ	5365-00-957-7776	5555G9MD	79136	RING, RETAINING	EA	2
32	10	PADZZ	5310-00-550-3715	MS35333-70	96906	WASHER, LOCK	EA	1
32	11	PADZZ	5305-00-068-5414	MS16995-11	96906	SCEW, CAP, SOCKET HE.....	EA	2
32	12	PADZZ	5310-00-531-9514	AN960C6	88044	WASHER, FLAT	EA	3
32	13	XDDZZ		330000	12344	PLATE, MOUNTING.....	EA	1
32	14	XDDZZ		330230	12344	SPACER, MOUNTING	EA	3
32	15	XODZZ		4179210	12344	WASHER, SPRING	EA	1
32	16	XDDZZ		4153800	12344	SCREW, SPECIAL	EA	2
32	17	PADZZ	5930-00-932-3586	333610	12344	ADAPTER, SWITCH ACTU.....	EA	1
32	18	PADZZ	5930-00-951-6451	3SX1T	91929	SWITCH, SENSITIVE.....	EA	1
32	19	PADZZ	5310-00-928-2690	MS35338-134	96906	WASHER, LOCK	EA	1
32	20	PADZZ	5305-00-054-5638	MS51957-4	96906	SCREW, MACHINE.....	EA	2
32	21	XDDZZ		330010	12344	COVER, SWITCH.....	EA	1
32	22	PADDL	7025-00-497-8788	331850	12344	TAPE GUIDE ASSEMBLY.....	EA	1
32	23	PADZZ	7040-00-019-3017	329930	12344	INSERT GUIDANCE.....	EA	1
32	24	PADZZ	7040-00-851-5113	330160	12344	LEVER NARROW TAPE G	EA	1
32	25	PADZZ	7025-00-895-4053	330190	12344	PIVOT, TAPE ARM.....	EA	1
32	26	PADZZ	7040-00-898-7160	324960	12344	ARM, TAPE WIDTH	EA	1
32	27	XDDDL		331840	12344	CABLE ASSY, MECH.....	EA	1
32	28	XDDZZ		332010	12344	BAFFLE CONTROL.....	EA	1
32	29	XDDZZ		01-003337-001	06809	SPLASH GUARD	EA	1
32	30	PADZZ	5330-00-990-2869	333550	12344	GASKET	EA	1
32	31	PADZZ	5310-00-595-6211	MS15795-303	96906	WASHER, FLAT	EA	3
32	32	XDDZZ		4094415	12344	SPRING, HELICAL, COMP	EA	1
32	33	PADZZ	5365-00-064-6279	MS90707-4009	96906	RING, RETANING	EA	1
32	34	PADZZ	5305-00-764-2966	MS51959-2	96906	SCREW, MACHINE.....	EA	1
32	35	XDDZZ		01-003336-001	06809	COVER, PLATE	EA	1
32	36	PADZZ	5310-00-616-3555	MS35333-71	96906	WASHER, LOCK	EA	5
32	37	PADZZ	5305-00-959-1082	MS16995-18	96906	SCREW, CAP, SOCKET HE	EA	1
32	38	PADZZ	5310-00-836-3520	511-041800-00	78189	NUT, PLAIN, ASSEMBLED.....	EA	1
32	39	XDHDL		329880	12344	BANK, CLUTCH, UPR R	EA	1

SECTION II

TM 11-7440-22-40P/NAVELEX 0967-LP-324-0480/TO 31W4-2G-84

(1) ILLUSTRATION		(2)	(3)	(4)	(5)	(6) DESCRIPTION	(7)	(8)
(a) FIG NO.	(b) ITEM NO.	SMR CODE	NATIONAL STOCK NUMBER	PART NUMBER	FSCM	USABLE ON CODE	U/M	QTY INC IN UNIT
32	40	PADZZ	5305-00-959-0382	MS16995-17	96906	SCREW, CAP, SOCKET, HE	EA	4
32	41	PADZZ	7040-00-168-6912	329790	12344	CONTACT ASSEMBLY.....	EA	1
32	42	PADZZ	5935-0-913-0925	10PLSH19	81312	CONNECTOR, PLUG, ELEC	EA	1
32	43	PADZZ	7025-00-895-4092	325611	12344	CONTACT FIXED BIT E.....	EA	1
32	44	PADZZ	5365-00-686-5925	309792	12344	SHIM.....	EA	1
32	45	PADZZ	5365-00-686-5918	309791	12344	SHIM.....	EA	1
32	46	PADZZ	5365-00-686-5911	309790	12344	SHIM.....	EA	1
32	47	PAHDL	7040-00-019-2248	329881	11234	BANK, CLUTCH	EA	1
32	48	PADZZ	5365-00-980-8163	365600	12344	SHIM.....	EA	1
32	49	PADZZ	7040-00-898-7020	300410	12344	GEAR, PUNCH DRIVE.....	EA	1
32	50	PADZZ	7040-00-898-7103	300760	12344	SHAFT, PIVOT, POLISHE.....	EA	1
32	51	PADZZ	5305-00-717-6951	MS571963-3	96906	SETSCREW	EA	1
32	52	PAHDL	7040-00-019-2225	329891	12344	BANK, CLUTCH	EA	1
32	53	PAHDL	7040-00-019-2247	329890	12344	BANK, CLUTCH	EA	1
32	54	PADZZ	7035-00-472-3997	300580	12344	BRACKET, FIXED CONTA.....	EA	1
32	55	PADZZ	7040-00-056-0164	301040	12344	SPACER.....	EA	2
32	56	XDDZZ		325330	12344	FRAME, MAIN	EA	1
32	57	PADZZ	7025-00-895-4044	325340	12344	CONTACT SENSING MOV	EA	1
32	58	PAHDL	7040-00-019-2949	325480	12344	HEAD PUNCH ASSY	EA	1
32	59	PADZZ	5305-00-054-6650	MS51957-26	96906	SCREW, MACHINE.....	EA	1
32	60	XDDZZ		319890	12344	PLATE OIL CHAMER.....	EA	1
32	61	XDDZZ		304920	12344	SCREW, HINGE	EA	2
32	62	PADZZ	7040-00-310-0884	300362	12344	DECK, TAPE	EA	1
32	63	PADZZ	7040-00-056-0135	307460	12344	BUSHING	EA	1
32	64	XDDZZ		4154225	12344	SCREW, MACHINE.....	EA	1
32	65	XDDZZ		4156775	12344	SCREW, MACHINE.....	EA	1

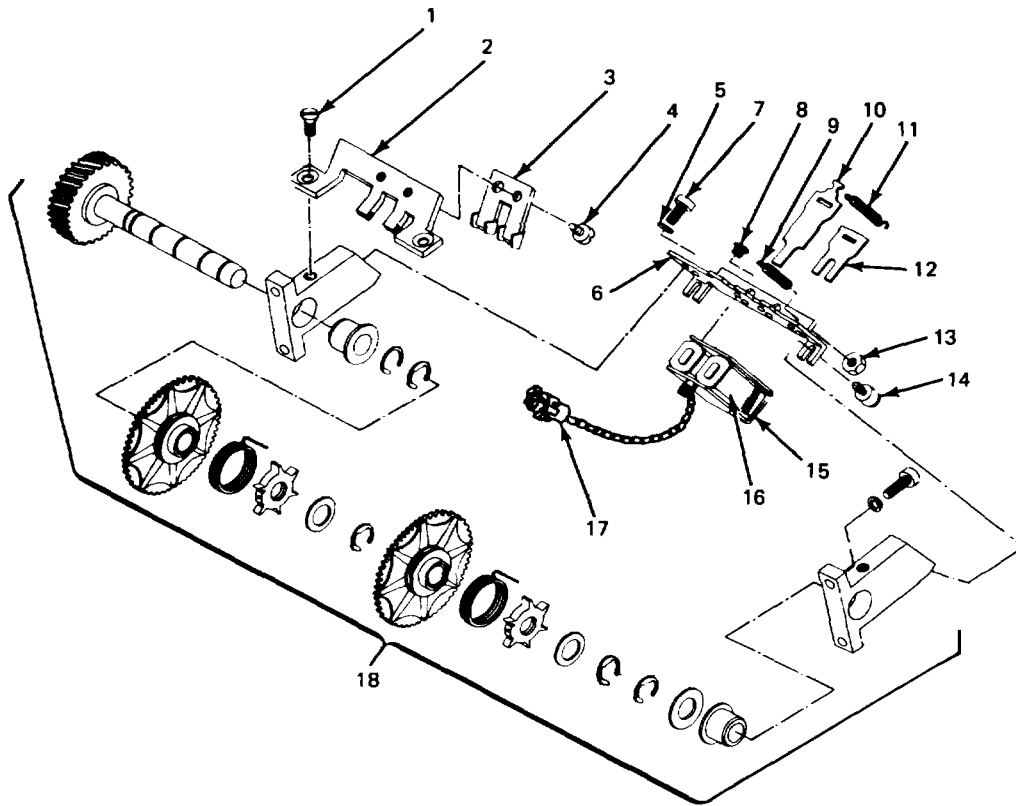

LOWER LEFT BANK CLUTCH

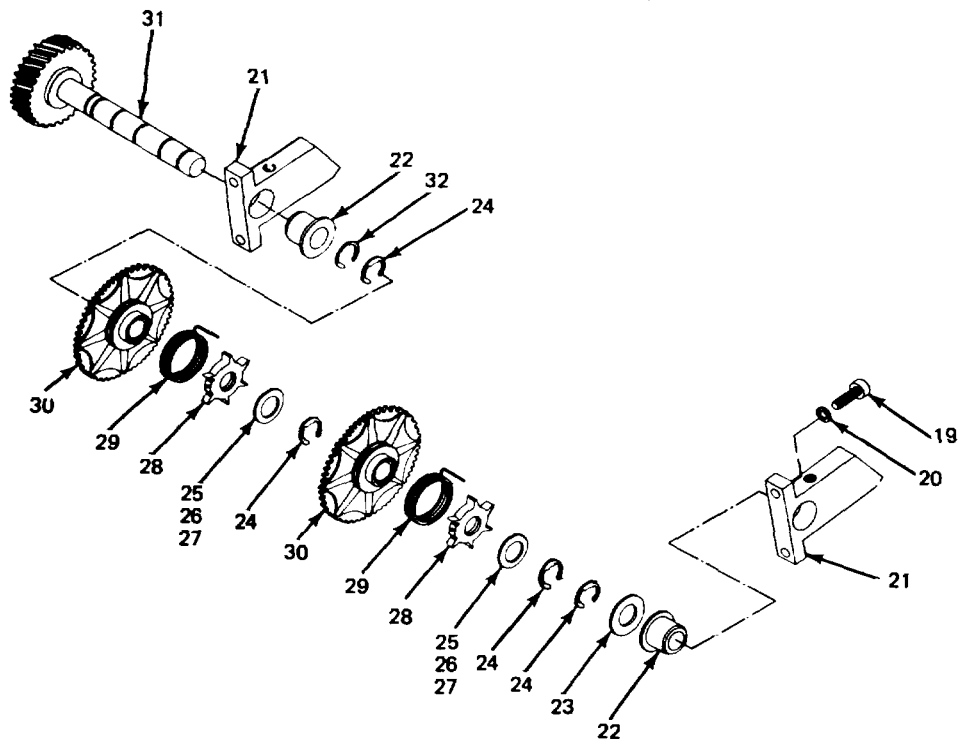

CLUTCH AND SLEEVE ASSY.

ELOQM040

Figure 33. Bank Clutch, Lower Left and Clutch and Sleeve Assembly.

SECTION II

TM 11-7440-222-40P/NAVELEX 0967-LP-324-0480/TO 31W4-2G-84

(1) ILLUSTRATION		(2)	(3)	(4)	(5)	(6)	(7)	(8)
(a) FIG NO.	(b) ITEM NO.	SMR CODE	NATIONAL STOCK NUMBER	PART NUMBER	FSCM	DESCRIPTION USABLE ON CODE	U/M	QTY INC IN UNIT
						GROUP 04020301 BANK CLUTCH,LOWER LEFT		
33	1	PADZZ	5305-00-770-2533	MS51959-13	96906	SCREW,MACHINE.....	EA	2
33	2	XDOZZ		3007112	12344	BRACKET EQUIPMENT.....	EA	1
33	3	PADZZ	700-00-054-3415	300722	12344	ARMATURE.....	EA	1
33	4	PADZZ	5305-00-054-5644	MS51957-11	96906	SCREW,MACHINE.....	EA	1
33	5	PADZZ	5310-00-616-3555	MS135333-71	96906	WASHER,LOCK.....	EA	1
33	6	XDOZZ		300661	12344	BRACKET,CONTROL.....	EA	1
33	7	PADZZ	5305-00-051-6751	MS16995-16	96906	SCREW,CAP,SOCKET.....	EA	1
33	8	PADZZ	5305-00-057-0508	MS51958-11	96906	SCREW,MACHINE.....	EA	1
33	9	PADZZ	5305-00-601-9080	304370	12344	SCREW,TENSION ADJ.....	EA	1
33	10	PADZZ	7004-00-054-3412	300480	12344	LATCH,ARMATURE.....	EA	1
33	11	PADZZ	5360-00-926-5421	300371	12344	SPRING,HELICAL,EXTE.....	EA	1
33	12	PADZZ	5340-00-971-7610	30090	12344	SHIM,ANTI RESID.....	EA	1
33	13	XDDZZ		AN365C632	88044	NUT,SELF-LOCKING.....	EA	1
33	14	XDDZZ		305300	12344	SCREW,SPECIAL.....	EA	1
33	15	PAHDL	7040-00-019-3067	327221	12344	COIL ASSEMBLY,ELECT.....	EA	1
33	16	XDOZZ		332833	12344	COIL,RADIO FREQUENC.....	EA	1
33	17	XDDZZ		M4PLSH9	81312	CONNECTOR.....	EA	1
33	18	PADDL	7040-00-121-9078	306150	12344	CLUTCH AND SLEEVE ASSY.....	EA	1
						GROUP 0402030101 CLUTCH AND SLEEVE ASSEMBLY		
33	19	PADZZ	5305-00-763-7822	MS51959-14	96906	SCREW,MACHINE.....	EA	2
33	20	PADZZ	5310-00-616-3555	MS35333-71	96906	WASHER,LOCK.....	EA	2
33	21	PADZZ	7025-00-089-9386	300730	12344	BRACKET,BEARING.....	EA	2
33	22	PADZZ	7040-00-056-0133	308950	12344	BUSHING.....	EA	2
33	23	XDDZZ		18I80	71041	BEARING,WASHER,THRU.....	EA	1
33	24	PADZZ	5365-00-721-7680	5133-25KD	79136	RING,RETAINING.....	EA	4
33	25	PADZZ	5365-00-178-6044	225374	12344	SHIM.....	EA	1
33	26	PADZZ	5365-00-178-6045	225375	12344	SHIM.....	EA	1
33	27	PADZZ	5365-00-182-6731	225376	12344	SHIM.....	EA	1
33	28	PADZZ	7040-00-053-1321	30030	12344	CONTROL SLEEVE.....	EA	2
33	29	XDDZZ	5360-00-172-6468	358950	12341	SPRING,COMP.....	EA	2
33	30	XDDZZ		300400	12344	SPRING ASSEMBLY.....	EA	2
33	31	PADZZ	7040-00-054-3430	322701	12344	SHAFT,CLUTCH.....	EA	1
33	32	PADZZ	5365-00-845-0286	MS16632-4031	96906	RING,RETAINING.....	EA	1
					91			

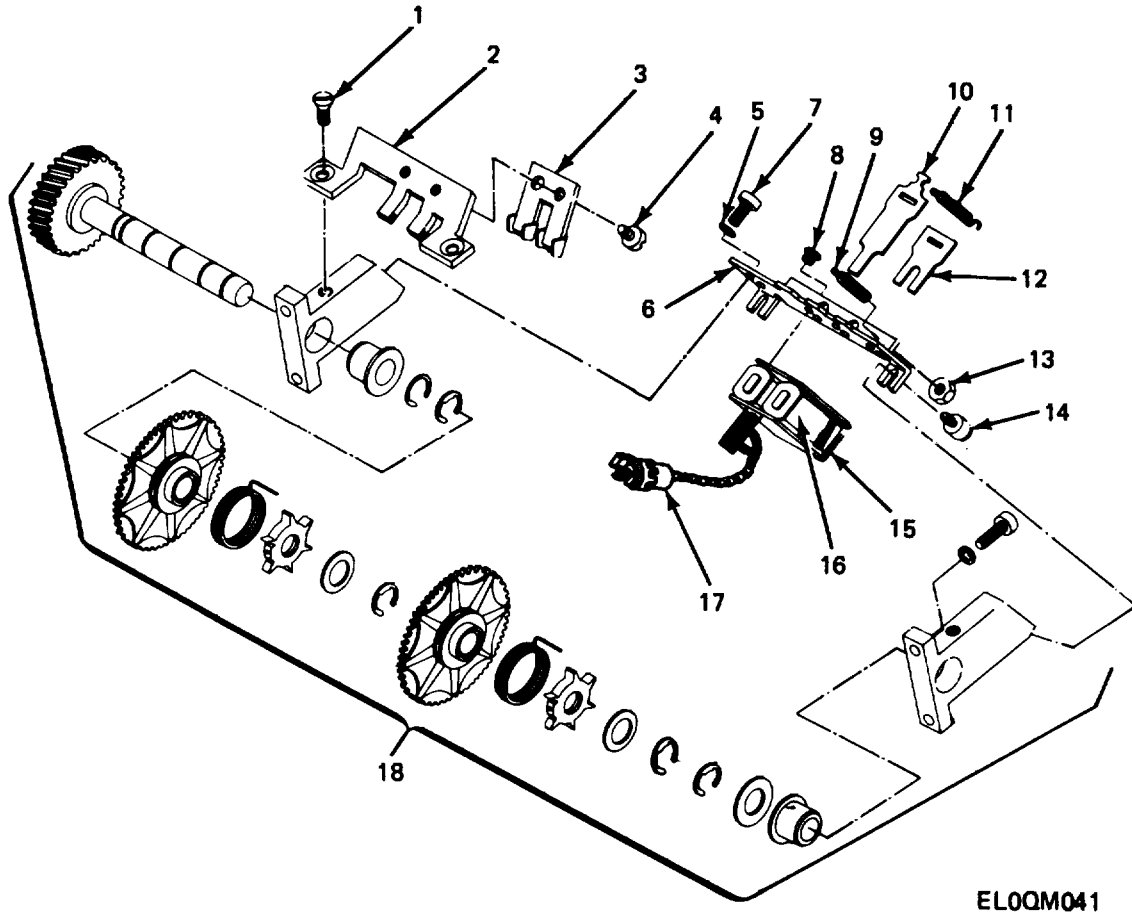

ELOQM041

Figure 34. Bank Clutch, Upper Left.

SECTION II

TM 11-7440-222-40P/NAVELEX 0967-LP-324-0480/TO 31W4-2G-84

(1) ILLUSTRATION		(2)	(3)	(4)	(5)	(6) DESCRIPTION	(7)	(8)
(a) FIG NO.	(b) ITEM NO.	SMR CODE	NATIONAL STOCK NUMBER	PART NUMBER	FSCM	USABLE ON CODE	U/M	QTY INC IN UNIT
						GROUP 04020302 BANK CLUTCH,UPPER LEFT		
34	1	PADZZ	5305-00-770-2533	MS51959-13	96906	SCREW,MACHINE.....	EA	1
34	2	XDDZZ		300713	12344	BRACKET,CONTROL.....	EA	1
34	3	PADZZ	7040-00-054-3415	300722	12344	ARMATURE.....	EA	1
34	4	PADZZ	5305-00-054-5635	MS51957-1	96906	SCREW,MACHINE.....	EA	1
34	5	PADZZ	5310-00-616-3555	MS35333-71	96906	WASHER,LOCK.....	EA	1
34	6	XDDZZ		300662	12344	BRACKET,CONTROL.....	EA	1
34	7	PADZZ	5305-00-051-6751	MS16995-16	96906	SCREW,CAP,SOCKET HE.....	EA	1
34	8	PADZZ	5305-00-057-0508	MS51958-11	96906	SCREW,MACHINE.....	EA	1
34	9	PADZZ	5305-0601-9080	304370	12344	SCREW,TENSION ADJ.....	EA	1
34	10	PADZZ	7040-00-054-3412	300480	2344	LATCH,ARMATURE.....	EA	1
34	11	PADZZ	5360-00-926-5421	300371	12344	SPRING,HELICAL,XTE.....	EA	1
34	12	PADZZ	5340-00-971-7610	300940	12344	SHIM,ANTI RESID.....	EA	1
34	13	XDDZZ		AN365C632	88044	NUT,SELF-LOCKING.....	EA	1
34	14	XDDZZ		305300	12344	SCREW,SPECIAL.....	EA	1
34	15	PADDL	7040-00-019-3055	327220	12344	COIL ASSEMBLY,ELECT.....	EA	1
34	16	XDDZZ		332833	12344	COIL,RADIO FREQUENC.....	EA	1
34	17	XDDZZ		M4PLSH9	81312	CONNECTOR.....	EA	1
34	18	PADDL	7040-00-121-9078	306150	12344	CLUTCH AND SLEEVE ASSY FOR.....	EA	1
						BREAKDOWN SEE FIG.33		
					93			

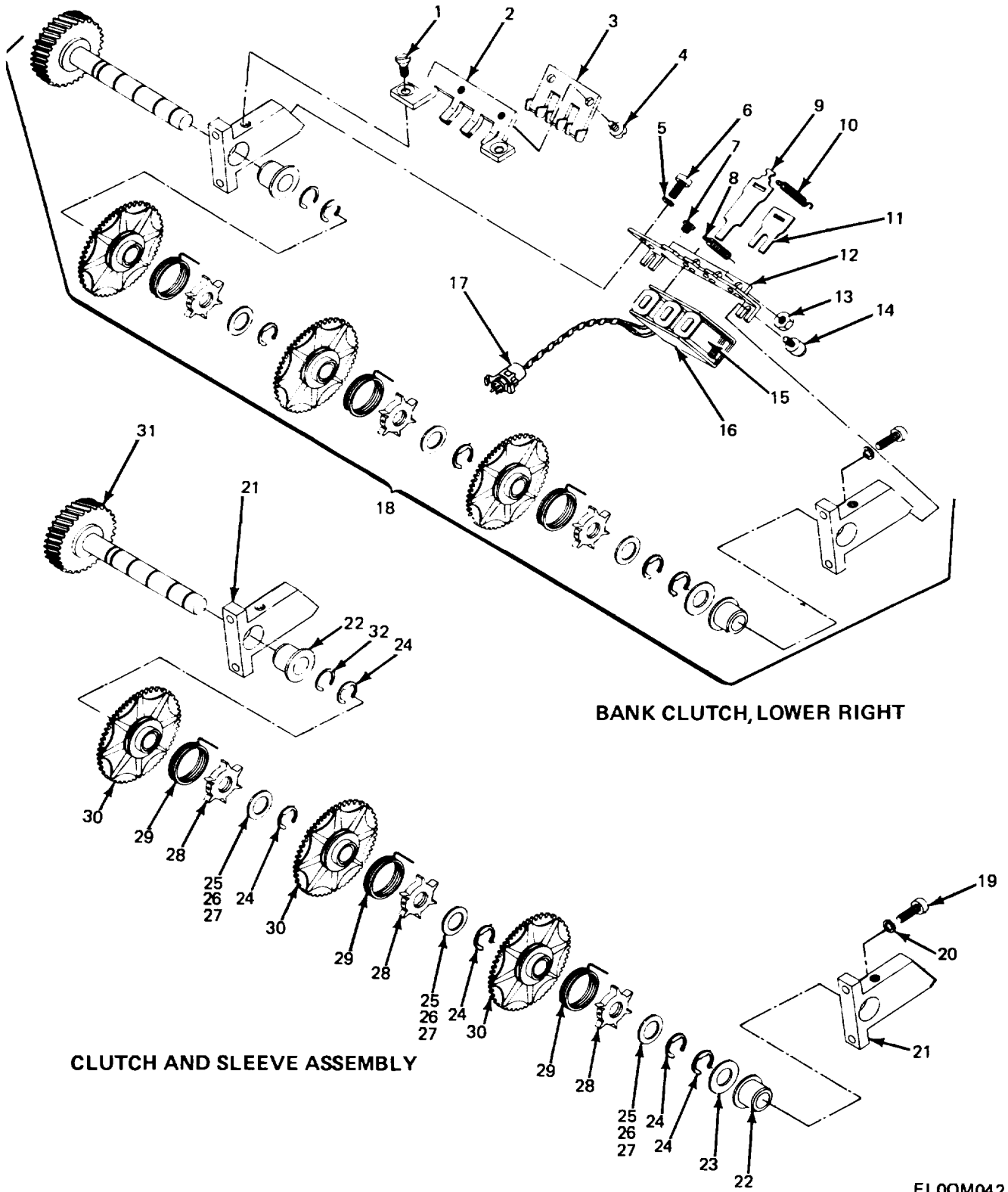
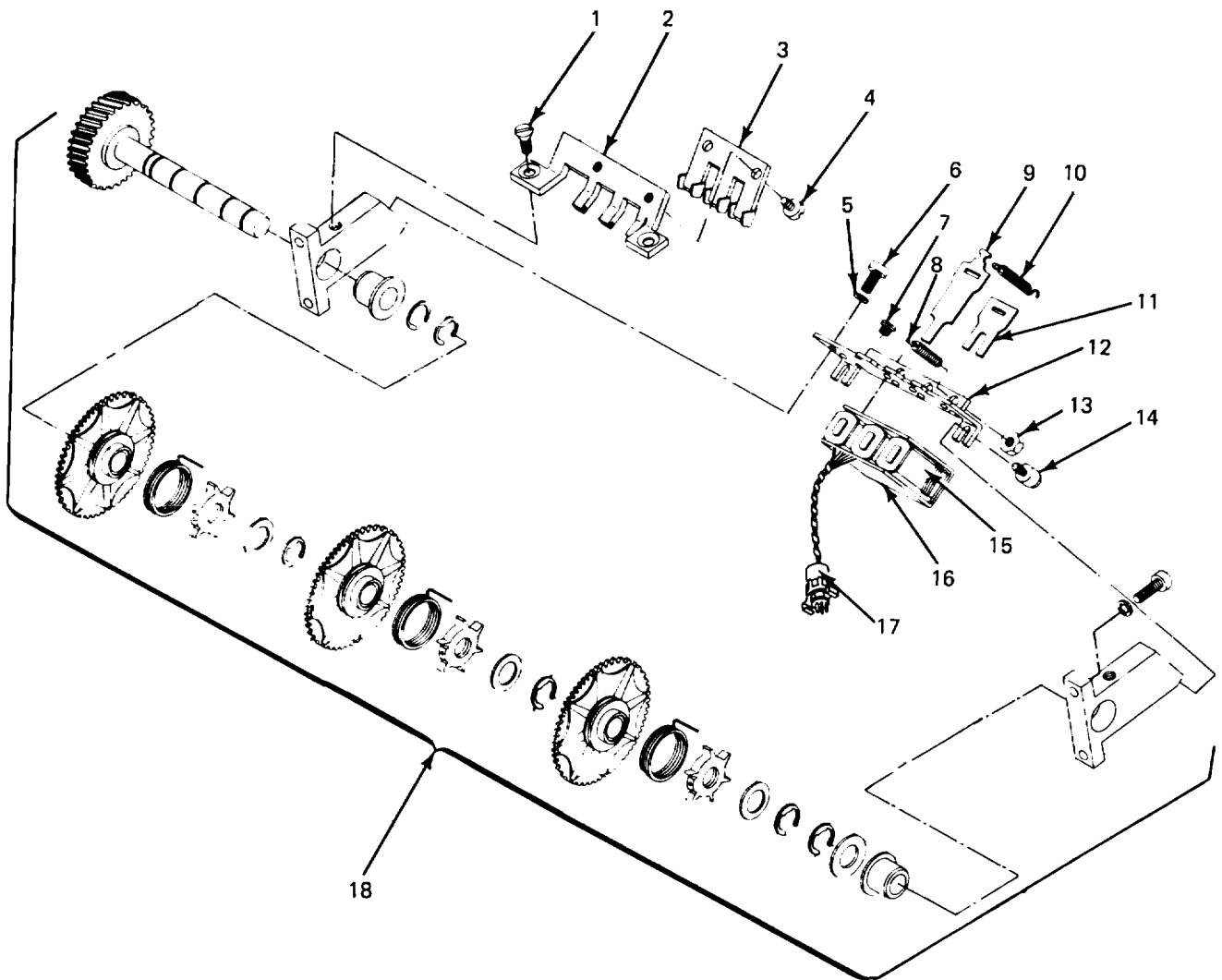

Figure 35. Bank Clutch, Lower Right and Clutch and Sleeve Assembly.

SECTION II

TM 11-7440-222-40P/NAVELEX 0967-LP-324-0480/TO 31W4-2G-84

(1) ILLUSTRATION		(2)	(3)	(4)	(5)	(6)	(7)	(8)
(a) FIG NO.	(b) ITEM NO.	SMR CODE	NATIONAL STOCK NUMBER	PART NUMBER	FSCM	DESCRIPTION USABLE ON CODE	U/M	QTY INC IN UNIT
						GROUP 04020303 BANK CLUTCH,LOWER RIGHT		
35	1	PADZZ	5305-00-770-2533	MS51959-13	96906	SCREW,MACHINE.....	EA	2
35	2	XDDZZ		300711	12344	BRACKET,CONTROL.....	EA	1
35	3	PADZZ	7035-00-054-3414	3001721	12344	ARMATURE.....	EA	1
35	4	PADZZ	5305-00-054-5644	M5S51957-11	96906	SCREW,MACHINE.....	EA	1
35	5	PADZZ	5310-00-616-3555	M535333-71	96906	WASHER,LOCK.....	EA	1
35	6	PADZZ	5305-00-051-6751	MS16995-16	96906	SCREW,CAP,SOCKET.....	EA	1
35	7	PADZZ	5305-00-057-0508	MS51958-11	96906	SCREW,MACHINE.....	EA	1
35	8	PADZZ	5305-00-601-9080	304370	12344	SCREW,TENSION ADJ.....	EA	1
35	9	PADZZ	7040-00-054-3412	300480	12344	LATCH,ARMATURE.....	EA	1
35	10	PADZZ	5360-00-926-5421	300371	12344	SPRING,HELICAL,EXTE.....	EA	1
35	11	PADZZ	5340-00-971-7610	300940	12344	SHIM,ANTI RESID.....	EA	1
35	12	XDDZZ		300650	12344	BRACKET,CONTROL.....	EA	1
35	13	XDDZZ		AN365C632	88044	NUT,SELF-LOCKING.....	EA	1
35	14	XDDZZ		305300	12344	SCREW,SPECIAL.....	EA	1
35	15	XDDZZ		332843	12344	COIL AND FRAME.....	EA	1
35	16	PAHDL	7040-00-019-3053	329871	12344	COIL ASSEMBLY ELEC.....	EA	1
35	17	XDDZZ	5935-00-905-5738	M7PLSH9	81312	CONNECTOR,PLUG,ELEC.....	EA	1
35	18	PADDL	7040-00-121-9078	306150	12344	CLUTCH AND SLEEVE ASSY.....	EA	1
						GROUP 0402030301 CLUTCH AND SLEEVE ASSEMBLY		
35	19	PADZZ	5305-00-959-0382	MS16995-17	96906	SCREW,CAP,SOCKET,HE.....	EA	2
35	20	PADZZ	5310-00-616-3555	MS355333-71	96906	WASHER,LOCK.....	EA	2
35	21	PADZZ	7025-00-089-9386	300730	12344	BRACKET,BEARING.....	EA	2
35	22	PADZZ	7040-00-056-0133	308950	12344	BUSHING.....	EA	1
35	23	XDDZZ		18808	71041	BEARING,WASHER,THRU.....	EA	1
35	24	PADZZ	5365-00-721-7680	5133-25M0	79136	RING,RETAINING.....	EA	6
35	25	PADZZ	5365-00-178-6044	225374	12344	SHIM.....	EA	1
35	26	PADZZ	5365-00-178-6045	225375	12344	SHIM.....	EA	1
35	27	PADZZ	5365-00-182-6731	225376	12344	SHIM.....	EA	1
35	28	PADZZ	7040-00-053-1321	300430	12344	CONTROL SLEEVE.....	EA	3
35	29	XDDZZ	5360-00-172-6468	358950	12344	SPRING,COMP.....	EA	3
35	30	XDDZZ		300400	12344	SPRING ASSEMBLY.....	EA	3
35	31	PADZZ	7040-00-054-3429	322700	12344	SHAFT,CLUTCH.....	EA	1
35	32	PADZZ	5365-00-845-0286	MS16632-4031	96906	RING,RETAINING.....	EA	1
					95			



ELOQM043

Figure 36. Bank Clutch, Upper Right.

SECTION II

(1) ILLUSTRATION		(2)	(3)	(4)	(5)	(6)	(7)	(8)
(a) FIG NO.	(b) ITEM NO.	SMR CODE	NATIONAL STOCK NUMBER	PART NUMBER	FSCM	DESCRIPTION USABLE ON CODE	U/M	QTY INC IN UNIT
						GROUP 04020304 BANK CLUTCH, UPPER RIGHT		
36	1	PADZZ	5305-00-770-2533	MS51959-13	96906	SCREW,MACHINE.....	EA	1
36	2	XDDZZ		325350	12344	BRACKET,SPRING.....	EA	1
36	3	PADZZ	7035-00-054-3414	300721	112344	ARMATURE.....	EA	1
36	4	PADZZ	5305-00-054-5644	MSS55195T-11	96906	SCREW,MACHINE.....	EA	1
36	5	PADZZ	5310-00-616-3555	MS35333-71	96906	WASHER,LOCK.....	EA	1
36	6	PADZZ	5305-00-051-6751	MS16995-16	96906	SCREW,CAP,SOCKET HE.....	EA	1
36	7	PADZZ	5305-00-057-0508	MS51958-11	96906	SCREW,MACHINE.....	EA	1
36	8	PADZZ	5305-00-601-9080	304370	12344	SCREW,TENSION ADJ.....	EA	1
36	9	PADZZ	7040-00-054-3417	300480	12344	LATCH,ARMATURE.....	EA	1
36	10	PADZZ	5360-00-926-5421	300371	12344	SPRING.....	EA	2
36	11	PADZZ	5340-00-971-7610	300940	12344	SHIM,ANTI RESI.....	EA	1
36	12	XDDZZ		325370	12344	BRACKET,ESCAPEMENT.....	EA	1
36	13	XDDZZ		AN365C632	88044	NUT,SELF-LOCKING.....	EA	1
36	14	XDDZZ		305300	12344	SCREW,SPECIAL.....	EA	1
36	15	XDDZZ		332843	12344	COIL AND FRAME.....	EA	1
36	16	PAHDL	7040-00-019-3054	3298170	12344	COIL ASSEMBLY,ELECT.....	EA	1
36	17	XDDZZ	5935-00-905-5738	M7PLSH9	81312	CONNECTOR,PLUG,ELEC.....	EA	1
36	18	PADDL	7040-00-121-9078	306150	123444	CLUTCH AND SLEEVE ASSY FOR..... BREAKDOWN SEE FIG. 35	EA	1
					97			

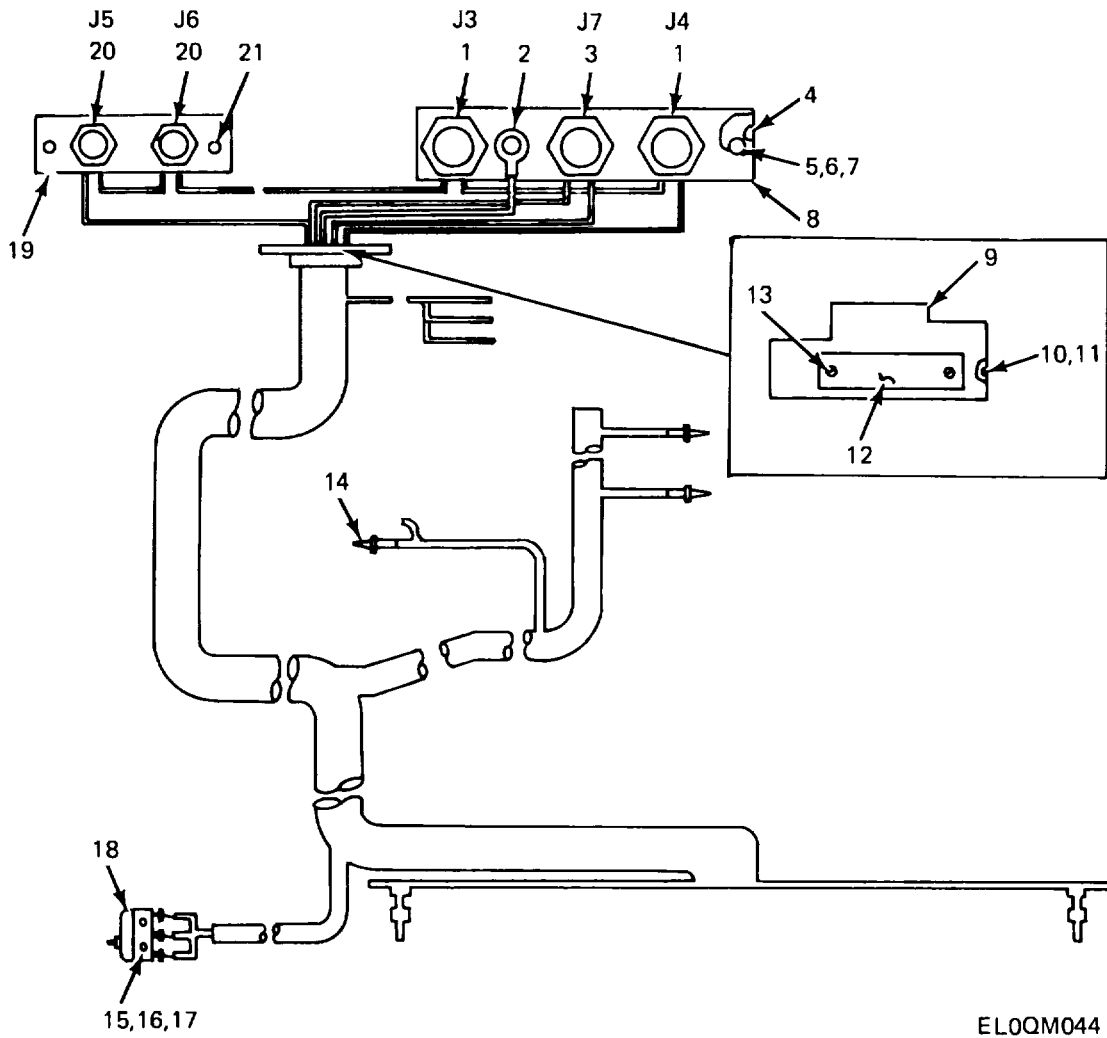

Figure 37. Cable Assembly, Mechanism.

SECTION II

(1) ILLUSTRATION		(2)	(3)	(4)	(5)	(6)	(7)	(8)
(a) FIG NO.	(b) ITEM NO.	SMR CODE	NATIONAL STOCK NUMBER	PART NUMBER	FSCM	DESCRIPTION USABLE ON CODE	U/M	QTY INC IN UNIT
						GROUP 04020305 CABLE ASSEMBLY,MECHANISM		
37	1	PADZZ	5935-00-642-3813	M7SLRN	81321	CONNECTOR,RECEPTACL.....	EA	2
37	2	XDDZZ		4110300	12344	TERMINAL,LUG.....	EA	1
37	3	PADZZ	5935-00-973-7852	M1OSLRN	81312	CONNECTOR,RECEPTACL.....	EA	1
37	4	XDDZZ		146043	12344	SPACER.....	EA	2
37	5	PADZZ	5305-00-054-6655	MS51957-31	96906	SCREW,MACHINE.....	EA	1
37	6	PADZZ	5310-00-883-9385	MS35338-155	96906	WASHER,LOCK.....	EA	1
37	7	PADZZ	5310-00-531-9514	N960C6	880441	WASHER,FLAT.....	EA	1
37	8	XDDZZ		327300	12344	PLATE,MTG,RIGHT.....	EA	1
37	9	XDDZZ		393910	12344	PLATE,MOUNTING.....	EA	1
37	10	PADZZ	5305-00-054-5648	MS51957-4	96906	SCREW,MACHINE.....	EA	1
37	11	PADZZ	5310-00-933-8118	MS35338-135	96906	WASHER,LOCK.....	EA	1
37	12	XDDZZ		394040	12344	CONNECTOR ASSEMBLY.....	EA	1
37	13	PADZZ	5305-00-054-5646	MS51957-12	96906	SCREW,MACHINE.....	EA	2
37	14	PADZZ	5940-00-793-7286	41663	00779	TERMINAL,TAPER PIN.....	EA	1
37	15	PADZZ	5305-00-054-5639	MS51957-5	96906	SCREW,MACHINE.....	EA	1
37	16	PADZZ	5310-00-183-4354	AN96OC2L	88044	WASHER,FLAT.....	EA	1
37	17	PADZZ	5310-00-543-4652	MS353533-69	96906	WASHER,LOCK.....	EA	1
37	18	PADZZ	5930-00-818-7799	11SM23T	91929	SWITCH,SENSITIVE.....	EA	1
37	19	XDDZZ		300860	12344	PLATE,MTG,LEFT.....	EA	1
37	20	XDDZZ		M4SLRN	81312	CONNECTOR,RECEPTACL.....	EA	2
37	21	PADZZ	5305-00-054-6651	MS51957-27	96906	SCREW MACHINE.....	EA	1
					99			

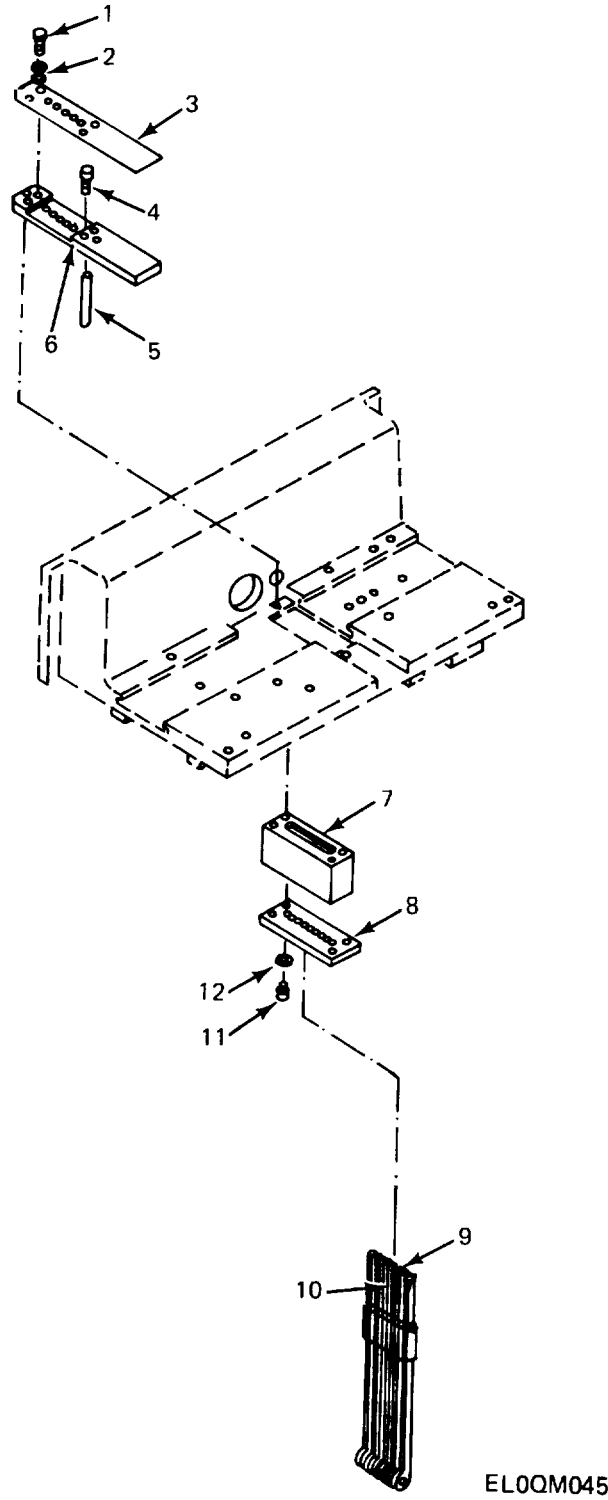
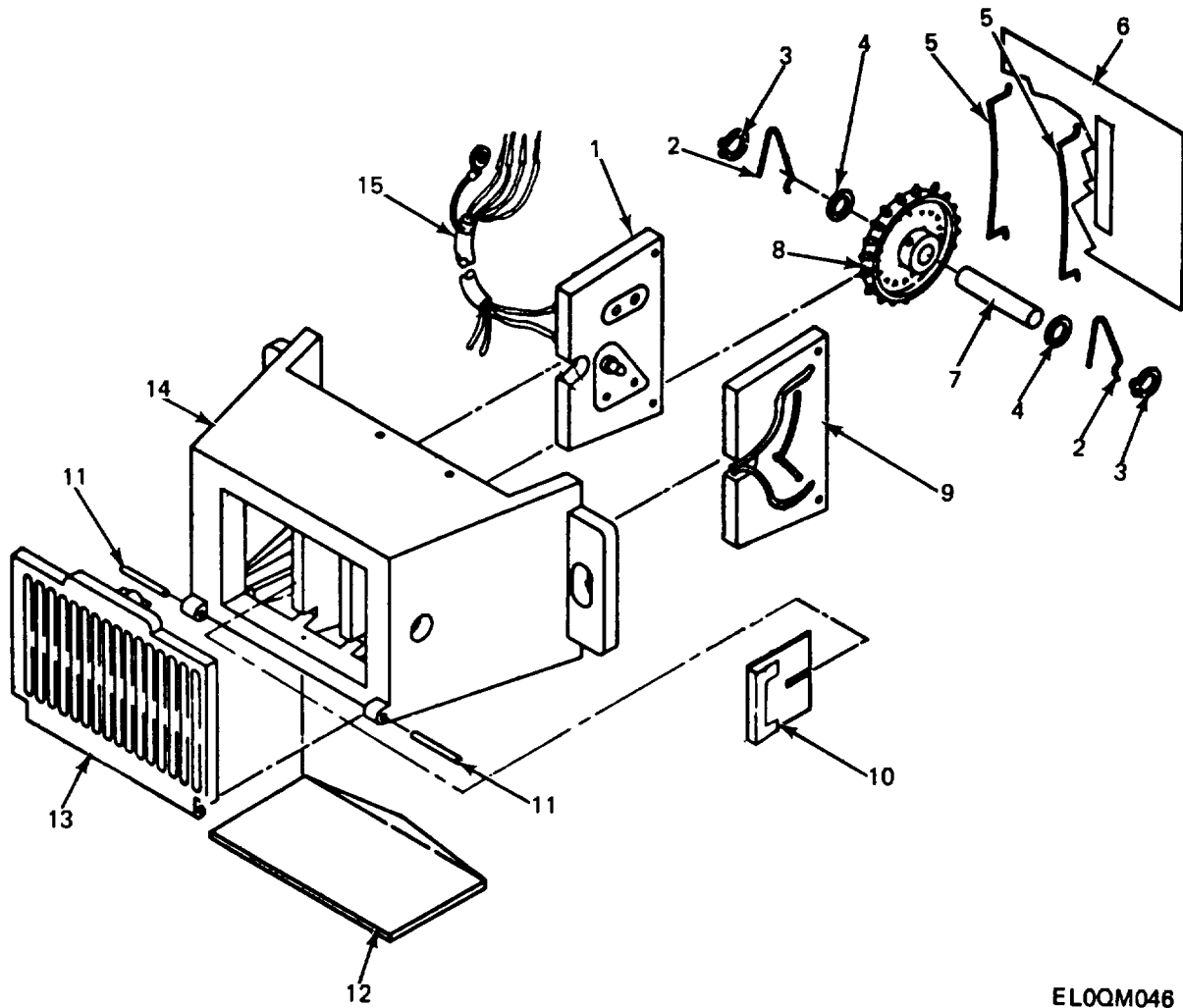

Figure 38. Head, Punch Assembly.

SECTION II

TM 11-7440-222-40P/NAVELEX 0967-LP-324-0480/TO 31W4-2G-84

(1) ILLUSTRATION		(2)	(3)	(4)	(5)	(6) DESCRIPTION	(7)	(8)
(a) FIG NO.	(b) ITEM NO.	SMR CODE	NATIONAL STOCK NUMBER	PART NUMBER	FSCM	USABLE ON CODE	U/M	QTY INC IN UNIT
						GROUP 04020306 HEAD,PUNCH ASSEMBLY		
38	1	PADZZ	5305-00-111-5185	400617-27	12344	SCREW	EA	1
38	2	PADZZ	5310-00-543-2410	MS35338-40	96906	WASHER,LOCK	EA	1
38	3	XDDZZ		325470	12344	PLATE,DIE	EA	1
38	4	PADZZ	5305-00-311-5341	4155600	12344	SCREW,MACHINE.....	EA	1
38	5	XDDZZ		300390	12344	DOWEL PIN	EA	1
38	6	XDDZZ		325460	12344	PLATE,STRIPPER	EA	1
38	7	XDDZZ		317430	12344	BLOCK SPACER.....	EA	1
38	8	XDDZZ		325450	12344	PLATE GUIDE.....	EA	1
38	9	XDDZZ		300522	12344	PUNCH DRIVE ASSY	EA	1
38	10	XDDZZ		300521	12344	PUNCH DRIVE ASSY	EA	1
38	11	PADZZ	5305-00-316-0357	4155300	12344	SCREW,CAP,SOCKET HE	EA	1
38	12	XDDZZ		4178700	12344	WASHER,LOCK	EA	1
					101			



EL0QM046

Figure 39. Sensor Assembly, Tape Motion.

SECTION II

TM 11-7440-222-40P/NAVELEX 0967-LP-324-0480/TO 31W4-2G-84

(1) ILLUSTRATION		(2)	(3)	(4)	(5)	(6)	(7)	(8)
(a) FIG NO.	(b) ITEM NO.	SMR CODE	NATIONAL STOCK NUMBER	PART NUMBER	FSCM	DESCRIPTION USABLE ON CODE	U/M	QTY INC IN UNIT
						GROUP 040204 SENSOR ASSEMBLY,TAPE MOTION		
39	1	PADZZ	7040-00-989-3623	833594	12344	LIGHT SENSOR CARD A	EA	1
39	2	PADZZ	7040-00-898-7026	329100	12344	SPRING,PIVOT SHAFT	EA	2
39	3	PADZZ	5365-00-957-7776	5555G9MD	791361	RING,RETAINING	EA	2
39	4	PADZZ	5365-00-686-5929	309793	12344	SHIM.....	EA	2
39	5	PADZZ	5340-00-057-7803	329090	12344	SPRING,RETAINER.....	EA	2
39	6	PADZZ	7040-00-152-0054	394220	12344	COVER,DUST	EA	1
39	7	PADZZ	7040-00-054-3435	329000	12344	SHAFT,CAPSTAN.....	EA	1
39	8	PADZZ	7040-00-895-3973	325110	12344	CAPSTAN,SENSING.....	EA	1
39	9	PADZZ	7040-00-989-3627	832637	12344	LIGHT SENSOR CARD A	EA	1
39	10	XDDZZ		347760	12344	CLIP,SPLIT.....	EA	1
39	11	PADZZ	5315-00-057-7797	329260	12344	PIN	EA	2
39	12	XDDZZ		374970	12344	TAPE,BLADE	EA	1
39	13	XDDZZ		329080	12344	LID,HOUSING	EA	1
39	14	XDDZZ		325171	12344	HOUSING.....	EA	1
39	15	XDDZZ		396130	12344	SHEATHING.....	EA	1
					103			

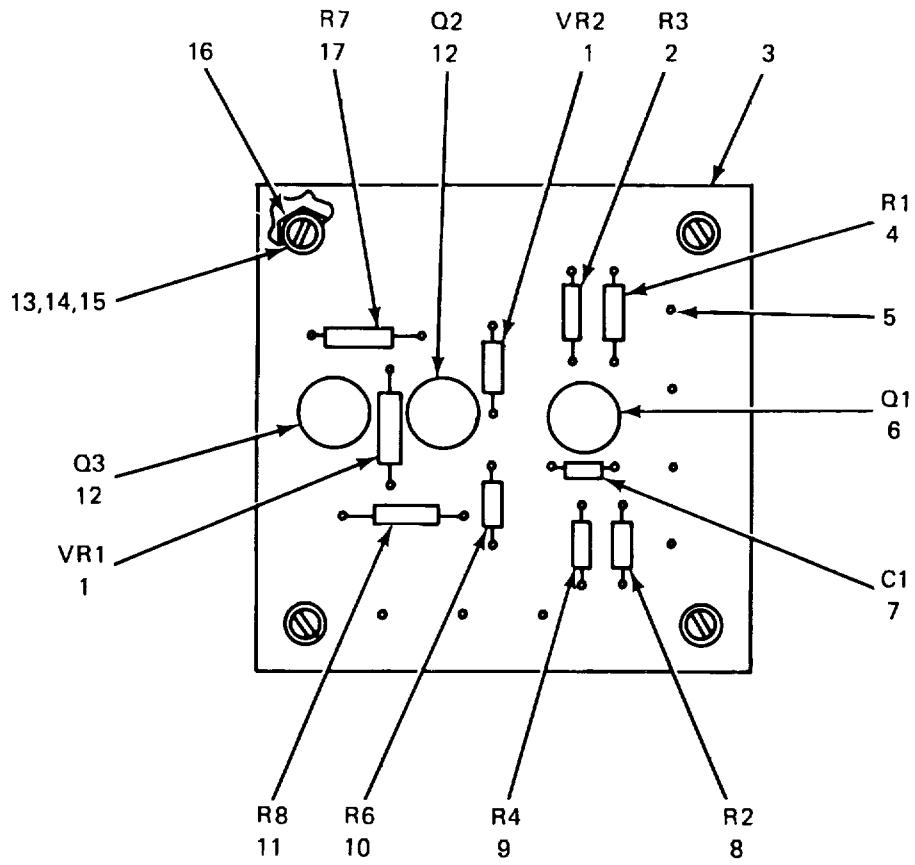

ELOQM047

Figure 40. Circuit Card Assembly (890050).

SECTION II

TM 11-7440-222-40P/NAVELEX 0967-LP-324-0480/TO 31W4-2G-84

(1) ILLUSTRATION		(2)	(3)	(4)	(5)	(6) DESCRIPTION	(7)	(8)
(a) FIG NO.	(b) ITEM NO.	SMR CODE	NATIONAL STOCK NUMBER	PART NUMBER	FSCM	USABLE ON CODE	U/M	QTY INC IN UNIT
						GROUP 040205 CIRCUIT CARD ASSEMBLY (890050)		
40	1	PADZZ	5961-00-805-7874	IN750A	80131	SEMICONDUCTOR CODE	EA	2
40	2	PADZZ	5905-00-811-0673	RCOGF682K	81349	RESISTOR, FIXED, COMP	EA	1
40	3	XDDZZ		903450	12344	PRINTED CIRCUIT SD	EA	1
40	4	PADZZ	5905-00-686-3368	C076F23J	81349	RESISTOR, FIXED, COMP	EA	1
40	5	XDDZZ	5940-00-144-1986	2186-2	71279	TERMINAL, STUD	EA	7
40	6	PADZZ	5961-00-930-5325	2N3565	80131	TRANSISTOR	EA	1
40	7	XDDZZ		2DDH6OL417K	71590	CAPACITOR	EA	1
40	8	PADZZ	5905-00-686-4530	RCO7GF1004K	81349	RESISTOR, FIXED, C	EA	1
40	9	PADZZ	5905-00-726-5340	RCO7IGOIK	81349	RESISTOR, FIXED, COMP	EA	1
40	10	PADZZ	5905-00-752-3340	RCOTGF4T2K	81349	RESISTOR, FIXED, COMP	EA	1
40	11	PADZZ	5905-00-195-6817	RC20GF102K	81349	RESISTOR, FIXED, COMP	EA	1
40	12	PADZZ	5961-00-752-0150	2NI69	80131	TRANSISTOR	EA	2
40	13	PADZZ	5310-00-616-3555	MS35333-71	96906	WASHER, LOCK	EA	4
40	14	PADZZ	5310-00-638-9857	AN960C6L	88044	WASHER, FLAT	EA	4
40	15	PADZZ	5305-00-054-6650	MS51957-26	96906	SCREW, MACHINE	EA	4
40	16	X0DZZ		321011	12344	STANDOFF	EA	4
40	17	PADZZ	5905-00-104-8334	RC20GF331K	81349	RESISTOR, FIXED, COMP	EA	1
					105			

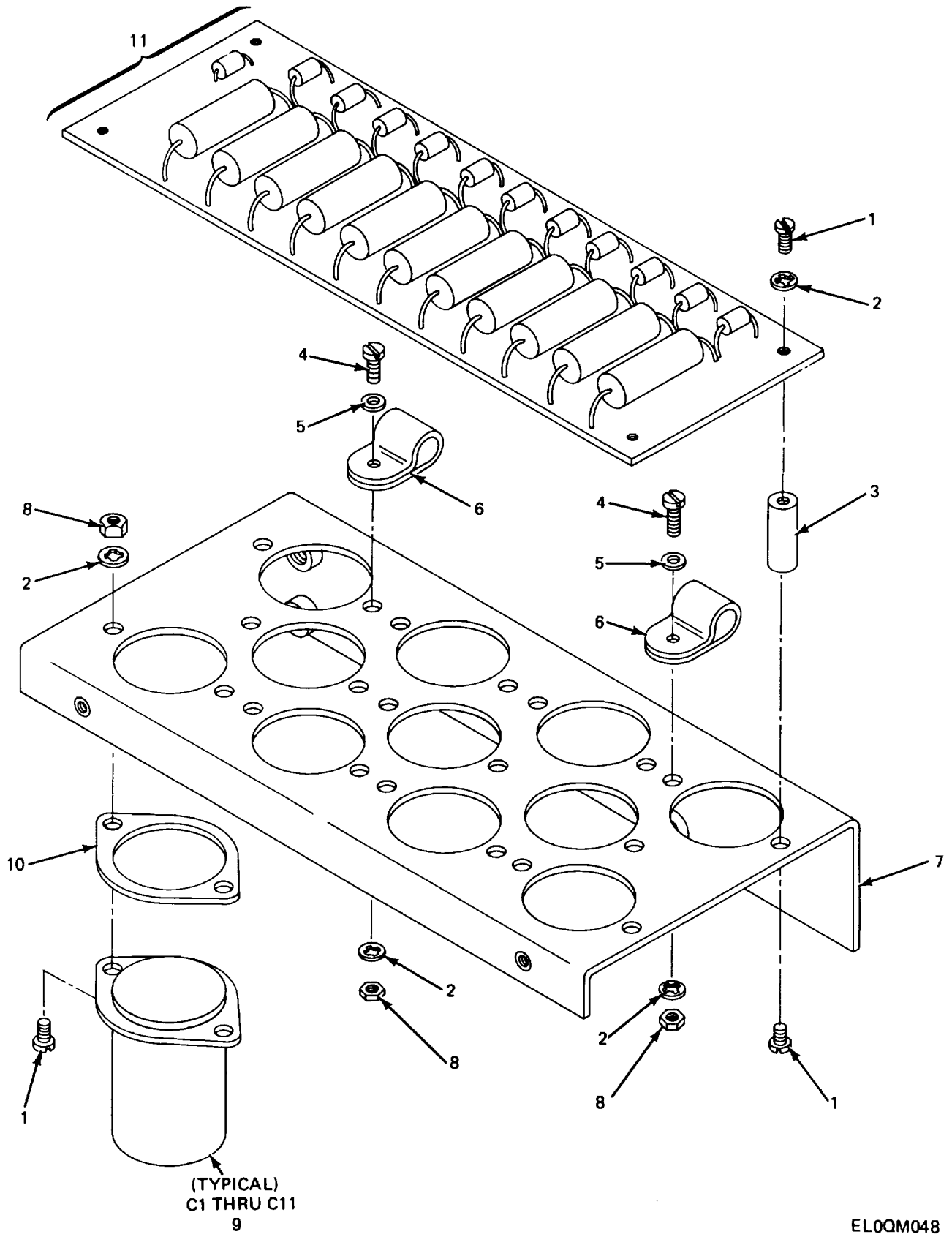

ELOQM048

Figure 41. Network Resistance-Capacitance Assembly.

SECTION II

TM 11-7440-222-40P/NAVELEX 0967-LP-324-0480/TO 31W4-2G-84

(1) ILLUSTRATION		(2)	(3)	(4)	(5)	(6)	(7)	(8)
(a) FIG NO.	(b) ITEM NO.	SMR CODE	NATIONAL STOCK NUMBER	PART NUMBER	FSCM	DESCRIPTION USABLE ON CODE	U/M	QTY INC IN UNIT
						GROUP 040206 NETWORK RESISTANCE- CAPACITANCE ASSEMBLY		
41	1	PAHZZ	5305-00-054-6654	MS51957-30	96906	SCREW,MACHINE.....	EA	4
41	2	PAHZZ	5310-00-616-3555	MS35333-71	96906	WASHER,LOCK.....	EA	4
41	3	XDHZZ		321010	12344	POST,EQUIPMENT.....	EA	4
41	4	PAHZZ	5305-00-054-6652	MS51957-28	96906	SCREW,MACHINE.....	EA	2
41	5	PAHZZ	5310-00-638-9857	AN960C6L	88044	WASHER,FLAT.....	EA	2
41	6	XDHZZ		4097905	12344	CLAMP,LOOP.....	EA	3
41	7	XDHZZ		376670	12344	BRACKET,MOUNTING.....	EA	1
41	8	XDHZZ		4172900	12344	NUT,HEXAGON.....	EA	4
41	9	PAHZZ	5910-00-809-8088	AFH2-06-20	00656	CAPACITOR,FIXED,ELE.....	EA	11
41	10	PAHZZ	5910-00-194-7807	8P4	37942	RETAINER,CAPACITOR.....	EA	11
41	11	PAHDL	7035-00-989-3628	833070	12344	PRINTED WIRING BOAR.....	EA	1
					107			

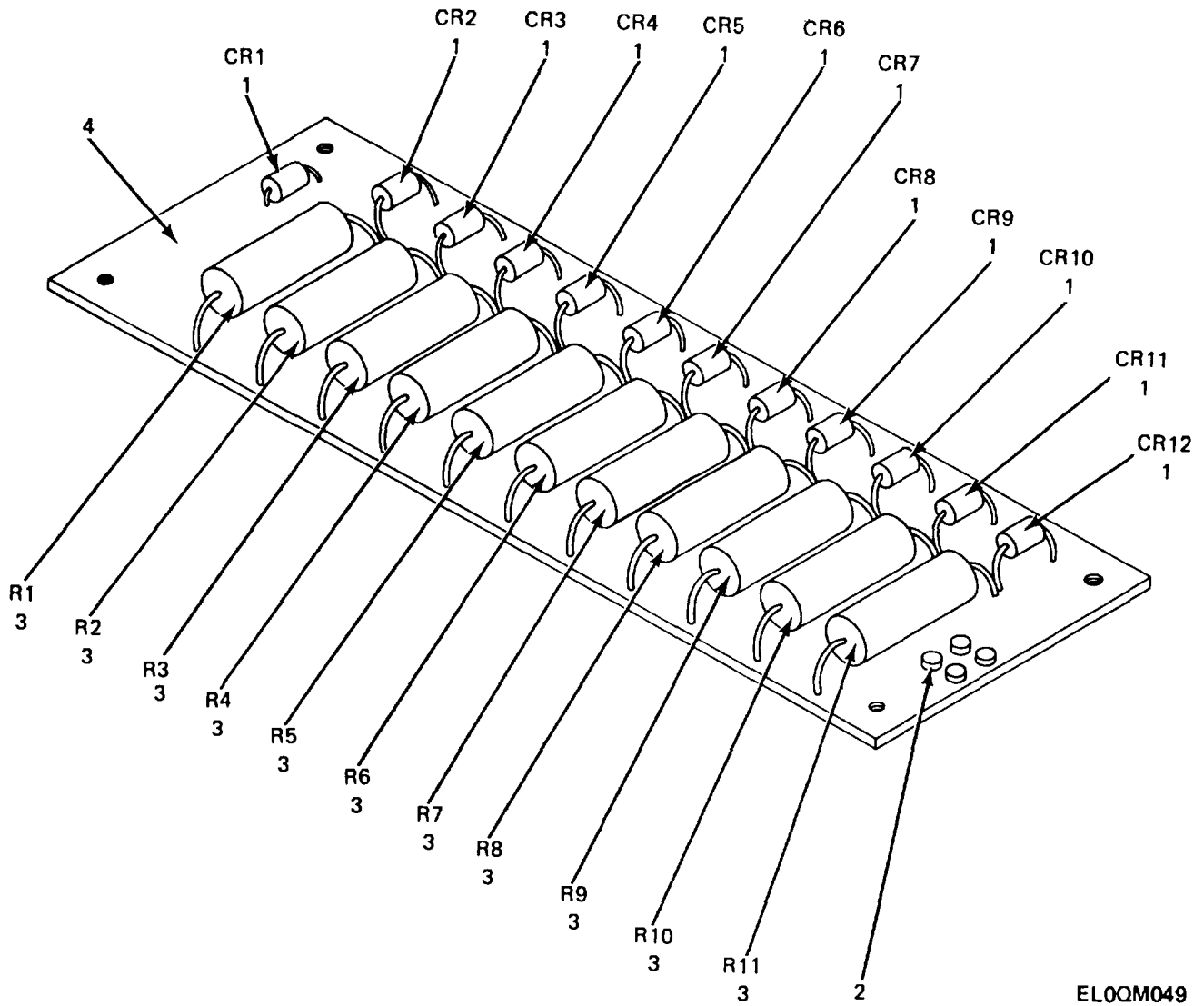

ELOQM049

Figure 42. Circuit Card Assembly (833070).

SECTION II

TM 11-7440-222-40P/NAVELEX 0967-LP-324-0480/TO 31W4-2G-84

(1) ILLUSTRATION		(2)	(3)	(4)	(5)	(6)	(7)	(8)
(a) FIG NO.	(b) ITEM NO.	SMR CODE	NATIONAL STOCK NUMBER	PART NUMBER	FSCM	DESCRIPTION USABLE ON CODE	U/M	QTY INC IN UNIT
						GROUP 04020601 CIRCUIT CARD ASSEMBLY (833070)		
42	1	PADZZ	5961-00-924-6981	JAN1N4245	81349	SEMICONDUCTOR,DIODE	EA	12
42	2	XDDZZ	5940-00-144-1986	216-2	71279	TERMINAL,STUD.....	EA	4
42	3	XDDZZ		RW57G510	81349	RESISTOR,FXD,WW	EA	11
42	4	XDDZZ		903090	12344	PRINTED CIRCUIT BD	EA	1
					109			

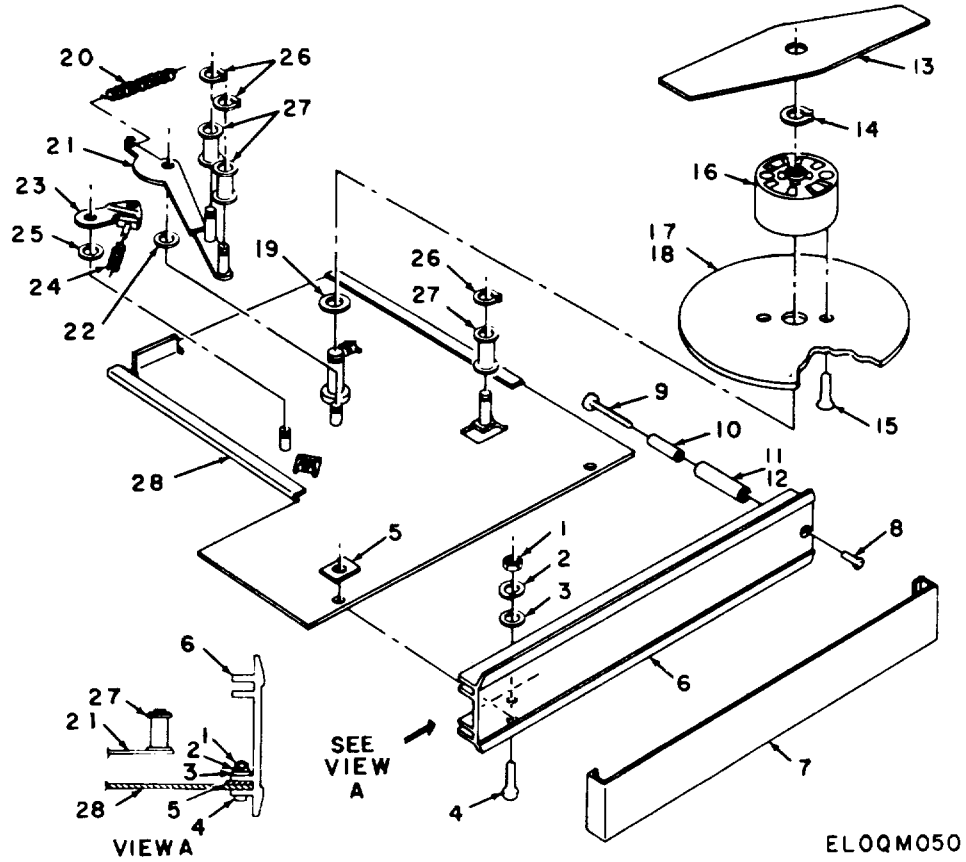

Figure 43. Tape Supply Slide Assembly.

110 Change 1

SECTION II

TM 11-7440-222-40P/NAVELEX 0967-LP-324-0480/TO 31W4-2G-84

(1) ILLUSTRATION		(2)	(3)	(4)	(5)	(6) DESCRIPTION	(7)	(8)
(a) FIG NO.	(b) ITEM NO.	SMR CODE	NATIONAL STOCK NUMBER	PART NUMBER	FSCM	USABLE ON CODE	U/M	QTY INC IN UNIT
						GROUP 040207 TAPE SUPPLY SLIDE ASSEMBLY		
N 43	1	PAHZZ	5310-00-934-9761	MS35649-264	96906	NUT HEXAGON NO 6-32.....	EA	2
N 43	2	PAHZZ	5310-00-929-6395	MS35338-136	96906	WASHER, LOCK	EA	2
N 43	3	PAHZZ	5310-00-722-5948	MS15795-805	96906	WASHER, FLAT	EA	2
N 43	4	PAHZZ	5305-00-064-6655	MS51957-31	96906	SCREW, PAN HEAD NO.6-32 5/8 IN LONG....	EA	2
N 43	5	XBHZZ		01-004474-001	06809	SPACER.....	EA	2
N 43	6	PAHZZ	4935-01-003-8410	398270	12344	SUPPLY SLIDE HANDLER.....	EA	2
N 43	7	PAHZZ	4935-01-003-8409	324130	12344	HANDLE COVER	EA	1
N 43	8	PADZZ	5305-00-719-5064	MS51959-30	96906	SCREW, FLAT HEAD NO 6-32.....	EA	1
N 43	9	PAHZZ	7040-00-895-3982	304670	12344	ROLLER SHAFT	EA	1
N 43	10	PAHZZ	7440-00-152-0041	345521	12344	TAPE ROLLER.....	EA	1
N 43	11	PAHZZ	7445-00-411-8654	318870	12344	POST, TAPE GUIDE	EA	1
N 43	12	PAHHD	7440-00-318-7623	333052	12344	ROLLER ASSY.....	EA	1
N 43	13	PAHZZ	7040-00-009-3471	333751	12344	FRONT FLANGER	EA	1
N 43	14	XBHZZ		5100-25MD	79136	RING, RETAINING	EA	1
N 43	15	PAHZZ	5305-00-969-6495	MS524693-C25	96906	SCREW, FLATHEAD NO. 6-32.....	EA	2
N 43	16	XBHZZ		00-002534-001	06809	HUB ASSY	EA	1
N 43	17	XBHZZ		01-004480-001	06809	FLANGE, REAR	EA	1
N 43	18	XBHZZ		00-002535-001	06809	FLANGE ASSY.....	EA	1
N 43	19	PAHZZ	5365-01-048-6054	01-004472-001	06809	SHIM, 0.010 THK	EA	1
N 43	20	PAHZZ	5360-01-048-5990	AE-188-022-1750	91440	SPRING EXTENSION	EA	1
N 43	21	XBHZZ		00-002539-001	06809	ARM TENSION ASSY	EA	1
N 43	22	XBHZZ		01-004472-002	06809	SHIM, .005 IN THK.....	EA	2
N 43	23	XBHZZ		00-002538-001	06809	BRAKE ASSY.....	EA	1
N 43	24	XBHZZ		AC-180-026-688	91440	SPRING.....	EA	1
N 43	25	XBHZZ		01-004472-002	06809	SHIM, .005 IN THK.....	EA	V
N 43	26	PAHZZ	5365-00-598-8635	5555-12	79136	RING, RETAINING	EA	1
N 43	27	XBHZZ		00-002540-001	06809	TAPE ROLLER ASSY	EA	3
N 43	28	XAHHH		00-002537-001	06809	SLIDE ASSY.....	EA	1
111 CHANGE 1								

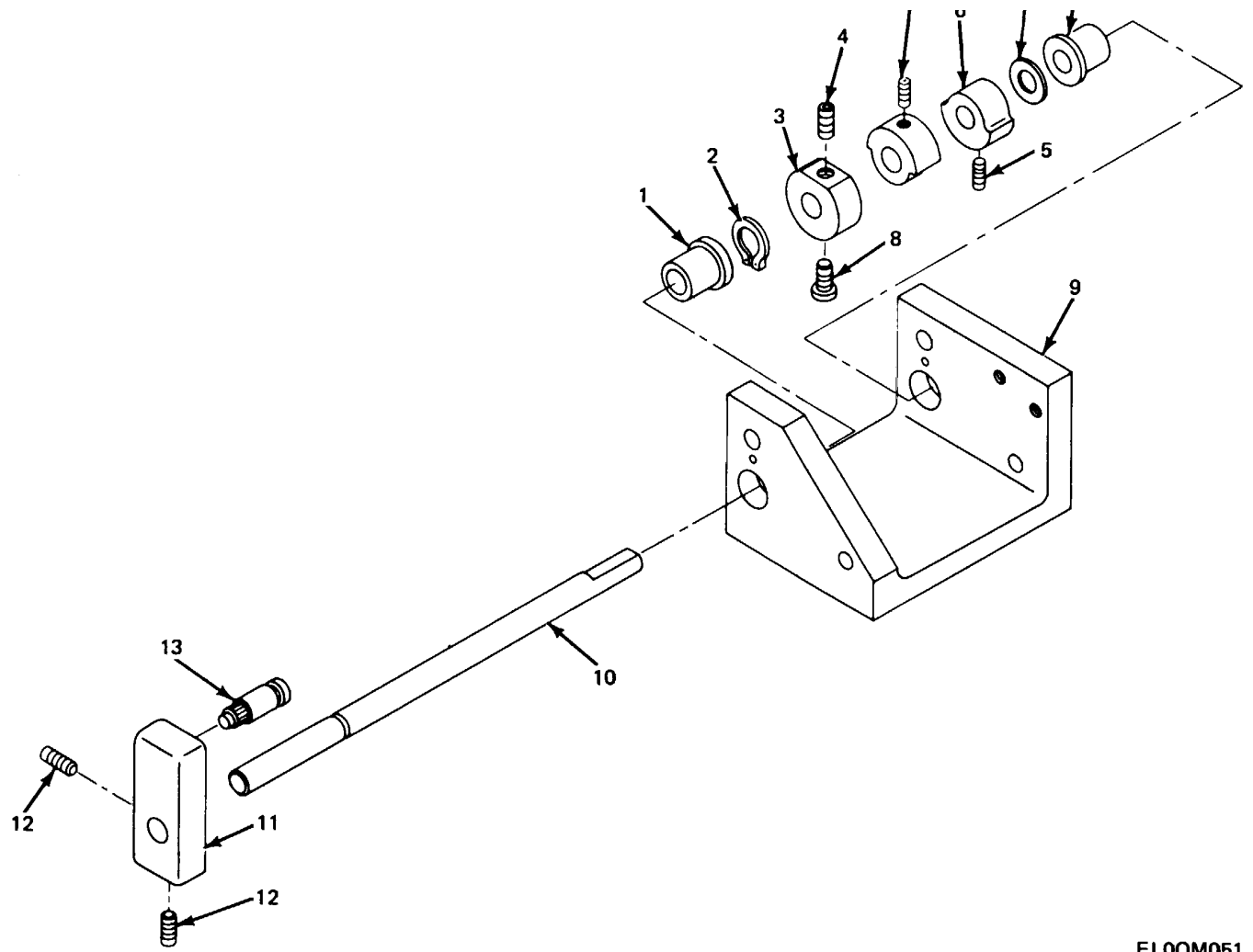

ELOQM051

Figure 44. Sensing Assembly.

SECTION II

TM 11-7440-222-40P/NAVELEX 0967-LP-324-0480/TO 31W4-2G-84

(1) ILLUSTRATION		(2)	(3)	(4)	(5)	(6) DESCRIPTION	(7)	(8)
(a) FIG NO.	(b) ITEM NO.	SMR CODE	NATIONAL STOCK NUMBER	PART NUMBER	FSCM	USABLE ON CODE	U/M	QTY INC IN UNIT
						GROUP 040208 SENSING ASSEMBLY		
44	1	PAHZZ	7040-00-087-8495	304216	12344	BUSHING	EA	2
44	2	PAHZZ	5365-00-63-7444	5103-18MD	79136	RING,RETAINING	EA	2
44	3	XDHZZ		374990	12344	STOP.....	EA	1
44	4	XDHZZ		4158110	12344	SETSCREW	EA	1
44	5	XDHZZ		4153910	12344	SETSCREW	EA	2
44	6	PAHZZ	7025-00-895-3964	333810	12344	CAM,LOOP CONTROL	EA	2
44	7	PAHZZ	5365-00-052-1080	225373	12344	SHIM.....	EA	1
44	8	XDHZZ		4158520	12344	SCREW	EA	1
44	9	XDHZZ		30430	12344	MOUNTING FRAME.....	EA	1
44	10	XDHZZ		376710	12344	SHAFT.....	EA	1
44	11	XDHZZ		312040	12344	ANCHOR,SPRING	EA	1
44	12	XDHZZ		4163500	12344	SCREW,MACHINE.....	EA	2
44	13	PAHZZ	6605-00-908-1052	146701	12344	POST,SPRING	EA	1
					113			

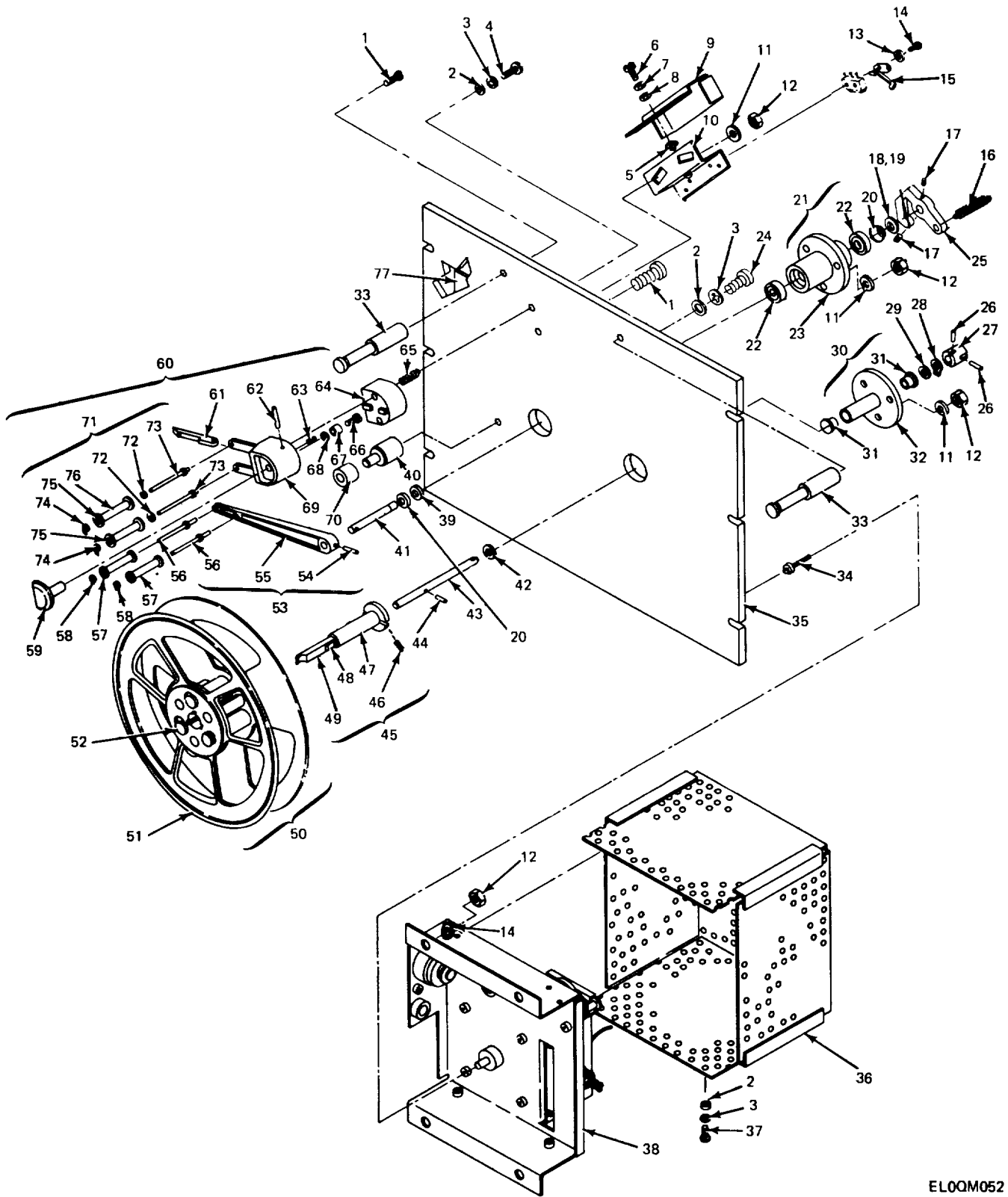

ELOOM052

Figure 45. Tape Reeler B2.

SECTION II

TM 11-7440-222-40P/NAVELEX 0967-LP-324-0480/TO 31W4-2G-84

(1) ILLUSTRATION		(2)	(3)	(4)	(5)	(6)	(7)	(8)
(a) FIG NO.	(b) ITEM NO.	SMR CODE	NATIONAL STOCK NUMBER	PART NUMBER	FSCM	DESCRIPTION USABLE ON CODE	U/M	QTY INC IN UNIT
						GROUP 05 TAPE REELER 82		
45	1	XDHZZ		MS5195-30	96906	SCREW,MACHINE.....	EA	2
45	2	PAHZZ	5310-00-685-3744	AN960C8	88044	WASHER,FLAT.....	EA	3
45	3	PAHZZ	5310-00-543-2739	MS35333-72	96906	WASHER,LOCK.....	EA	3
45	4	XDHZZ		4166850	12344	SCREW,MACHINE.....	EA	2
45	5	XDHZZ	5325-00-263-6641	2185	83330	GROMMET,RUBBER.....	EA	1
45	6	PAHZZ	5305-00-054-6650	MS51957-26	96906	SCREW,MACHINE.....	EA	1
45	7	PAHZZ	5310-00-531-9514	AN960C6	88044	WASHER,FLAT.....	EA	1
45	8	PAHZZ	5310-00-616-3555	MS535333-71	96906	WASHER,LOCK.....	EA	1
45	9	XDHZZ		396430	12344	COVER,HIGH,VOLTAGE.....	EA	1
45	10	XDHZZ		374850	12344	BRACKET ASSEMBLY.....	EA	1
45	11	PAHZZ	5310-00-550-5054	MS15795-809	96906	WASHER,FLAT.....	EA	4
45	12	XDHZZ		4173600	12344	NUT,PLAIN,HEXAGON.....	EA	4
45	13	PAHZZ	5310-00-543-4652	MS35333-69	96906	WASHER,LOCK.....	EA	1
45	14	PAHZZ	5305-00-054-5639	MS51957-5	96906	SCREW,MACHINE.....	EA	1
45	15	PAHZZ	5930-00-929-7869	JS261	91929	ADAPTER,SWITCH ACTU.....	EA	1
45	16	XDHZZ		396620	12344	SPRING,TAPE HANDLER.....	EA	1
45	17	XDHZZ		41639500	112344	SETSCREW.....	EA	1
45	18	PAHZZ	5365-00-178-6045	225375	12344	SHIM.....	EA	1
45	19	PAHZZ	5365-00-182-6731	225376	12344	SHIM.....	EA	1
45	20	XDHZZ		1397960	12344	WASHER.....	EA	1
45	21	XDHHH		374070	12344	BEARING TUBE ASSY.....	EA	1
45	22	PAHZZ	3110-00-805-5590	77R4XRIC	43334	BEARING,BALL,ANNULA.....	EA	2
45	23	XDHZZ		374030	12344	BEARING TUBE.....	EA	1
45	24	XDHZZ		165800	12344	SCREW,MACHINE.....	EA	1
45	25	XDHZZ		359811	12344	CAM ASSEMBLY.....	EA	1
45	26	XDHZZ		4106375	12344	PIN,DOWEL.....	EA	2
45	27	PAHZZ	7040-00-019-3018	370580	12344	COUPLING,REEL DRIVE.....	EA	1
45	28	PAHZZ	5365-00-804-5043	5555-250	19136	RING,RETAINING.....	EA	1
45	29	PAHZZ	5365-00-178-6044	225374	12344	SHIM.....	EA	1
45	30	XDHHH		374060	12344	BEARING TUBE ASSY.....	EA	1
45	31	PAHZZ	6605-00-835-5133	304213	12344	BUSHING,FLANGED.....	EA	1
45	32	XDHZZ		374040	12344	BEARING TUBE.....	EA	1
45	33	XDHZZ		333052	12344	ROLLER ASSEMBLY.....	EA	2
45	34	XDHZZ		364070	12344	STUD,PANEL.....	EA	1
45	35	XDHZZ		373600	12344	PANEL BLANK.....	EA	1
45	36	XDHZZ		373990	12344	COVER,HIGH,VOLTAGE.....	EA	1
45	37	PAHZZ	5305-00-054-6666	MS51957-41	96906	SCREW,MACHINE.....	EA	4
45	38	XDHHH		373610	12344	COMPONENT ASSEMBLY.....	EA	1
45	39	XDHZZ		146043	12344	SPACER.....	EA	1
					115			

SECTION II

TM 11-7440-222-40P/NAVELEX 0967-LP-324-0480/TO 31W4-2G-84

(1) ILLUSTRATION		(2)	(3)	(4)	(5)	(6) DESCRIPTION	(7)	(8)
(a) FIG NO.	(b) ITEM NO.	SMR CODE	NATIONAL STOCK NUMBER	PART NUMBER	FSCM	USABLE ON CODE	U/M	QTY INC IN UNIT
45	40	XDHZZ		374020	12344	STOP,TENSION	EA	1
45	41	XDHZZ		374010	12344	SHAFT	EA	1
45	42	XDHZZ		18808	71041	BEARING,WASHER,THRU	EA	1
45	43	XDHZZ		374000	12344	SHAFT REEL DRIVE	EA	1
45	44	XDHZZ		4107310	12344	PIN,DOWEL	EA	1
45	45	PAHHH	7040-00-229-6570	389700	12344	REEL,ADAPTER	EA	1
45	46	XDHZZ		4159000	12344	SETSCREW	EA	1
45	47	XDHZZ		4107200	12344	ROLL PIN	EA	1
45	48	XDHZZ		228763	12344	ADAPTER	EA	1
45	49	XDHZZ		228771	12344	RETAINER,REEL	EA	1
45	50	PAHHH	7035-00-165-6598	519953	12344	REEL ASSEMBLY	EA	1
45	51	XDHZZ		519951	12344	TAPE REEL	EA	1
45	52	XDHZZ		389620	12344	STOP,REEL	EA	1
45	53	XDHHH		359531	12344	TENSION ARM ASSY	EA	1
45	54	XDHZZ		4106350	12344	PIN,GROOVED	EA	1
45	55	XDHZZ		359590	12344	ARM,TENSION	EA	1
45	56	XDHZZ		356550	12344	PIN,TENSION	EA	2
45	57	XDHZZ	7040-00-398-9663	356571	12344	ROLLER ASSEMBLY,TEN	EA	2
45	58	PAHZZ	5365-00-282-6297	5555-12D	79136	RING,RETAINING	EA	2
45	59	XDHZZ		359900	12344	PUSH BUTTON	EA	1
45	60	XDHHH		359541	12344	DETENT HOUSING ASSY	EA	1
45	61	XDHZZ		35340	12344	LATCH,DETENT ARM	EA	1
45	62	XDHZZ		35370	12344	SHAFT,DETENT	EA	1
45	63	XDHZZ		4153900	12344	SETSCREW	EA	1
45	64	XDHZZ		374050	12344	STANDOFF	EA	1
45	65	XDHZZ		LCO02D3	84830	SPRING,HELI-COIL	EA	2
45	66	XDHZZ		4154900	12344	SCREW,MACHINE	EA	1
45	67	XDHZZ		330230	12344	SPACER	EA	1
45	68	PAHZZ	5310-00-782-1349	AN960C4	88044	WASHER,FLAT	EA	1
45	69	XDHZZ		359410	12344	HOUSING DETENT	EA	1
45	70	XDHZZ	7045-00-112-8748	353550	12344	CUSHION	EA	1
45	71	XDHHH	7040-00-398-9663	356571	12344	ROLLER ASSEMBLY,TEN	EA	1
45	72	XDHZZ		305653	12344	SHIM	EA	2
45	73	XDHZZ		356551	12344	PIN,ROLLER	EA	2
45	74	PAHZZ	5365-00-282-6297	5555-12MD	79136	RING,RETAINING	EA	2
45	75	XDHZZ		4083300	12344	BUSHING	EA	2
45	76	XDHZZ		356561	12344	ROLLER,TENSION ARM	EA	1
45	77	XDHZZ		380010	12344	PLATE,IDENT	EA	1
116/(117 blank)								

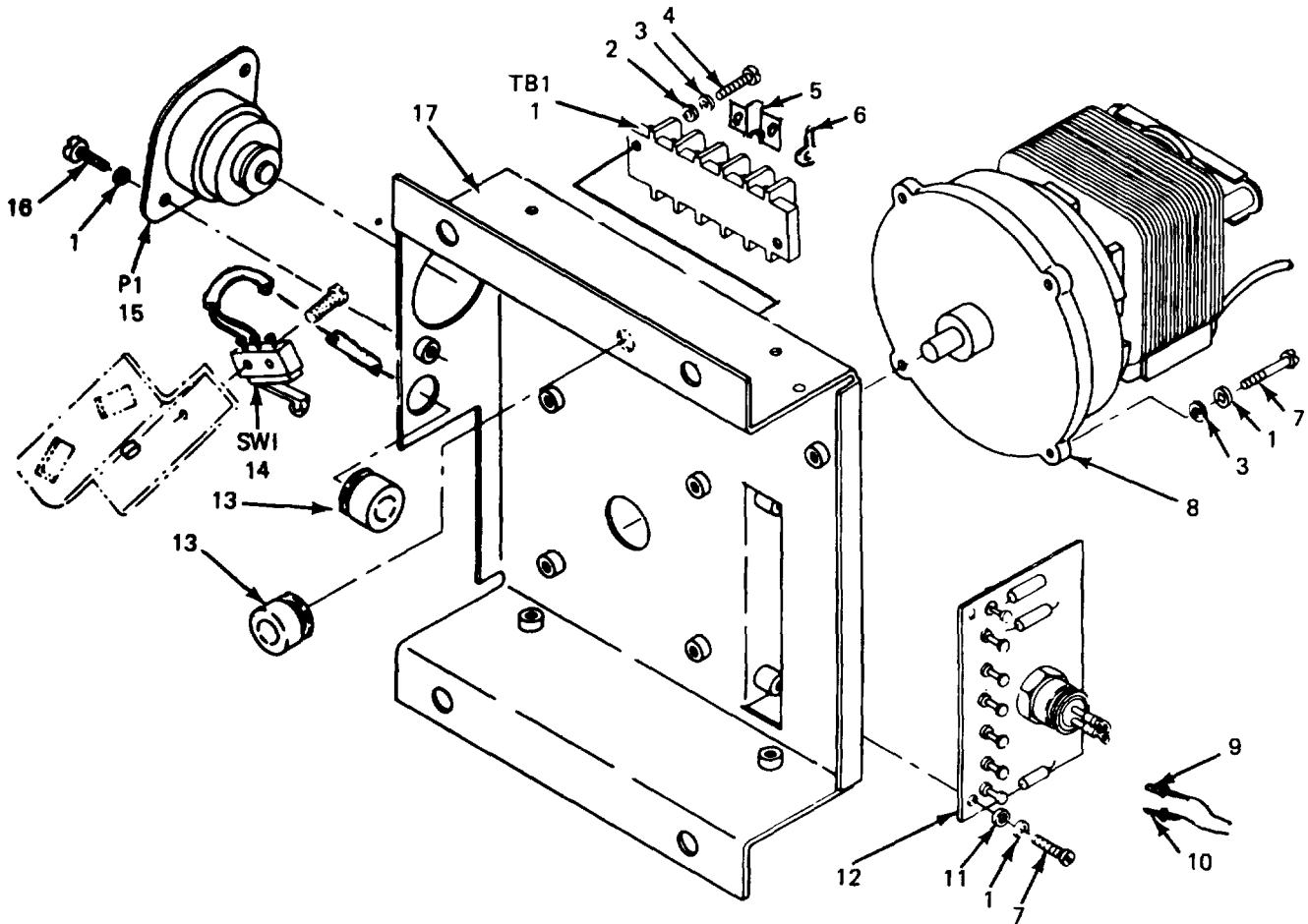

COMPONENT ASSY

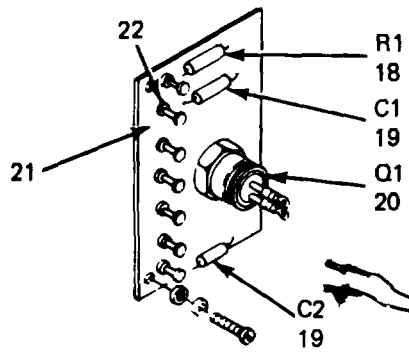

CIRCUIT CARD ASSY

EL0QM053

Figure 46. Component Assembly and Circuit Card Assembly (890202).

SECTION II

TM 11-7440-222-40P/NAVELEX 0967-LP-324-0480/TO 31W4-2G-84

(1) ILLUSTRATION		(2)	(3)	(4)	(5)	(6) DESCRIPTION	(7)	(8)
(a) FIG NO.	(b) ITEM NO.	SMR CODE	NATIONAL STOCK NUMBER	PART NUMBER	FSCM	USABLE ON CODE	U/M	QTY INC IN UNIT
						GROUP 0501 COMPONENT ASSEMBLY		
46	1	PAHZZ	5940-00-983-6046	5-140	71785	TERMINAL BOARD.....	EA	1
46	2	PAHZZ	5310-00-531-9514	AP6OC6	88044	WASHER,FLAT	EA	3
46	3	PAHZZ	5310-00-616-3555	535333-71	96906	WASHER,LOCK	EA	3
46	4	PAHZZ	5305-00-050-6655	MS51957-31	96906	SCREW,MACHINE.....	EA	2
46	5	PAHZZ	5940-00-682-2427	141J	71785	JUMPER.....	EA	1
46	6	PAHZZ	5940-00-283-5280	86523-06	98410	TERMINAL,LUG	EA	1
46	7	PAHZZ	5305-00-054-6654	551957-30	96906	SCREW MACHINE.....	EA	2
46	8	PAHZZ	6105-00-125-3309	376970	12344	GEARCASE-MOTOR	EA	1
46	9	PAHZZ	5940-00-793-7286	41663	007791	TERMINAL,TAPER PIN.....	EA	1
46	10	XDHZZ		4108400	12344	PIN,TAPER.....	EA	1
46	11	XDDZZ		A96OC16L	88041	WASHER,FLAT	EA	1
46	12	PADZZ	7040-00-019-3020	890202	12344	CIRCUIT CARD ASSEMB.....	EA	1
46	13	XDHZZ		4116155	12344	BUSHING,SNAP	EA	2
46	14	PAHZZ	5930-00-583-8861	11SM1T	91929	SWITCH,SENSITIVE.....	EA	1
46	15	PAHZZ	5935-00-107-1283	7484	74545	CONNECTOR,PLUG,ELEC	EA	
46	16	PAHZZ	5305-00-054-6650	MS51957-26	96906	SCREW,MACHINE.....	EA	1
46	17	XDHZZ		373590	12344	BRACKET,MOTOR	EA	1
						GROUP 050101 CIRCUIT CARD ASSEMBLY (890202)		
46	18	PADZZ	5905-00-186-3008	RC20GF101K	81349	RESISTOR,FIXED,COMP	EA	1
46	19	PADZZ	5910-00-341-2437	P12D	02777	CAPACITOR,FIXED,PAP	EA	2
46	20	PADZZ	5961-00-079-6951	SC40B	109214	SEMICONDUCTOR DEVIC.....	EA	1
46	21	XDDZZ		904030	12344	PRINTED CIRCUIT	EA	1
46	22	XDDZZ	5940-00-144-1986	2186-2	71279	TERMINAL,STUD.....	EA	7
					119			

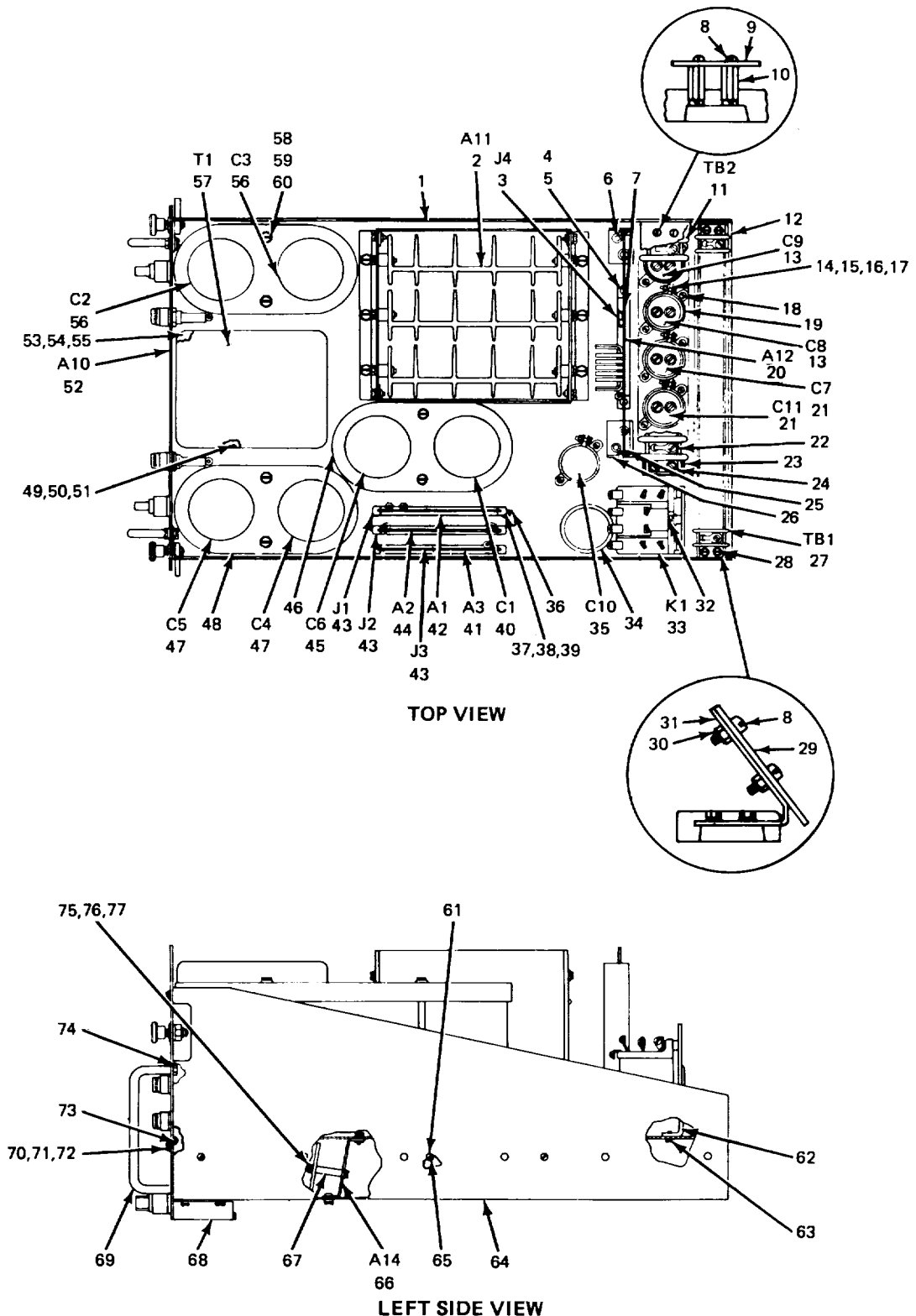

Figure 47. Power Supply PS1.

SECTION II

TM 11-7440-222-40P/NAVELEX 0967-LP-324-0480/TO 31W4-2G-84

(1) ILLUSTRATION		(2)	(3)	(4)	(5)	(6) DESCRIPTION	(7)	(8)
(a) FIG NO.	(b) ITEM NO.	SMR CODE	NATIONAL STOCK NUMBER	PART NUMBER	FSCM	USABLE ON CODE	U/M	QTY INC IN UNIT
						GROUP 06 POWER SUPPLY PSI		
47	1	XDHZZ		40-000066-2	06809	PLATE,LEFT SIDE	EA	1
47	2	XDHHH		40-000083-1	06809	HEATSINK ASSEMBLY	EA	1
47	3	XDHZZ		250-25-36-170	71751	CONNECTOR,RCPT,ELEC.....	EA	1
47	4	PAHZZ	5305-00-054-5651	MS51957-17	96906	SCREW,MACHINE.....	EA	2
47	5	PAHZZ	5310-00-013-4524	MS35649-42	96906	NUT,PLAIN,HEXAGON	EA	2
47	6	XDHZZ		40-000067-2	06809	BRACKET.....	EA	1
47	7	XDHZZ		456-99-99-193	71785	KEY,POLARIZING ELEC	EA	1
47	8	XDHZZ		A1-10977F-5	14850	SCREW,MACHINE.....	EA	8
47	9	XDHZZ		A1-10980C	14850	SHIELD ASSEMBLY	EA	1
47	10	XDHZZ		DI-109848-1	14850	STANDOFF	EA	4
47	11	XDHZZ	5940-00-935-8256	603CY1251	75382	TERMINAL BOARD.....	EA	1
47	12	XDHHH		40-000062-1	06809	CHASSIS.....	EA	1
47	13	PAHZZ	5910-00-050-5331	86F1065MA	03508	CAPACITOR,FIXED,ELEC.....	EA	2
47	14	PAHZZ	5310-00-013-4530	MS35649-62	96906	NUT,PLAIN,HEXAGON	EA	5
47	15	PAHZZ	5305-00-054-6655	MS51957-31	96906	SCREW,MACHINE.....	EA	4
47	16	PAHZZ	5310-00-082-1404	MS27183-6	96906	WASHER,FLAT	EA	4
47	17	PAHZZ	5310-00-045-4007	MS35338-41	96906	WASHER,LOCK	EA	4
47	18	PAHZZ	5305-00-054-6652	MS51957-2B	96906	SCREW,MACHINE.....	EA	8
47	19	XDHZZ		97A	94682	RETAINER,CAPACITOR.....	EA	5
47	20	PAHDL	7040-00-01-9706	40-000052-1	12436	CIRCUIT CARD ASSEMB.....	EA	1
47	21	PAHZZ	5910-00-050-5330	86F1064MA	03508	CAPACITOR,FIXED,ELE	EA	2
47	22	PAHZZ	5325-00-817-1158	A510	57771	EYELET,METALLIC	EA	1
47	23	XDHZZ		40-000120-1	06809	RETAINER	EA	1
47	24	XDHZZ		40-000095-1	06809	BRACKET,ANGLE.....	EA	2
47	25	PAHZZ	5821-00-961-3243	58-30-40	07556	GUIDE,CIRCUIT CARD.....	EA	2
47	26	XDHZZ		40-000067-1	06809	BRACKET.....	EA	1
47	27	XDHZZ		602CY1S1	75382	TERMINAL BOARD.....	EA	1
47	28	PAHZZ	5310-00-596-8131	MS632-2	46384	NUT,PLAIN,CLINCH.....	EA	4
47	29	XDHZZ		D1-10981C	14850	SHIELD.....	EA	1
47	30	XDHZZ	5310-00-934-9747	MS35649-262	96906	NUT,PLAIN,HEXAGON	EA	4
47	31	XDHZZ		01-10987C	14850	BRACKET.....	EA	2
47	32	PAHZZ	5305-00-054-6670	551957-45	96906	SCREW,MACHINE.....	EA	7
47	33	PAHZZ	5945-00-100-4743	PMI5024VDC	12300	RELAY,SOLENOID	EA	1
47	34	XDHZZ		1139	70485	GROMMET,RUBBER	EA	1
47	35	PAHZZ	5910-00-050-5332	86F1067MA	03508	CAPACITOR,FIXED,ELE	EA	1
47	36	XDHZZ	5945-00-465-9919	60-6002-31-24	91662	POLARIZING TAB,RELA.....	EA	3
47	37	PAHZZ	5305-00-054-5648	MS51957-14	96906	SCREW,MACHINE.....	EA	8
47	38	PAHZZ	5310-00-983-8463	MS27183-5	96906	WASHER,FLAT	EA	8
47	39	PAHZZ	5310-00-543-2410	MS3533B-40	96906	WASHER,LOCK	EA	8
					121			

SECTION II

TM 11-7440-222-40P/NAVELEX 0967-LP-324-0480/TO 31W4-2G-84

(1) ILLUSTRATION		(2)	(3)	(4)	(5)	(6)	(7)	(8)
(a) FIG NO.	(b) ITEM NO.	SMR CODE	NATIONAL STOCK NUMBER	PART NUMBER	FSCM	DESCRIPTION USABLE ON CODE	U/M	QTY INC IN UNIT
47	40	PAHZZ	5910-00-054-4243	86F2004NA	03508	CAPACITOR, FIXED, ELE	EA	1
47	41	PAHDL	7040-00-018-9637	40-00014-1	12436	CIRCUIT CARD ASSEM	EA	1
47	42	XDHDL		40-0008-1	06809	CIRCUIT CARD ASSY	EA	1
47	43	PAHZZ	5935-00-050-5387	00-6022-022-940-002	916621	CONNECTOR, RECEPTACL	EA	3
47	44	PAHDL	7040-00-018-9638	40-000011-1	12436	CIRCUIT CARD ASSEM	EA	1
47	45	PAHZZ	5910-00-054-4242	86F1063HA	03508	CAPACITOR, FIXED, ELE	EA	1
47	46	XDHZZ		40-000081-1	06809	CAPACITOR, RING ASSY	EA	3
47	47	PAHZZ	5910-00-054-4241	86F1062MA	03508	CAPACITOR, FIXED, ELE	EA	2
47	48	XDHZZ		40-000124-	06809	INSULATOR, CAP	EA	3
47	49	XDHZZ	5310-00-264-1390	AN961-10	88044	WASHER, FLAT	EA	26
47	50	XDHZZ	5330-00-261-8278	MS35338-100	96906	WASHER, LOCK	EA	13
47	51	XDHZZ		MS20341-108	96906	NUT, PLAIN, HEXAGON	EA	13
47	52	XDHHH		40-000076-1	06809	FRONT PANEL ASSY	EA	1
47	53	PAHZZ	5310-00-682-5930	MS35339-44	96906	WASHER, LOCK	EA	4
47	54	PAHZZ	5310-00-809-4058	MS27183-10	96906	WASHER, FLAT	EA	4
47	55	PAHZZ	5310-00-834-8736	MS35691-2	96906	NUT, PLAIN, HEXAGON	EA	4
47	56	PAHZZ	5910-00-054-4225	86F1061HA	03508	CAPACITOR, FIXED, ELE	EA	2
47	57	PAHZZ	5950-00-097-7508	39359	98675	TRANSFORMER, POWER	EA	1
47	58	XDHZZ		MS20073-60	96906	SCREW, MACHINE	EA	6
47	59	PAHZZ	5310-00-809-8546	527183-8	96906	WASHER, FLAT	EA	10
47	60	XDHZZ	5310-00-045-3296	MS35338-43	96906	WASHER, LOCK	EA	10
47	61	XDHZZ		AN505P6RS	88044	SCREW, MACHINE	EA	10
47	62	XDHZZ		40-000065-1	06809	BRACKET, RELAY	EA	1
47	63	XDHZZ	5310-00-329-1307	SS032-2	46384	NUT, PLAIN, CLINCH	EA	10
47	64	XDHZZ		40-000066-1	06809	PLATE, RIGHT SIDE	EA	1
47	65	XDHZZ		A5632-2	46384	NUT, PLAIN, CLINCH	EA	10
47	66	XDHHH		40-000110-105	06809	CONNECTOR BRKT ASSY	EA	1
47	67	XDHZZ		40-000116-1	06809	POST, ELEC, MECHANISM	EA	2
47	68	XDHZZ		40-000078-1	06809	COVER, FUSE	EA	1
47	69	XDHZZ		MS390783	96906	HANDLE, BOW	EA	2
47	70	PAHZZ	5310-00-045-3299	MS35338-42	96906	WASHER LOCK	EA	15
47	71	PAHZZ	5310-00-809-8544	MS27183-7	96906	WASHER, FLAT	EA	15
47	72	XDHZZ	5305-00-054-6668	MS51957-43	96906	SCREW, MACHINE	EA	15
47	73	PAHZZ	5310-00-596-8718	MS832-2	46384	FASTENER, CLINCH	EA	5
47	74	PAHZZ	5305-00-059-3660	MS51958-64	96906	SCREW, MACHINE	EA	4
47	75	PAHZZ	5310-00-929-6395	MS35338-136	96906	WASHER, LOCK	EA	1
47	76	PAHZZ	5305-00-054-6651	MS51957-27	96906	SCREW, MACHINE	EA	1
47	77	PAHZZ	5310-00-531-9514	AN960C6	88044	WASHER, FLAT	EA	1

122/(123 blank)

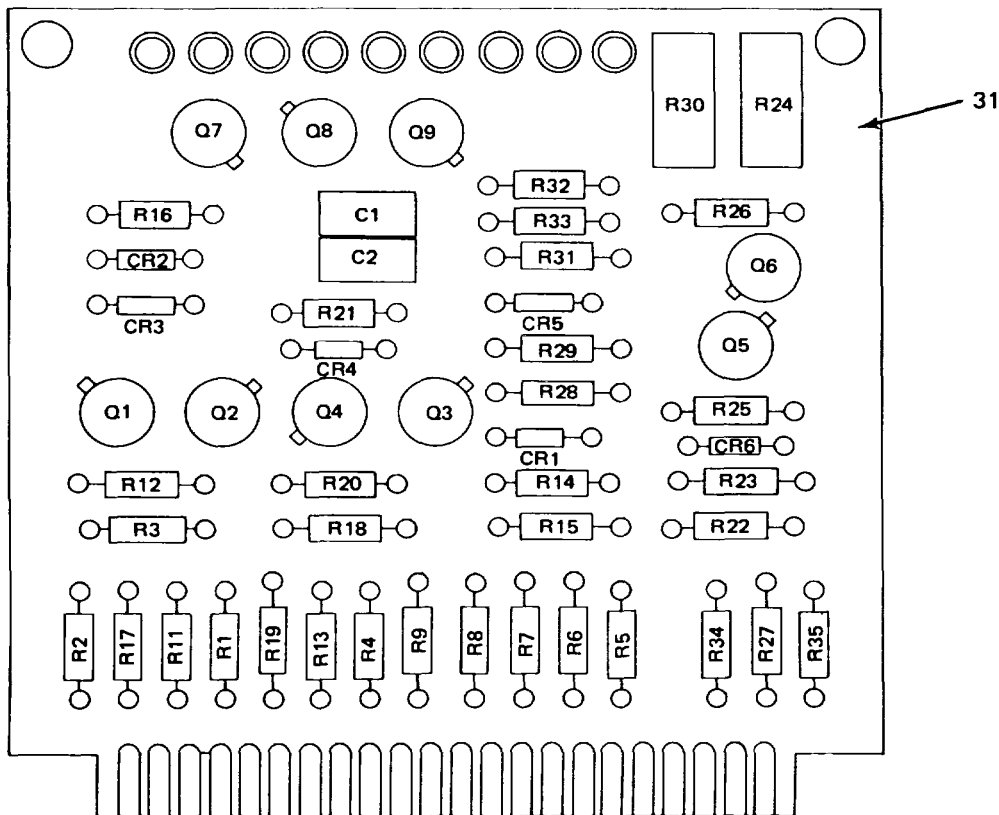

REF. DES.	ITEM NO.	REF. DES.	ITEM NO.	REF. DES.	ITEM NO.
C1	2	R1	8	R19	17
C2	1	R2	9	R20	18
CR1	3	R3	10	R21	19
CR2	4	R4	11	R22	20
CR3	4	R5	11	R23	21
CR4	4	R6	11	R24	22
CR5	5	R7	11	R25	23
CR6	5	R8	11	R26	24
Q1	6	R9	11	R27	25
Q2	7	R11	8	R28	26
Q3	7	R12	12	R29	27
Q4	6	R13	9	R30	22
Q5	6	R14	13	R31	28
Q6	6	R15	11	R32	12
Q7	6	R16	14	R33	29
Q8	6	R17	15	R34	30
Q9	7	R18	16	R35	23

NOTE: PREFIX ALL REFERENCE DESIGNATIONS WITH PS1A1

EL00M055

Figure 48. Circuit Card Assembly PS1A1.

SECTION II

TM 11-7440-222-40P/NAVELEX 0967-LP-324-0480/TO 31W4-2G-84

(1) ILLUSTRATION		(2)	(3)	(4)	(5)	(6) DESCRIPTION	(7)	(8)
(a) FIG NO.	(b) ITEM NO.	SMR CODE	NATIONAL STOCK NUMBER	PART NUMBER	FSCM	USABLE ON CODE	U/M	QTY INC IN UNIT
						GROUP 0601 CIRCUIT CARD ASSEMBLY PS1A1		
48	1	XDDZZ		75F1R1B472	03508	CAPACITOR, FXD, PAPER	EA	1
48	2	XDDZZ		75F3R18104	03508	CAPACITOR, FXD, PAPER	EA	1
48	3	PADDZZ	5961-00-892-1009	1N9638	81349	SEMICONDUCTOR, DIODE	EA	1
48	4	PADZZ	5961-00-107-0748	A14BX280	03508	SEMICONDUCTOR DEVIC.....	EA	3
48	5	PADZZ	5961-00-081-6103	1N823	81349	SEMICONDUCTOR, DIODE	EA	2
48	6	PADZZ	5961-00-852-5171	2N1711	81349	TRANSISTOR.....	EA	6
48	7	PADZZ	5961-00-949-1440	2N29D5	81349	TRANSISTOR.....	EA	3
48	8	PADZZ	5905-00-279-3512	RC20GF431J	81349	RESISTOR, FIXED, COMP	EA	1
48	9	PADZZ	5905-00-195-6806	RC20GF102J	81349	RESISTOR, FIXED, COMP	EA	2
48	10	PADZZ	5905-00-190-8887	RC20GF202J	81349	RESISTOR, FIXED, COMP	EA	1
48	11	PADZZ	5905-00-232-7180	RN60D1960F	81349	RESISTOR, FIXED, FILM.....	EA	7
48	12	PADZZ	5905-00-781-8015	RN6003480F	81349	RESISTOR, FIXED, FILM.....	EA	2
48	13	PADZZ	5905-00-279-3517	RC20GF510J	81349	RESISTOR, FIXED, COMP	EA	1
48	14	PADZZ	5905-00-279-1157	RC20GF152J	81349	RESISTOR, FIXED, COMP	EA	1
48	15	PADZZ	5905-00-279-3506	RC20GF332J	81349	RESISTOR, FIXED, COMP	EA	1
48	16	PADZZ	5905-00-069-3914	RN60D1961F	81349	RESISTOR, FXED, FILM.....	EA	1
48	17	PADZZ	5905-00-763-6457	RN60D1152F	81349	RESISTOR, FIXED, FILM.....	EA	1
48	18	PADZZ	5905-00-279-3505	RC20GF392J	81349	RESISTOR, FIXED, COMP	EA	1
48	19	PADZZ	5905-00-192-3973	RC20GF471J	81349	RESISTOR, FIXED, COMP	EA	1
48	20	PADZZ	5905-00-985-4889	RN60D8250F	81349	RESISTOR, FIXED, FILM.....	EA	1
48	21	PADZZ	5905-00-952-7042	RN60D2610F	81349	RESISTOR, FIXED, FILM.....	EA	1
48	22	PADZZ	5905-00-107-0813	77PR500	73138	RESISTOR, VARIABLE.....	EA	2
48	23	PADZZ	5905-00-988-2313	RN60D1211F	81349	RESISTOR, FIXED, FILM.....	EA	2
48	24	PADZZ	5905-00-050-7598	R460D1401F	81349	RESISTOR, FIXED, FILM.....	EA	1
48	25	PADZZ	5905-00-957-0643	RN60D4640F	81349	RESISTOR, FIXED, FILM.....	EA	1
48	26	PADZZ	5905-00-988-2317	RN60D1001F	81349	RESISTOR, FIXED, FILM.....	EA	1
48	27	PADZZ	5905-00-954-4642	RN60D1621F	81349	RESISTOR, FIXED, FILM.....	EA	1
48	28	PADZZ	5905-00-761-1901	RN60D2151F	81349	RESISTOR, FIXED, FILM.....	EA	1
48	29	PADZZ	5905-00-965-5554	RN60D6810F	81349	RESISTOR, FIXED, FILM.....	EA	1
48	30	PADZZ	5905-00-104-8337	RC201GF51J	81349	RESISTOR, FIXED, COMP	EA	1
48	31	XDDZZ		40-000006-1	06809	PRINTED CIRCUIT BD	EA	1
					125			

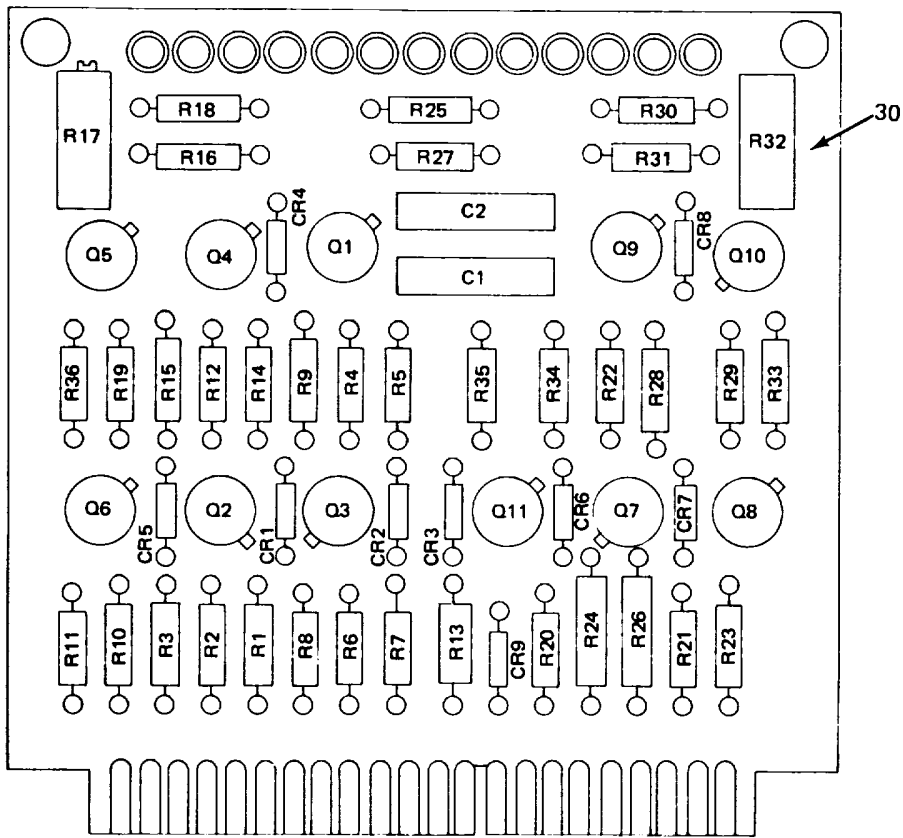

REF. DES.	ITEM NO.	REF. DES.	ITEM NO.	REF. DES.	ITEM NO.	REF. DES.	ITEM NO.	REF. DES.	ITEM NO.	REF. DES.	ITEM NO.	REF. DES.	ITEM NO.
C1	1	CR8	4	Q8	8	R6	12	R15	20	R24	26	R33	21
C2	2	CR9	5	Q9	8	R7	13	R16	21	R25	27	R34	10
CR1	3	Q1	7	Q10	8	R8	14	R17	22	R26	26	R35	25
CR2	3	Q2	8	Q11	8	R9	15	R18	21	R27	28	R36	25
CR3	3	Q3	7	R1	9	R10	16	R19	10	R28	18		
CR4	4	Q4	7	R2	9	R11	12	R20	23	R29	19		
CR5	5	Q5	7	R3	9	R12	17	R21	24	R30	29		
CR6	3	Q6	8	R4	10	R13	18	R22	25	R31	21		
CR7	6	Q7	7	R5	11	R14	19	R23	9	R32	22		

NOTE: PREFIX ALL REFERENCE DESIGNATIONS WITH PS1A2

EL0QM056

Figure 49. Circuit Card Assembly PS1A2.

SECTION II

TM 11-7440-222-40P/NAVELEX 0967-LP-324-0480/TO 31W4-2G-84

(1) ILLUSTRATION		(2)	(3)	(4)	(5)	(6) DESCRIPTION	(7)	(8)
(a) FIG NO.	(b) ITEM NO.	SMR CODE	NATIONAL STOCK NUMBER	PART NUMBER	FSCM	USABLE ON CODE	U/M	QTY INC IN UNIT
						GROUP 0602 CIRCUIT CARD ASSEMBLY PS1A2		
49	1	XDDZZ		75F2R1B473	03508	CAPACITOR, ELCTLT	EA	1
49	2	XDDZZ		75F3R1B104	03508	CAPACITOR, FIXED, PAPER	EA	1
49	3	PADZZ	5961-00-107-0748	A14BX280	03508	SEMICONDUCTOR DEVIC.....	EA	4
49	4	PADZZ	5961-00-081-6103	1N823	81349	SEMICONDUCTOR, DIODE	EA	2
49	5	PADZZ	5961-00-107-0819	40809	98675	SEMICONDUCTOR DEVIC.....	EA	2
49	6	PADZZ	5961-00-088-8792	1N5059	80131	SEMICONDUCTOR, DIODE	EA	1
49	7	PADZZ	5961-00-852-5171	2NT1711	81349	TRANSISTOR.....	EA	5
49	8	PADZZ	5961-00-949-1440	2N2905	81349	TRANSISTOR.....	EA	6
49	9	PADZZ	5905-00-957-0643	RN60D4640F	81349	RESISTOR, FIXED, FILM.....	EA	4
49	10	PADZZ	5905-00-171-2006	RC20GF271J	81349	RESISTOR, FIXED, COMP.....	EA	3
49	11	PADZZ	5905-00-219-1757	RC20GF152J	81349	RESISTOR, FIXED, COMP.....	EA	1
49	12	PADZZ	5905-00-279-3504	RC20GF472J	81349	RESISTOR, FIXED, COMP.....	EA	2
49	13	PADZZ	5905-00-781-8015	RN60D3480F	81349	RESISTOR, FIXED, FILM.....	EA	1
49	14	PADZZ	5905-00-190-8887	RC20GF202J	81349	RESISTOR, FIXED, COMP.....	EA	1
49	15	PADZZ	5905-00-984-1465	RN60D0562F	81349	RESISTOR, FIXED, FILM.....	EA	1
49	16	PADZZ	5905-00-985-5435	RN60D7501F	81349	RESISTOR, FIXED, FILM.....	EA	1
49	17	PADZZ	5905-00-279-1889	RC20GF361J	81349	RESISTOR, FIXED, COMP.....	EA	1
49	18	PADZZ	5905-00-952-9230	RN60D7500F	81349	RESISTOR, FIXED, FILM.....	EA	2
49	19	PADZZ	5905-00-195-6806	RC20GF102J	81349	RESISTOR, FIXED, COMP.....	EA	2
49	20	PADZZ	5905-00-954-4642	RN60D1621F	81349	RESISTOR, FIXED, FILM.....	EA	1
49	21	PADZZ	5905-00-840-7609	RN60C1871F	81349	RESISTOR, FIXED, FILM.....	EA	4
49	22	PADZZ	5905-00-107-0818	77PR500	73138	RESISTOR, VARIABLE.....	EA	2
49	23	PADZZ	5905-00-279-3517	RC20GF510J	81349	RESISTOR, FIXED, COMP.....	EA	1
49	24	PADZZ	5905-00-192-3973	RC2DGF411J	81349	RESISTOR, FIXED, COMP.....	EA	1
49	25	PADZZ	5905-00-190-8889	RC20GF101J	81349	RESISTOR, FIXED, COMP.....	EA	3
49	26	PADZZ	5905-00-542-9387	RW59V102	81349	RESISTOR, FIXED, WIRE	EA	2
49	27	PADZZ	5905-00-051-8003	RN60D1582F	81349	RESISTOR, FXD, FILM.....	EA	1
49	28	PADZZ	5905-00-116-8568	RC20GF752J	81349	RESISTOR, FIXED, COMP.....	EA	1
49	29	PADZZ	5905-00-069-3914	RN60D01961F	81349	RESISTOR, FIXED, FILM.....	EA	1
49	30	XDDZZ		40-00009-1	06809	PRINTED CIRCUIT BD	EA	1
					127			

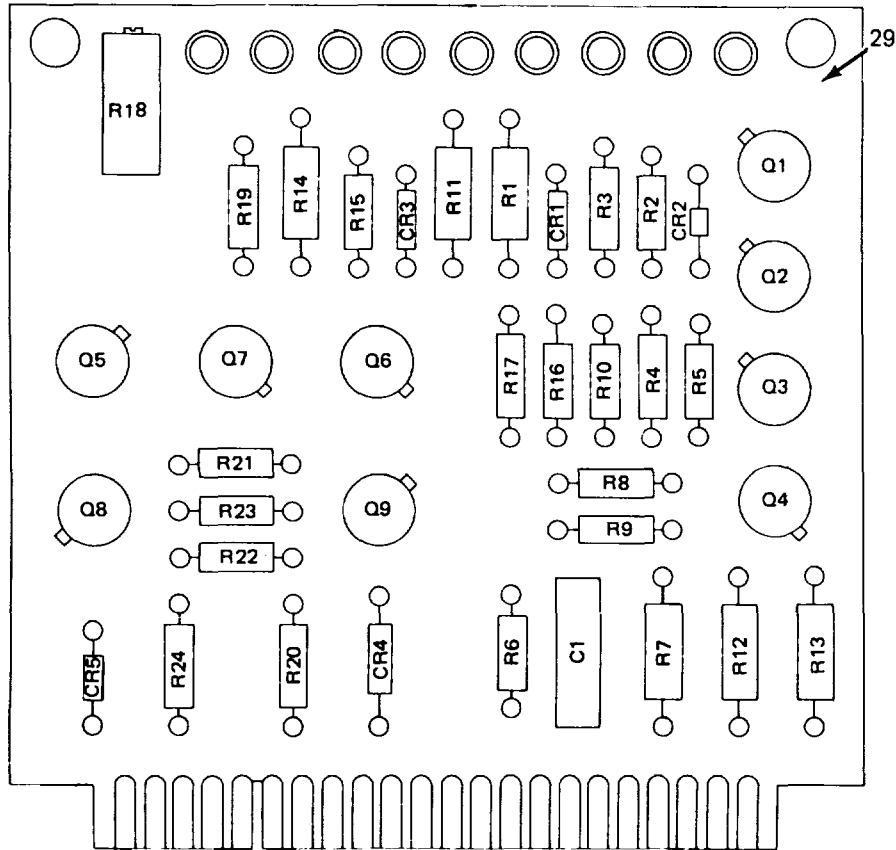

REF. DES.	ITEM NO.	REF. DES.	ITEM NO.	REF. DES.	ITEM NO.	REF. DES.	ITEM NO.	REF. DES.	ITEM NO.	REF. DES.	ITEM NO.	REF. DES.	ITEM NO.
C1	1	Q1	6	Q7	8	R4	13	R10	17	R16	21	R22	26
CR1	2	Q2	7	Q8	8	R5	14	R11	18	R17	22	R23	27
CR2	3	Q3	7	Q9	9	R6	15	R12	16	R18	23	R24	28
CR3	4	Q4	8	R1	10	R7	16	R13	16	R19	24		
CR4	5	Q5	8	R2	11	R8	15	R14	19	R20	25		
CR5	2	Q6	8	R3	12	R9	17	R15	20	R21	14		

NOTE: PREFIX ALL REFERENCE DESIGNATIONS WITH PS1A3

ELOQM057

Figure 50. Circuit Card Assembly PS1A3.

SECTION II

TM 11-7440-222-40P/NAVELEX 0967-LP-324-0480/TO 31W4-2G-84

(1) ILLUSTRATION		(2)	(3)	(4)	(5)	(6) DESCRIPTION	(7)	(8)
(a) FIG NO.	(b) ITEM NO.	SMR CODE	NATIONAL STOCK NUMBER	PART NUMBER	FSCM	USABLE ON CODE	U/M	QTY INC IN UNIT
						GROUP 0603 CIRCUIT CARD ASSEMBLY PS1A3		
50	1	XDDZZ		75F2R8473	03508	CAPACITOR, ELCTLT	EA	1
50	2	PADZZ	5961-00-107-0820	40-000126-1	12436	SEMICONDUCTOR DEVIC.....	EA	2
50	3	PADZZ	5961-00-107-0748	A14BX280	03508	SEMICONDUCTOR DEVIC.....	EA	1
50	4	XDDZZ		1N942	81349	SEMICONDUCTOR, DIODE	EA	1
50	5	XDDZZ		1N3022A	81349	SEMICONDUCTOR, DIODE	EA	1
50	6	PADZZ	5961-00-949-1440	2N2905	81349	TRANSISTOR.....	EA	1
50	7	PADZZ	5961-00-852-5171	2N1711	81349	TRANSISTOR.....	EA	2
50	8	PADZZ	5961-00-949-1440	2N2905A	81349	TRANSISTOR.....	EA	5
50	9	PADZZ	5961-00-133-2884	2N2243A	80131	TRANSISTOR.....	EA	1
50	10	PADZZ	5905-00-676-7410	RW59V182	81349	RESISTOR, FIXED, WIRE	EA	1
50	11	PADZZ	5905-00-279-1757	RC20GF152J	81349	RESISTOR, FIXED, COMP	EA	1
50	12	PADZZ	5905-00-952-2148	RN6003011F	81349	RESISTOR, FIXED, FILM.....	EA	1
50	13	PADZZ	5905-00-969-5854	RN0D5620F	81349	RESISTOR, FIXED, FILM.....	EA	1
50	14	PADZZ	5905-00-111-8357	RC0GF681J	81349	RESISTOR, FIXED, COMP	EA	2
50	15	PADZZ	5905-00-192-3973	RC20GF471J	81349	RESISTOR, FIXED, COMP	EA	2
50	16	PADZZ	5905-00-578-0997	RW59V102	81349	RESISTOR, FIXED, WIRE	EA	3
50	17	PADZZ	5905-00-279-2616	RC20GF153J	81349	RESISTOR, FIXED, COMP	EA	2
50	18	PADZZ	5905-00-689-5771	3X3000	63743	RESISTOR, FXD, WW	EA	1
50	19	PADZZ	5905-00-088-0635	RW69V471	81349	RESISTOR, FIXED, WIRE	EA	1
50	20	PADZZ	5905-00-190-8887	RC20GF202J	81349	RESISTOR, FIXED, COMP	EA	1
50	21	PADZZ	5905-00-069-3916	RN60D3831F	81349	RESISTOR, FIXED, FILM.....	EA	1
50	22	PADZZ	5905-00-686-3380	RN6DC2871F	81349	RESTSTOR, FIXED, FILM.....	EA	1
50	23	PADZZ	5905-00-107-0818	77PR500	73138	RESISTOR, VARIABLE	EA	1
50	24	PADZZ	5905-00-781-4857	RN60D9531F	81349	RESISTOR, FIXED, FILM.....	EA	1
50	25	PADZZ	5905-00-952-6023	RN6003162F	81349	RESISTOR, FIXED, FILM.....	EA	1
50	26	PADZZ	5905-00-116-8568	RC20GF752J	81349	RESISTOR, FIXED, COMP	EA	1
50	27	PADZZ	5905-00-185-8510	RC20GF103J	81349	RESISTOR, FIXED, COMP	EA	1
50	28	PADZZ	5905-00-952-2146	RN60D5111F	81349	RESISTOR, FIXED, FILM.....	EA	1
50	29	XDDZZ		40-000012-1	06809	PRINTED CIRCUIT BD	EA	1
					129			

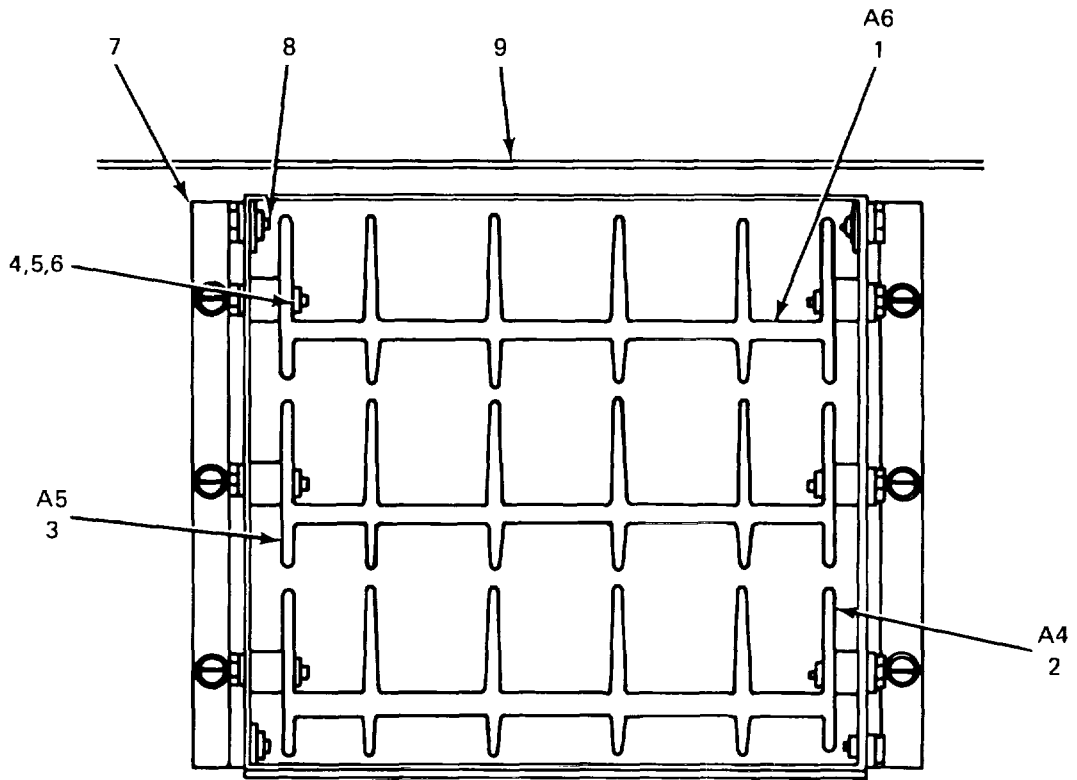

NOTE: PREFIX ALL REFERENCE DESIGNATIONS WITH PS1A11

EL0QM058

Figure 51. Heat Sink Assembly PS1A11.

SECTION II

TM 11-7440-222-40P/NAVELEX 0967-LP-324-0480/TO 31W4-2G-84

(1) ILLUSTRATION		(2)	(3)	(4)	(5)	(6)	(7)	(8)
(a) FIG NO.	(b) ITEM NO.	SMR CODE	NATIONAL STOCK NUMBER	PART NUMBER	FSCM	DESCRIPTION USABLE ON CODE	U/M	QTY INC IN UNIT
						GROUP 0604 HEAT SINK ASSEMBLY PS1A11		
51	1	XDHHH		40-000045-1	06809	HEATSINK ASSEMBLY	EA	1
51	2	XDHHH		40-000042-1	06809	HEATSINK SUBASSY.....	EA	1
51	3	XDHHH		40-000039-1	06809	HEATSINK ASSEMBLY	EA	1
51	4	PAHZZ	5305-00-054-6657	MS51957-33	96906	SCREW, MACHINE.....	EA	6
51	5	PAHZZ	5310-00-983-8483	MS15795-205	96906	WASHER, FLAT	EA	10
51	6	PAHZZ	5310-00-198-3724	MS35337-41	96906	WASHER, LOCK	EA	10
51	7	XDHZZ		40-000015-1	06809	COVER, SIDE	EA	2
51	8	PAHZZ	5305-00-054-6654	MS51957-30	96906	SCREW, MACHINE.....	EA	4
51	9	XDHZZ		40-000017-1	06809	END PLATE.....	EA	2
					131			

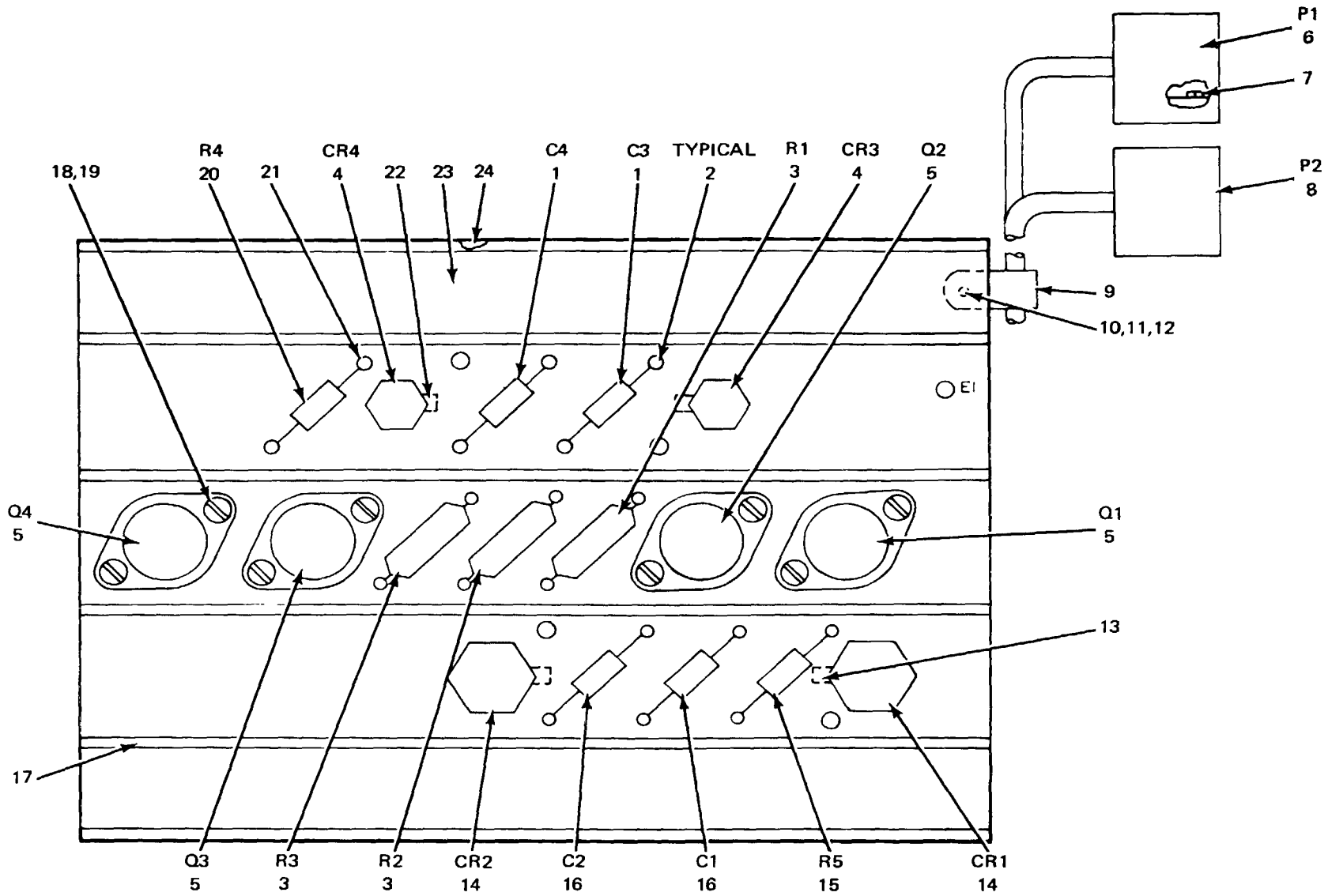

NOTE: PREFIX ALL REFERENCE DESIGNATIONS WITH PS1A4

EL0QM059

Figure 52. Heat Sink Subassembly PS1A4.

SECTION II

TM 11-7440-222-40P/NAVELEX 0967-LP-324-0480/TO 31W4-2G-84

(1) ILLUSTRATION		(2)	(3)	(4)	(5)	(6) DESCRIPTION	(7)	(8)
(a) FIG NO.	(b) ITEM NO.	SMR CODE	NATIONAL STOCK NUMBER	PART NUMBER	FSCM	USABLE ON CODE	U/M	QTY INC IN UNIT
						GROUP 060401 HEAT SINK SUBASSEMBLY PS1A4		
52	1	XDHZZ		75F1R28103	03508	CAPACITOR FXD, PAPER	EA	2
52	2	XDHZZ	5940-00-935-8246	206-29F	86571	TERMINAL, STUD.....	EA	3
52	3	PAHZZ	5905-00-902-7456	RW57GR20	81349	RESISTOR, FIXED, WIRE	EA	3
52	4	PAHZZ	5961-00-226-3717	1N12002	81349	SEMICONDUCTOR DEVIC.....	EA	2
52	5	PAHZZ	5961-00-199-6008	2N3055	81349	TRANSISTOR.....	EA	4
52	6	PAHZZ	5935-00-102-0130	1-480278-5	00779	CONNECTOR BODY, RECE.....	EA	1
52	7	PAHZZ	5999-00-104-8551	61118-1	00779	CONTACT, ELECTRICAL	EA	10
52	8	PAHZZ	5935-00-102-0131	1-480278-6	00779	CONNECTOR BODY, RECE.....	EA	1
52	9	PAHZZ	5340-00-003-9207	HP-4N	09922	CLAMP, CABLE	EA	1
52	10	PAHZZ	5305-00-054-5653	MS51957-19	96906	SCREW, MACHINE.....	EA	1
52	11	PAHZZ	5310-00-043-1754	MS35337-79	96906	WASHER, LOCK	EA	1
52	12	PAHZZ	5310-00-983-8483	MS15795-205	96906	WASHER, FLAT	EA	9
52	13	PAHZZ	5940-00-736-3719	34113	00779	TERMINAL, LUG	EA	2
52	14	PAHZZ	5961-00-752-5395	1N1184	81349	SEMICONDUCTOR, DIODE	EA	2
52	15	PAHZZ	5905-00-892-0349	RW59V151	81349	RESISTOR, FIXED, WIRE	EA	1
52	16	XDHZZ		75F1R18103	03508	CAPACITOR, FXD, PAPER	EA	2
52	17	XDHHH		40-000097-1	06809	HEATSINK.....	EA	1
52	18	PAHZZ	5305-00-054-6653	MS51957-29	96906	SCREW, MACHINE.....	EA	1
52	19	PAHZZ	5310-00-929-6395	MS535337-79	96906	WASHER, LOCK	EA	1
52	20	PAHZZ	5905-00-226-7626	3X6000	63743	RESISTOR, FIXED, WIRE	EA	1
52	21	XDHZZ	5940-00-935-8248	FTSM66L4	98291	TERMINAL, LUG	EA	12
52	22	PAHZZ	5940-00-501-5859	34112	00779	TERMINAL, LUG	EA	2
52	23	XDHZZ		400M0004-1	06809	EXTRUSION.....	EA	3
52	24	PAHZZ	5310-00-803-4994	CLS632-3	46384	NUT, PLAIN, CLINCH.....	EA	4
					133			

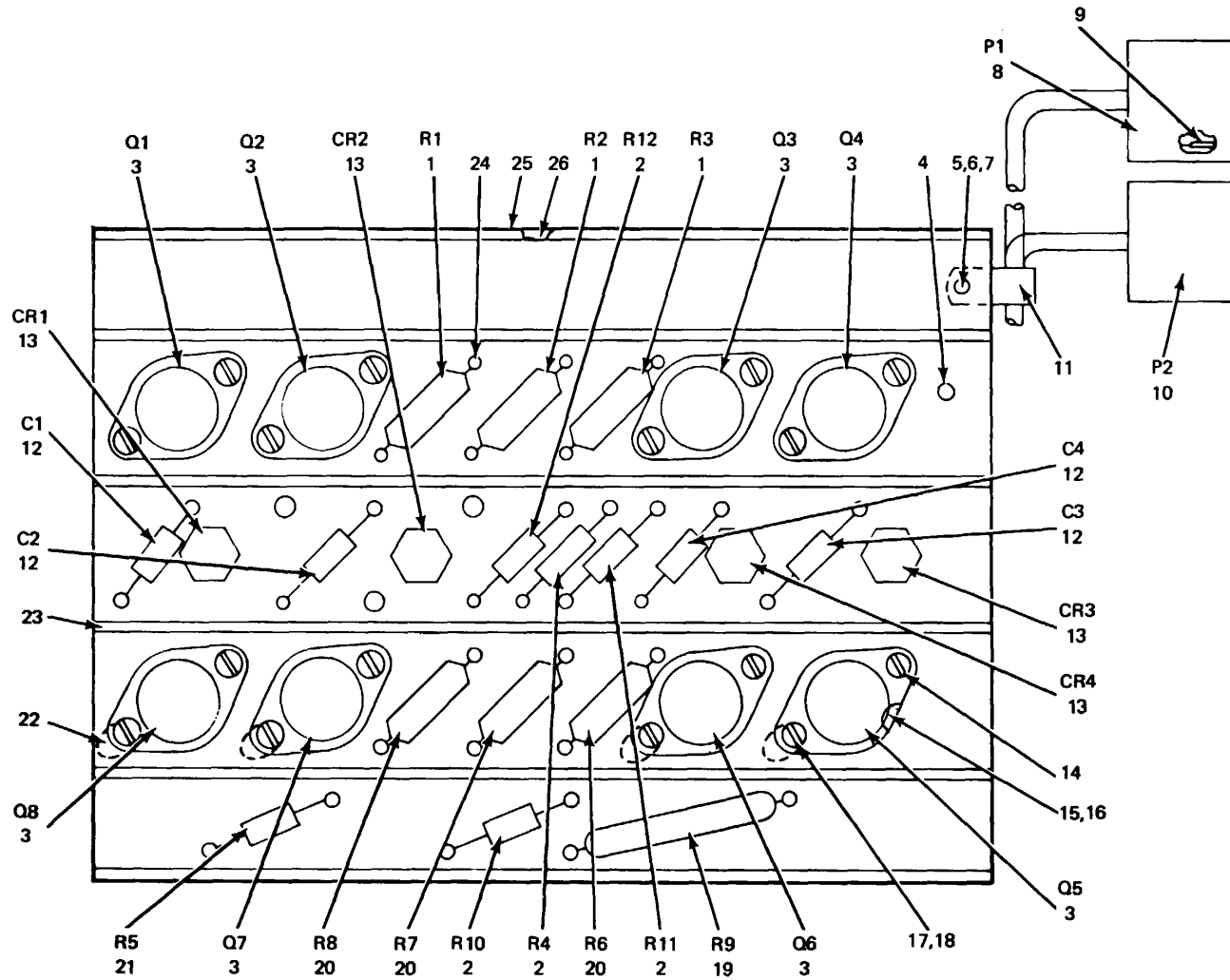

NOTE: PREFIX ALL REFERENCE DESIGNATIONS WITH PS1A5

ELOQM060

Figure 53. Heat Sink Assembly PS1A5

SECTION II

TM 11-7440-222-40P/NAVELEX 0967-LP-324-0480/TO 31W4-2G-84

(1) ILLUSTRATION		(2)	(3)	(4)	(5)	(6) DESCRIPTION	(7)	(8)
(a) FIG NO.	(b) ITEM NO.	SMR CODE	NATIONAL STOCK NUMBER	PART NUMBER	FSCM	USABLE ON CODE	U/M	QTY INC IN UNIT
						GROUP 060402 HEAT SINK ASSEMBLY PS1A5		
53	1	PAHZZ	5905-00-902-7456	RW57GR20	81349	RESISTOR, FIXED, WIRE	EA	3
53	2	PAHZZ	5905-00-088-0636	RW59V601	81349	RESISTOR, FIXED, WIRE	EA	4
53	3	PAHZZ	5961-00-199-6008	2N3055	81349	TRANSISTOR.....	EA	8
53	4	XDHZZ	5940-00-935-8246	2D6-29F	86517	TERMINAL,STUD.....	EA	1
53	5	PAHZZ	5305-00-054-6653	MS51957-29	96906	SCREW, MACHINE.....	EA	9
53	6	PAHZZ	5310-00-983-8483	MS5795-205	96906	WASHER, FLAT	EA	9
53	7	PAHZZ	5310-00-045-4007	MS35337-22	96906	WASHER, LOCK	EA	9
53	8	PAHZZ	5935-00-102-0129	1-480278-2	00779	CONNECTOR B0DY, RECE	EA	1
53	9	PAHZZ	5999-00-104 8551	61118-1	00779	CONTACT, ELECTRICAL	EA	10
53	10	PAHZZ	5935-00-050-5307	1-480278-3	00779	CONNECTOR, BODY, RECE.....	EA	1
53	11	PAHZZ	5340-00-003-9207	HP-4N	09922	CLAMP, LOOP	EA	1
53	12	XDHZZ		75F1R1B103	03508	CAPACITOR, FXD, PPR	EA	4
52	13	PADZZ	5310-00-935-0138	1N1200	81349	SEMICONDUCTOR DEVIC.....	EA	4
53	14	PAHZZ	5305-00-054-6654	MS51957-30	96906	SCREW, MACHINE.....	EA	8
53	15	XDHZZ	5970-00-097-9580	DM103SL	08289	INSULATOR, PLATER	EA	5
53	16	XDHZZ		MW375-140	08289	INSULATOR, WASHER	EA	7
53	17	XDHZZ		40-00111-1	06809	BUSHING	EA	16
53	18	PAHZZ	5310-00-934-9761	MS35649-264	96906	NUT, PLAIN, HEXAGON.....	EA	8
53	19	XDHZZ		5VR2T	81349	RESISTOR, FXD, WW	EA	1
53	20	PAHZZ	5905-00-781-9660	RW67YR33	81349	RESISTOR, FXD, WW	EA	3
53	21	PAHZZ	5905-00-577-7427	RW59V-100	81349	RESISTOR	EA	1
53	22	PAHZZ	5940-00-682-2477	505	79963	TERMINAL, LUG	EA	4
53	23	XDHZZ		40-000030-1	06809	HEATSINK.....	EA	1
53	24	XDHZZ	5940-00-935-0248	FTSM66L4	98291	TERMINAL, FEEDTHRU, I.....	EA	1
53	25	XDHZZ		40-00004-1	06809	EXTRUSION.....	EA	1
53	26	PAHZZ	5310-00-803-4994	CLS632-3	46384	NUT, PLAIN, CLINCH.....	EA	
					135			

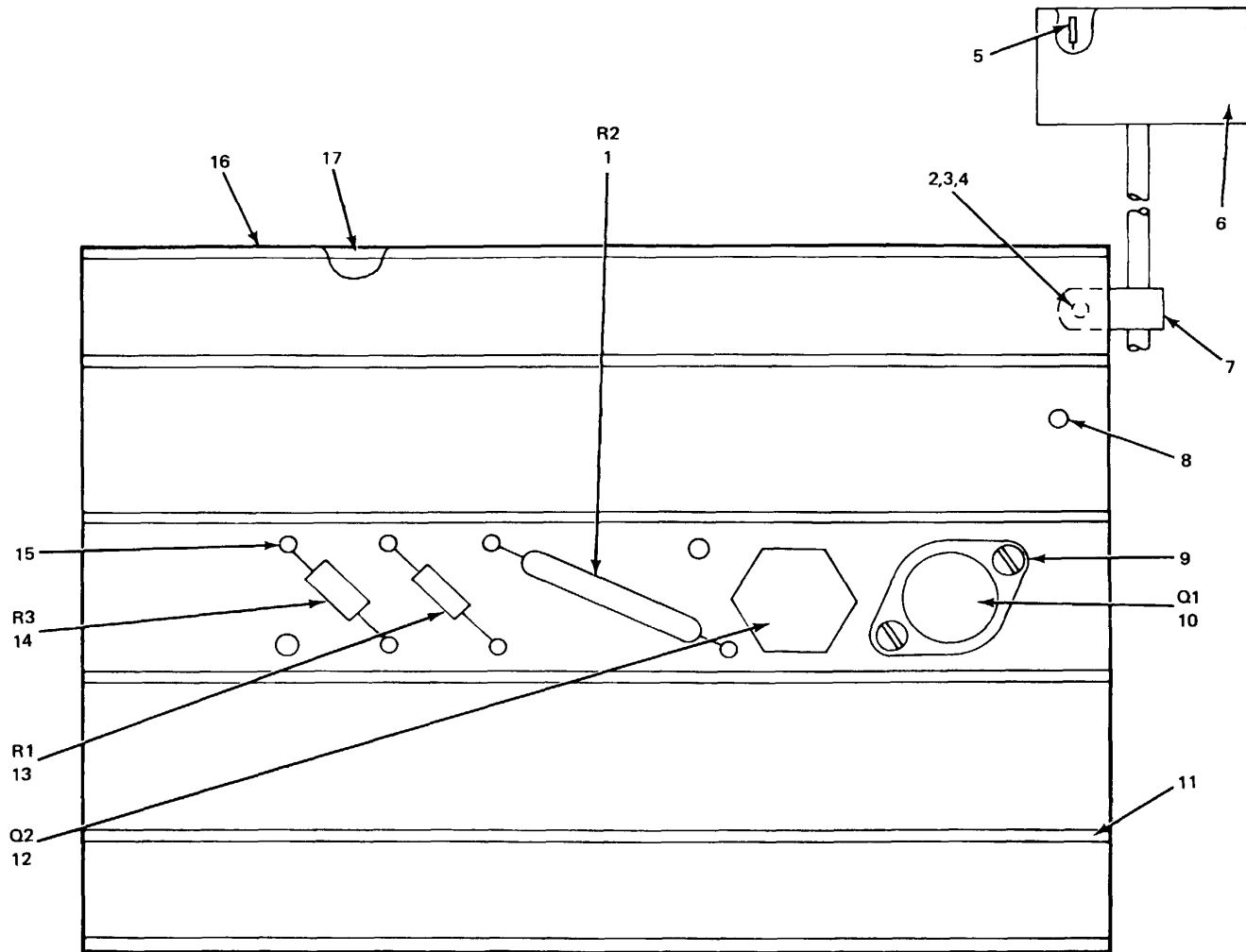

NOTE: PREFIX ALL REFERENCE DESIGNATIONS WITH PS1A6

EL00M061

Figure 54. Heat Sink Assembly PS1A6.

SECTION II

TM 11-7440-222-40P/NAVELEX 0967-LP-324-0480/TO 31W4-2G-84

(1) ILLUSTRATION		(2)	(3)	(4)	(5)	(6) DESCRIPTION	(7)	(8)
(a) FIG NO.	(b) ITEM NO.	SMR CODE	NATIONAL STOCK NUMBER	PART NUMBER	FSCM	USABLE ON CODE	U/M	QTY INC IN UNIT
						GROUP 060403 HEAT SINK ASSEMBLY PS1A6		
54	1	XDHZZ		RWSBVR27	81349	RESISTOR, FXD, WW	EA	1
54	2	PAHZZ	5310-00-929-6395	MS35337-79	96906	WASHER, LOCK	EA	3
54	3	PAHZZ	5310-00-983-8483	MS15795-205	96906	WASHER, FLAT	EA	1
54	4	PAHZZ	5305-00-054-6653	MS51957-29	96906	SCREW, MACHINE	EA	3
54	5	XDHZZ	5999-00-104-8551	61118-1	00779	CONTACT, ELECTRICAL	EA	13
54	6	PAHZZ	5935-00-054-4172	1-460278-9	00779	CONNECTOR BODY, RECE.....	EA	1
54	7	PAHZZ	5340-00-003-9207	HP-4N	09922	CLAMP, LOOP	EA	1
54	8	XDHZZ	5940-00-935-8246	2D6-29F	86577	TERMINAL, STUD.....	EA	1
54	9	PAHZZ	5310-00-809-8546	MS15795-208	96906	WASHER, FLAT	EA	2
54	10	PAHZZ	5961-00-712-5578	JAN2N3442	81349	TRANSISTOR.....	EA	1
54	11	XDHHH		38939	98675	HEATSINK.....	EA	1
54	12	PAHZZ	5961-00-999-7351	164-10	-05277	TRANSISTOR.....	EA	1
54	13	PAHZZ	5905-00-081-6137	RW69V5R1	81349	RESISTOR, FXD, WW	EA	1
54	14	PAHZZ	5905-00-088-0636	RWS9V601	81349	RESISTOR, F[XED, WIRE	EA	1
54	15	XDHZZ	5940-00-935-8248	FTSM66L4	98291	TERMINAL, FEEDTHRU, I.....	EA	6
54	16	XDHZZ		40-000004-1	06809	EXTRUSION.....	EA	1
54	17	PAHZZ	5310-00-803-4994	CLS632-3	46384	NUT, PLAIN, CLINCH.....	EA	1
					137			

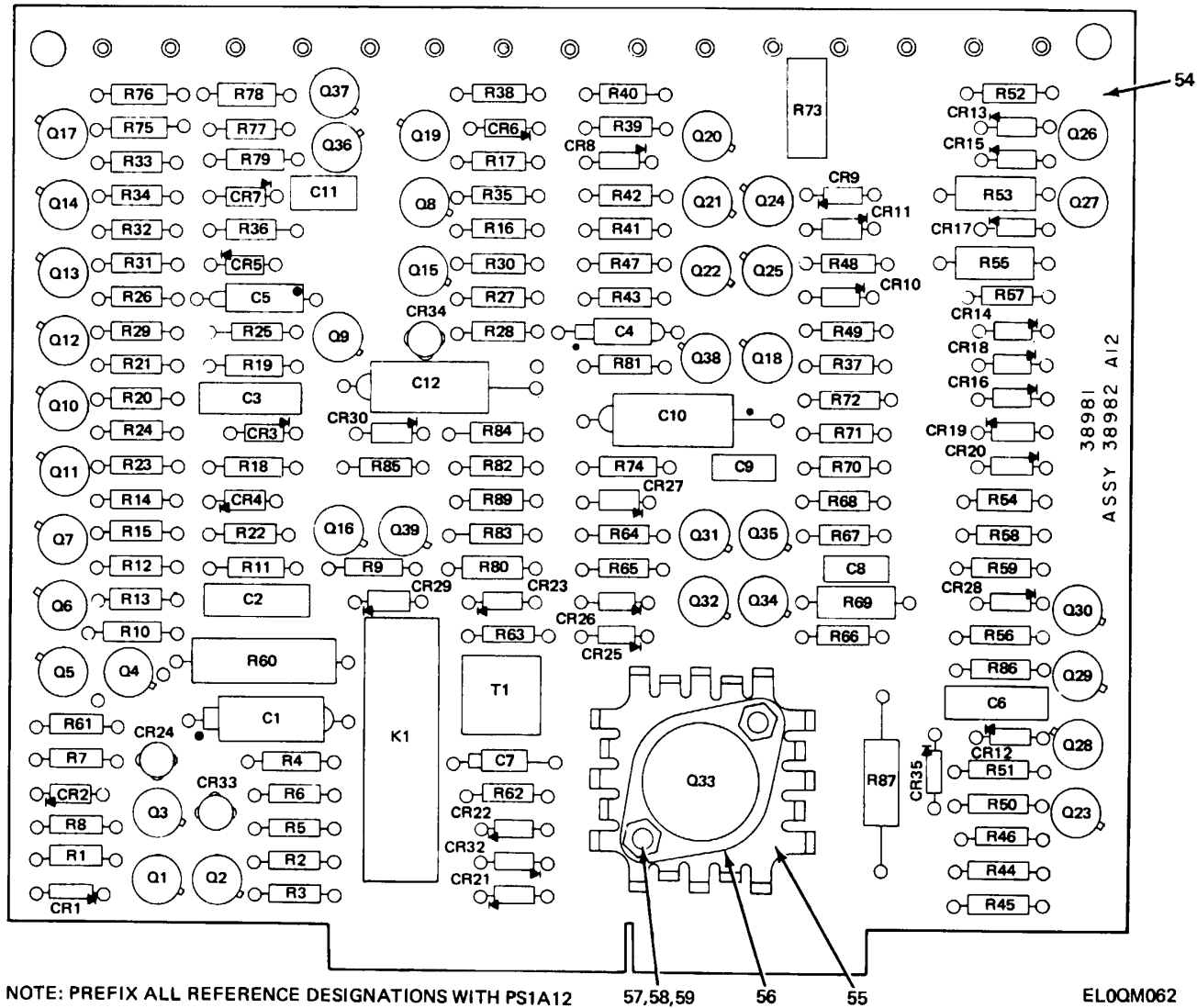

Figure 55. Circuit Card Assembly PS1A12 (Sheet 1 of 3).

REF. DES.	ITEM NO.	REF. DES.	ITEM NO.	REF. DES.	ITEM NO.	REF. DES.	ITEM NO.	REF. REF.	ITEM NO.	REF. DES.	ITEM NO.	REF. DES.	ITEM NO.
C1	1	CR7	7	CR25	7	Q8	15	Q26	15	R5	19	R23	28
C2	2	CR8	7	CR26	7	Q9	15	Q27	15	R6	21	R24	19
C3	2	CR9	7	CR27	10	Q10	14	Q28	14	R7	22	R25	28
C4	3	CR10	7	CR28	7	Q11	14	Q29	14	R8	23	R26	30
C5	3	CR11	7	CR29	7	Q12	14	Q30	14	R9	24	R27	18
C6	2	CR12	7	CR30	10	Q13	14	Q31	15	R10	25	R28	17
C7	4	CR13	7	CR32	7	Q14	14	Q32	13	R11	26	R29	17
C8	5	CR14	7	CR33	11	Q15	15	Q33	16	R12	19	R30	18
C9	5	CR15	7	CR34	11	Q16	14	Q34	14	R13	26	R31	31
C10	6	CR16	7	CR35	7	Q17	14	Q35	14	R14	19	R32	28
C11	5	CR17	7	K1	12	Q18	14	Q36	14	R15	27	R33	28
C12	6	CR18	7	Q1	13	Q19	15	Q37	14	R16	19	R34	17
CR1	7	CR19	7	Q2	14	Q20	15	Q38	15	R17	28		
CR2	7	CR20	7	Q3	15	Q21	15	Q39	14	R18	29		
CR3	7	CR21	7	Q4	15	Q22	15	R1	17	R19	20		
CR4	7	CR22	7	Q5	14	Q23	14	R2	18	R20	18		
CR5	8	CR23	7	Q6	14	Q24	15	R3	19	R21	19		
CR6	7	CR24	9	Q7	14	Q25	15	R4	20	R22	28		

ELOQM063

Figure 55. Circuit Card Assembly PS1A12 (Sheet 2 of 3).

REF. DES.	ITEM NO.	REF. DES.	ITEM NO.	REF. DES.	ITEM NO.
R35	32	R54	28	R73	47
R36	27	R55	38	R74	46
R37	19	R56	39	R75	48
R38	19	R57	19	R76	24
R39	30	R58	28	R77	49
R40	19	R59	40	R78	20
R41	18	R60	41	R79	24
R42	19	R61	32	R80	24
R43	33	R62	31	R81	19
R44	34	R63	42	R82	28
R45	35	R64	33	R83	18
R46	18	R65	43	R84	50
R47	19	R66	17	R85	28
R48	18	R67	44	R86	51
R49	19	R68	18	R87	52
R50	36	R69	45	R89	20
R51	37	R70	22	T1	53
R52	19	R71	28		
R53	38	R72	46		

ELOQM064

Figure 55. Circuit Card Assembly PS1A12 (Sheet 3 of 3).

SECTION II

TM 11-7440-222-40P/NAVELEX 0967-LP-324-0480/TO 31W4-2G-84

(1) ILLUSTRATION		(2)	(3)	(4)	(5)	(6) DESCRIPTION	(7)	(8)
(a) FIG NO.	(b) ITEM NO.	SMR CODE	NATIONAL STOCK NUMBER	PART NUMBER	FSCM	USABLE ON CODE	U/M	QTY INC IN UNIT
						GROUP 0605 CIRCUIT CARD ASSEMBLY PS1A12		
55	1	PADZZ	5910-00-779-8404	CSL3BE107K	81349	CAPACITOR FIXED ELE	EA	1
55	2	XDDZZ		75F3R18104	03508	CAPACITOR, FXD, PAPER	EA	3
55	3	PADZZ	5910-00-782-1973	CS138E106K	81349	CAPACITOR, FIXED, ELE	EA	2
55	4	PADZZ	5910-00-787-2109	CS13BF105K	81349	CAPACITOR, ELCTLT	EA	1
55	5	XDDZZ		75F1R1B103	03508	CAPACITOR, FXD, PAPER	EA	3
55	6	PADZZ	5910-00-087-9000	CL65BG181MP3	81349	CAPACITOR, ELCTLT	EA	2
55	7	PADZZ	5961-00-088-8792	1N5059	80131	SEMICONDUCTOR, DIODE	EA	28
55	8	PADZZ	5961-00-938-1135	1N4148	81349	SEMICONDUCTOR, DIODE	EA	1
55	9	PADZZ	5961-00-901-7586	2N2323	81349	SEMICONDUCTOR, DIODE	EA	1
55	10	PADZZ	5961-00-852-7549	1N754A	81349	SEMICONDUCTOR, DIODE	EA	2
55	11	PADZZ	5961-00-244-6905	2N4986	80131	SEMICONDUCTOR, DIODE	EA	2
55	12	PADZZ	5945-00-107-0747	CR120G900A02	02295	RELAY.....	EA	1
55	13	XDDZZ		2N2243N	81349	TRANSISTOR.....	EA	2
55	14	PADZZ	5961-00-852-5171	2N1711	81349	TRANSISTOR.....	EA	21
55	15	PADZZ	5961-00-949-1440	2N2905A	81349	TRANSISTOR.....	EA	15
55	16	PADZZ	5961-00-199-6008	2N3055	81349	TRANSISTOR.....	EA	1
55	17	PADZZ	5905-00-195-6806	RC20GF102J	81349	RESISTOR, FIXED, COMP.....	EA	5
55	18	PADZZ	5905-00-279-3504	RC20GF472J	81349	RESISTOR, FIXED, COMP.....	EA	9
55	19	PADZZ	5905-00-111-8357	RC200GF681J	81349	RESISTOR, FIXED, COMP.....	EA	16
55	20	PADZZ	5905-00-079-3561	RN6003481F	81349	RESISTOR, FIXED, FILM.....	EA	4
55	21	PADZZ	5905-00-299-1541	RC20GF1S1J	81349	RESISTOR FIXED C	EA	1
55	22	PADZZ	5905-00-192-3913	RC20GF471J	81349	RESISTOR, FIXED, COMP.....	EA	2
55	23	PADZZ	5905-00-252-4018	RC2GF7J	81349	RESISTOR, FIXED, COMP.....	EA	1
55	24	PADZZ	5905-00-984-1465	RN60D5621F	81349	RESISTOR, FIXED, FILM.....	EA	4
55	25	PADZZ	5905-00-834-2968	RN60C1T81F	81349	RESISTOR, FIXED, FILM.....	EA	1
55	26	PADZZ	5905-00-279-1757	RC20GF152J	81349	RESISTOR, FIXED, COMP.....	EA	2
55	27	PADZZ	5905-00-279-2616	RC20GF153J	81349	RESISTOR, FIXED, COMP.....	EA	2
55	28	PADZZ	5905-00-279-3506	RC20GF332J	81349	RESISTOR, FIXED, COMP.....	EA	11
55	29	PADZZ	5905-00-954-4642	RN60D1621F	81349	RESISTOR, FIXED, FILM.....	EA	1
55	30	PADZZ	5905-00-279-1876	RC20GF222J	81349	RESISTOR, FIXED, COMP.....	EA	2
55	31	PADZZ	5905-00-106-1282	RC20GF223J	81349	RESISTOR, FIXED, COMP.....	EA	2
55	32	PADZZ	5905-00-104-8310	RC20GF221J	81349	RESISTOR, FIXED, COMP.....	EA	2
55	33	PADZZ	5905-00-185-8510	RC20GF3J	81349	RESISTOR, FIXED, COMP.....	EA	2
55	34	PADZZ	5905-00-983-6914	RN60D1002F	81349	RESISTOR, FIXED, FILM.....	EA	1
55	35	PADZZ	5905-00-078-293	R60D1821F	81349	RESISTOR, FIXED, FILM.....	EA	1
55	36	XDDZZ		RN60DL21F	81349	RESISTOR, FXD, FILM.....	EA	
55	37	PADZZ	5905-00-043-0381	RN6002211F	81349	RESISTOR, FIXED, FILM.....	EA	1
55	38	PADZZ	5905-00-892-0349	RW59V151	81349	RESISTOR, FIXED, WIRE	EA	2
55	39	PADZZ	5905-00-763-6457	RN60D1152F	81349	RESISTOR, FIXED, FILM.....	EA	1
					141			

SECTION II

TM 11-7440-222-40P/NAVELEX 0967-LP-324-0408/TO 31W4-2G-84

(1) ILLUSTRATION		(2)	(3)	(4)	(5)	(6) DESCRIPTION	(7)	(8)
(a) FIG NO.	(b) ITEM NO.	SMR CODE	NATIONAL STOCK NUMBER	PART NUMBER	FSCM	USABLE ON CODE	U/M	QTY INC IN UNIT
55	40	PADZZ	5905-00-752-7228	RN60C11782F	81349	RESISTOR, FIXED, FILM.....	EA	1
55	41	PADZZ	5905-00-504-4640	RW57V301	81349	RESISTOR, FIXED, WIRE.....	EA	1
55	42	PADZZ	5905-00-279-3521	RC20GF150J	81349	RESISTOR, FIXED, COMP.....	EA	1
55	43	PADZZ	5905-00-192-3971	RC20GF331J	81349	RESISTOR, FIXED, COMP.....	EA	1
55	44	PADZZ	5905-00-190-8889	RC20GF101J	81349	RESISTOR, FIXED, COMP.....	EA	1
55	45	PADZZ	5905-00-577-9574	RW59V2R2	81349	RESISTOR, FIXED, WIRE.....	EA	1
55	46	PADZZ	5905-00-761-1901	N60D2151F	81349	RESISTOR, FIXED, FILM.....	EA	2
55	47	PADZZ	5905-00-107-0818	77PR500	73138	RESISTOR, VARIABLE, N.....	EA	1
55	48	PADZZ	5905-00-051-8003	RN60D1582F	81349	RESISTOR, FIXED, FILM.....	EA	1
55	49	PADZZ	5905-00-988-2313	RN60D1211F	81349	RESISTOR, FIXED, FILM.....	EA	1
55	50	PADZZ	5905-00-731-8315	RN60D1402F	81349	RESISTOR, FIXED, FILM.....	EA	1
55	51	PADZZ	5905-00-952-6024	RN60D3482F	81349	RESISTOR, FIXED, FILM.....	EA	1
55	52	XDDZZ	5905-00- 865-0361	RW79U5621F	81349	RESISTOR, FXD, WW.....	EA	1
55	53	PADZZ	5950-00-102-8133	4000133-1	12436	TRANSFORMER, ELECTRI.....	EA	1
55	54	XDDZZ		40-000050-1	06809	PRINTED CKT BOARD.....	EA	1
55	55	XDDZZ		4000167-1	06809	HEATSINK.....	EA	1
55	56	XDDZZ	5970-00-097-9580	DM103SL	08289	INSULATOR, PLATE.....	EA	1
55	57	PADZZ	5310-00-934-9761	MS35649-264	96906	NUT, PLAIN, HEXAGON.....	EA	2
55	58	PADZZ	5305-00-054-6652	MS51957-28	96906	SCREW, MACHINE.....	EA	2
55	59	PADZZ	5310-00-929-6395	MS35338-136	96906	WASHER, LOCK.....	EA	2
142/(143 blank)								

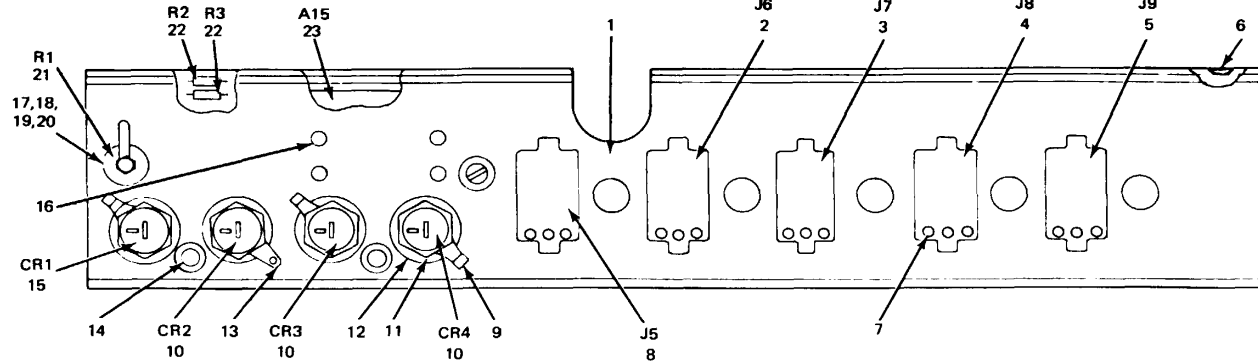

CONNECTOR BRACKET ASSEMBLY

NOTE: PREFIX ALL REFERENCE DESIGNATIONS WITH PS1A14

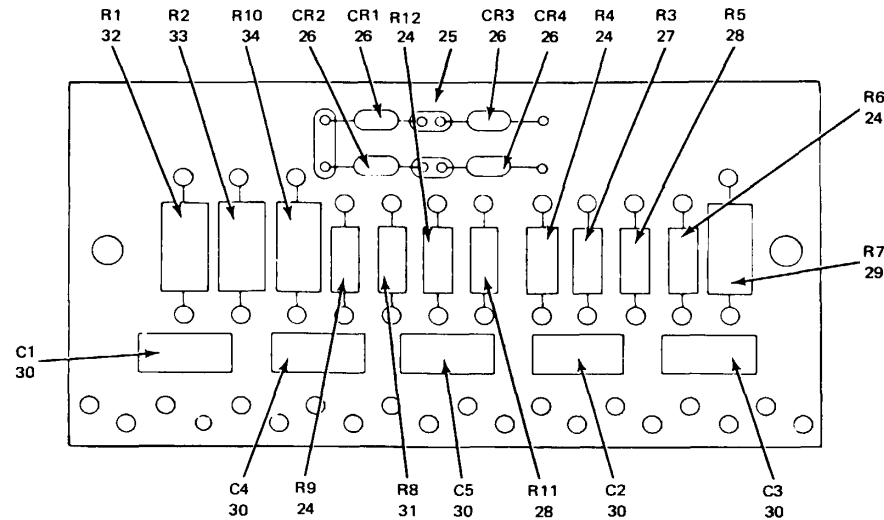

CIRCUIT CARD ASSEMBLY

NOTE: PREFIX ALL REFERENCE DESIGNATIONS WITH A1A15

ELOQM065

Figure 56. Connector Bracket Assembly PS1A14 and Circuit Card Assembly A1A15.

SECTION II

TM 11-7440-222-40P/NAVELEX 0967-LP-324-0408/TO 31W4-2G-84

(1) ILLUSTRATION		(2)	(3)	(4)	(5)	(6) DESCRIPTION	(7)	(8)
(a) FIG NO.	(b) ITEM NO.	SMR CODE	NATIONAL STOCK NUMBER	PART NUMBER	FSCM	USABLE ON CODE	U/M	QTY INC IN UNIT
						GROUP 0606 CONNECTOR BRACKET ASSEMBLY PS1A14		
56	1	XDHHH		40-000109-1	06809	BRACKET, CONNECTOR.....	EA	1
56	2	PAHZZ	5935-00-137-7303	1-4802756	00779	CONNECTOR BODY, PLUG.....	EA	1
56	3	PAHZZ	5935-00-137-7300	1-80275-2	00779	CONNECTOR BODY, PLUG.....	EA	1
56	4	PAHZZ	5935-00-137-7301	1-480275-3	00779	CONNECTOR BODY, PLUG.....	EA	1
56	5	PAHZZ	5935-00-451-7385	1-480275-9	00779	CONNECTOR BODY, RECE.....	EA	1
56	6	PAHZZ	5310-00-596-8131	5632-2	46384	NUT, PLAIN, CLINCH.....	EA	2
56	7	PAHZZ	5999-00-76-6327	61117-1	00779	CONTACT, ELECTRICAL.....	EA	15
56	8	PAHZZ	5935-00-137-7302	1-480275-5	00779	CONNECTOR BODY, PLUG.....	EA	1
56	9	PAHZZ	5940-00-736-3719	34113	00779	TERMINAL, LUG.....	EA	3
56	10	PAHZZ	5961-00-846-5808	2N682	81349	SEMICONDUCTOR.....	EA	3
56	11	XDHZZ		NM750-255	08289	INSULATOR, WASHER.....	EA	8
56	12	XDHZZ		TRU516-25	08289	SPACER.....	EA	4
56	13	PAHZZ	5940-00-552-3635	29A	199613	TERMINAL, LUG.....	EA	1
56	14	XDHZZ		A240	57771	EYELET, FLANGE.....	EA	2
56	15	PAHZZ	5961-00-060-6817	JAN2N683	80131	SEMICONDUCTOR.....	EA	1
56	16	XDHZZ		FTSK6614	98291	TERMINAL STUD.....	EA	4
56	17	XDHZZ		40-000182-1	06809	WASHER, SHOULDER.....	EA	2
56	18	PAHZZ	5310-00-198-3724	MS535337-41	96906	WASHER, LOCK.....	EA	1
56	19	PAHZZ	5310-00-082-1404	MS27183-6	96906	WASHER, FLAT.....	EA	1
56	20	XDHZZ		40-000199-11	06809	SCREW, MACHINE.....	EA	1
56	21	XDHZZ		RFV219W2	63743	RESISTOR, FXD, WW.....	EA	1
56	22	XDHZZ		RW57GR10	81349	RESISTOR, FXD, WW.....	EA	2
56	23	PAHDL	7040-00-018-9690	40-000113-1	12436	CIRCUIT CARD ASSEMB.....	EA	1
						GROUP 060601 CIRCUIT CARD ASSEMBLY A1A15		
56	24	PADZZ	5905-00-171-2006	RC20GF271J	81349	RESISTOR, FIXED, COMP.....	EA	4
56	25	XDDZZ		40-00011-1	06809	PRINTED CKT BOARD.....	EA	1
56	26	PADZZ	5961-00-088-8792	1N5059	80131	SEMICONDUCTOR, DIODE.....	EA	4
56	27	PADZZ	5905-00-111-8357	RC20GF681J	81349	RESISTOR, FIXED, COMP.....	EA	1
56	28	PADZZ	5905-00-190-8889	RC20GF101J	81349	RESISTOR, FIXED, COMP.....	EA	2
56	29	PADZZ	5905-00-855-2219	RW59V101	81349	RESISTOR, FIXED, WIRE.....	EA	1
56	30	XDDZZ		75F1R1B103	03508	CAPACITOR, FXD, PAPER.....	EA	5
56	31	PADZZ	5905-00-279-3518	RC20GF300J	81349	RESISTOR, FIXED, COMP.....	EA	1
56	32	PADZZ	5905-00-578-0997	RW59V202	81349	RESISTOR, FIXED, WIRE.....	EA	1
56	33	PADZZ	5905-00-978-7703	RW59V1R5	81349	RESISTOR, FIXED, WIRE.....	EA	1
56	34	PADZZ	5905-00-088-0636	RW59V601	81349	RESISTOR, FIXED, WIRE.....	EA	1
					145			

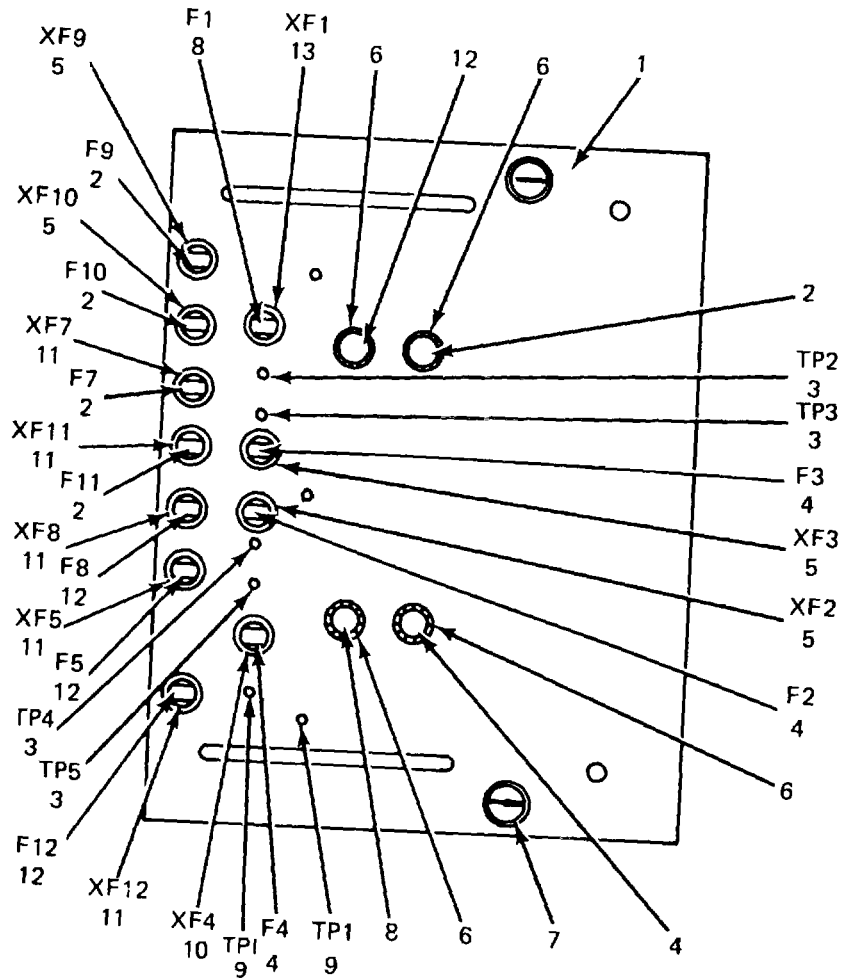

NOTE: PREFIX ALL REFERENCE DESIGNATIONS WITH PS1A10

ELOQM066

Figure 57. Front Panel Assembly PS1A10.

SECTION II

(1) ILLUSTRATION		(2)	(3)	(4)	(5)	(6) DESCRIPTION	(7)	(8)
(a) FIG NO.	(b) ITEM NO.	SMR CODE	NATIONAL STOCK NUMBER	PART NUMBER	FSCM	USABLE ON CODE	U/M	QTY INC IN UNIT
						GROUP 0607 FRONT PANEL ASSEMBLY PS1A10		
57	1	XDHXX		40-000066	06809	FRONT PANEL	EA	1
57	2	PAHZZ	5920-00-583-8486	F038125V3A	81349	FUSE, CARTRIDGE	EA	5
57	3	PAHZZ	5935-00-615-6742	SKT58CGRN	98291	JACK, TIP	EA	4
57	4	PAHZZ	5920-00-280-5002	F3A250V010A	81349	FUSE, CARTRIDGE	EA	4
57	5	PAHZZ	5920-00-952-5360	FHL18G1-1	71400	FUSEHOLDER, EXTRACTO.....	EA	4
57	6	PAHZZ	5920-00-636-0970	HKP-A	71400	FUSEHOLDER, EXTRACTO.....	EA	4
57	7	PAHZZ	5340-00-684-9956	49-1-1-0	94222	LATCH.....	EA	2
57	8	PAHZZ	5920-00-199-9502	F03A250V15A	81349	FUSE, CARTRIDGE	EA	2
57	9	XDHZZ	5935-00-615-6736	SKT5BCBLK	98291	JACK, TIP	EA	1
57	10	PAHZZ	5920-00-269-3743	FHL1BG1-5	71400	FUSEHOLDER, EXTRACTO.....	EA	1
57	11	XDHZZ	HKL-X	71400	FUSEH	FUSEHOLDER.....	EA	5
57	12	PAHZZ	5920-00-342-5828	MDA10A250V	71400	FUSE, CARTRIDGE	EA	4
57	13	PAHZZ	5920-00-043-1425	FHL18G1-9	71400	FUSEHOLDER, EXTRACTO.....	EA	1
					147			

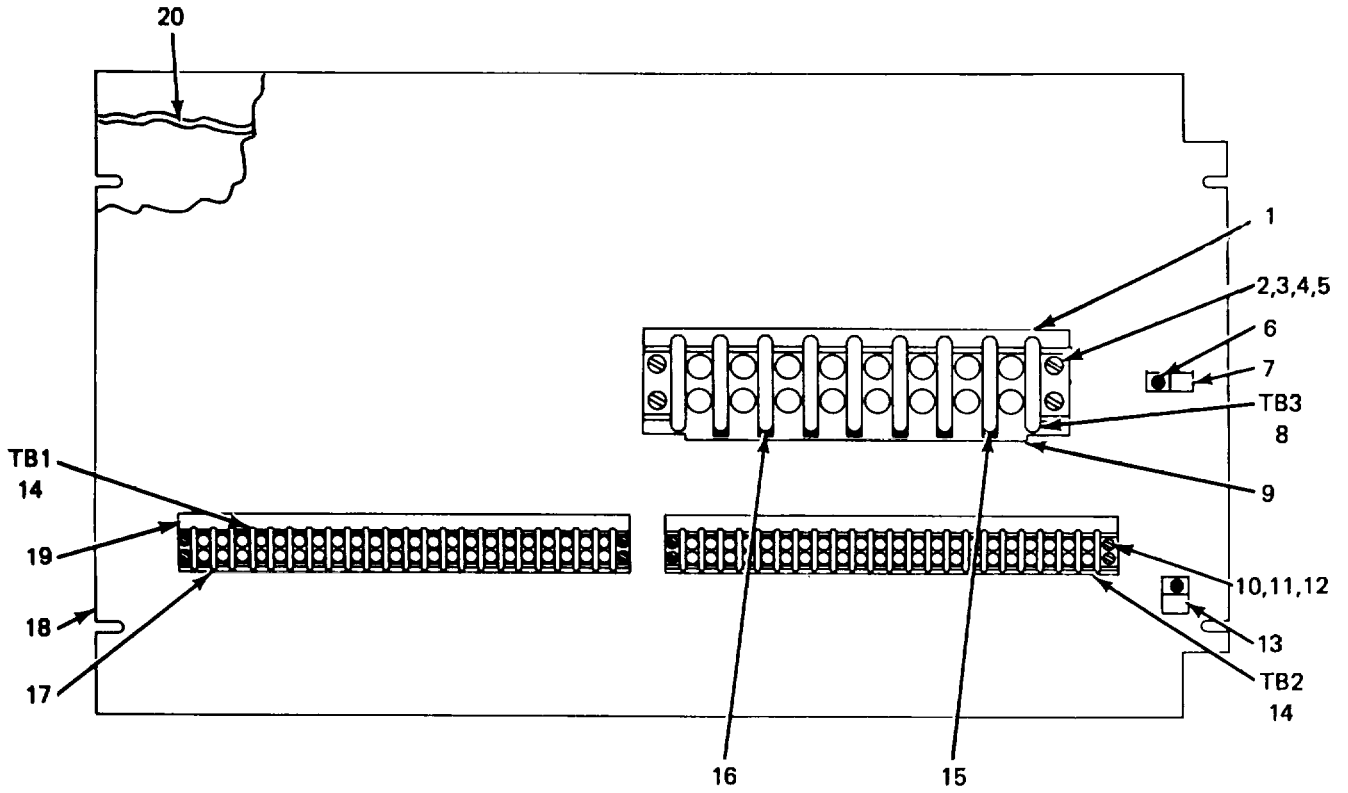

INTERFACE PLATE

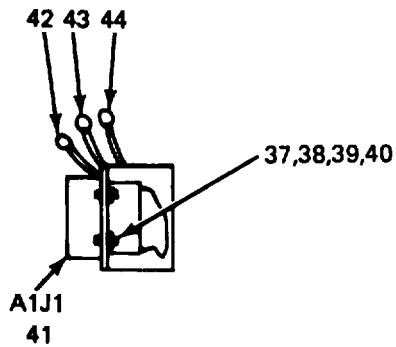

CONNECTOR

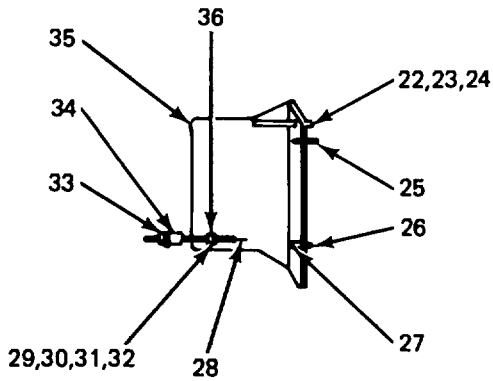

BRACKET

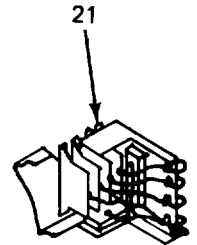

CONTACT ASSEMBLY

EL0QM067

Figure 58. Plate, Interface and Wiring Harness (A65405-001).

SECTION II

TM 11-7440-222-40P/NAVELEX 0967-LP-324-0408/TO 31W4-2G-84

(1) ILLUSTRATION		(2)	(3)	(4)	(5)	(6) DESCRIPTION	(7)	(8)
(a) FIG NO.	(b) ITEM NO.	SMR CODE	NATIONAL STOCK NUMBER	PART NUMBER	FSCM	USABLE ON CODE	U/M	QTY INC IN UNIT
						GROUP 07 PLATE, INTERFACE		
58	1	XDHZZ		MS604-8XXXP1C	75382	MARKER, STRIP.....	EA	1
58	2	PAHZZ	5305-00-054-6672	MS51957-47	96906	SCREW, MACHINE.....	EA	4
58	3	PAHZZ	5310-00-933-8119	MS35338-137	96906	WASHER, LOCK.....	EA	4
58	4	PAHZZ	5310-00-558-6207	AN960C8L	88044	WASHER, FLAT.....	EA	4
58	5	PAHZZ	5310-00-934-9759	MS35649-284	96906	NUT, PLAIN, HEXAGON.....	EA	4
58	6	PAHZZ	5305-00-054-6671	MS51957-46	96906	SCREW, MACHINE.....	EA	1
58	7	XDHZZ	5340-00-515-0136	HP18N	09922	CLAMP, LOOP.....	EA	2
58	8	XDHZZ		604C8UH	75382	TERMINAL BOARD.....	EA	1
58	9	XDHZZ		640RJ8	75382	JUMPER SERIES.....	EA	1
58	10	PAHZZ	5305-00-054-6654	MS51957-30	96906	SCREW, MACHINE.....	EA	8
58	11	PAHZZ	5310-00-929-6395	MS35338-136	96906	WASHER, LOCK.....	EA	8
58	12	PAHZZ	5310-00-934-9761	MS35649-264	96906	NUT, PLAIN, HEXAGON.....	EA	8
58	13	XDHZZ	5340-00-560-9262	HP13N	09922	CLAMP, LOOP.....	EA	2
58	14	XDHZZ		600C-22UH	75382	TERMINAL BOARD.....	EA	2
58	15	XDHZZ	5940-00-660-3631	MS25036-50	96906	TERMINAL, LUG.....	EA	8
58	16	XDHZZ	5940-00-557-4346	MS25036-16	96906	TERMINAL, LUG.....	EA	1
58	17	PAHZZ	5940-00-813-0698	MS25036-1	96906	TERMINAL, LUG.....	EA	44
58	18	XDHZZ		A61665-002	58189	PLATE, INTERFACE.....	EA	1
58	19	XDHZZ		MS600-22XXXP4D	75382	MARKER, STRIP.....	EA	2
58	20	XDHHH		A65405-001	58189	WIRING HARNESS.....	EA	1
						GROUP 0701 WIRING HARNESS (A65405-0011		
58	21	PAHHH	5999-00-933-5070	A53847-001	58189	CONTACT ASSEMBLY, EL.....	EA	1
58	22	XDHZZ		SMB546131	80063	SCREW, EXT RLV BODY.....	EA	1
58	23	PAHZZ	5310-00-638-9857	AN960C6L	88044	WASHER, FLAT.....	EA	1
58	24	PAHZZ	5310-00-929-6395	MS35338-136	96906	WASHER, LOCK.....	EA	1
58	25	XDHZZ		SNB546216	80063	PIN, KEYING.....	EA	1
58	26	PAHZZ	7440-00-019-3468	540362-06	16512	CONTACT, ELECTRICAL.....	EA	1
58	27	XDHZZ		P5500009-09	16512	INSULATOR, BUSHING.....	EA	1
58	28	PAHZZ	5940-00-993-5216	2-323930-2	00779	FERRULE, RADIO FREQU.....	EA	10
58	29	XDHZZ	5305-00-770-2580	MS51959-16	96906	SCREW, MACHINE.....	EA	1
58	30	PAHZZ	5310-00-933-811	N35338-135	96906	WASHER, LOCK.....	EA	1
58	31	PAHZZ	5310-00-782-1349	A960CI	88044	WASHER, FLAT.....	EA	1
58	32	PAHZZ	5310-00-271-4642	MS35649-44	96906	WASHER.....	EA	1
58	33	PAHZZ	5975-00-497-2158	MS1782-1-9	96906	STRAP, TIEDOWN, ELECT.....	EA	1
58	34	XDHZZ		TC25	59730	NAMEPLATE.....	EA	1
58	35	XDHZZ		5346-001	58189	BRACKET, ANGLE.....	EA	1
58	36	PAHZZ	5940-00-577-3711	NS25036-3	96906	TERMINAL, LUG.....	EA	1
58	37	PAHZZ	5310-00-934-9759	1135649-284	96906	NUT, PLAIN, HEXAGON.....	EA	2
58	38	PAHZZ	5310-00-685-3744	A960C	88044	WASHER, FLAT.....	EA	2

SECTION II

TM 11-7440-222-40P/NAVELEX 0967-LP-324-0480/TO 31W4-2G-84

(1) ILLUSTRATION		(2)	(3)	(4)	(5)	(6)	(7)	(8)
(a) FIG NO.	(b) ITEM NO.	SMR CODE	NATIONAL STOCK NUMBER	PART NUMBER	FSCM	DESCRIPTION USABLE ON CODE	U/M	QTY INC IN UNIT
58	39	PAHZZ	5310-00-93-8119	MS35338-137	96906	WASHER, LOCK	EA	2
58	40	PAHZZ	5305-00-054-6672	MS51957-47	96906	SCREW, MACHINE	EA	2
58	41	PAHZZ	5935-00-820-2080	MS3102R32-7S	96906	CONNECTOR, RECEPTACL	EA	1
58	42	PAHZZ	5940-00-204-9142	MS25036-12	96906	TERMINAL, LUG	EA	1
58	43	PAHZZ	5940-00-557-1627	MS25036-53	96906	TERMINAL, LUG	EA	3
58	44	PAHZZ	5940-00-557-1629	MS25036-49	96906	TERMINAL, LUG	EA	19
150/(151 blank)								

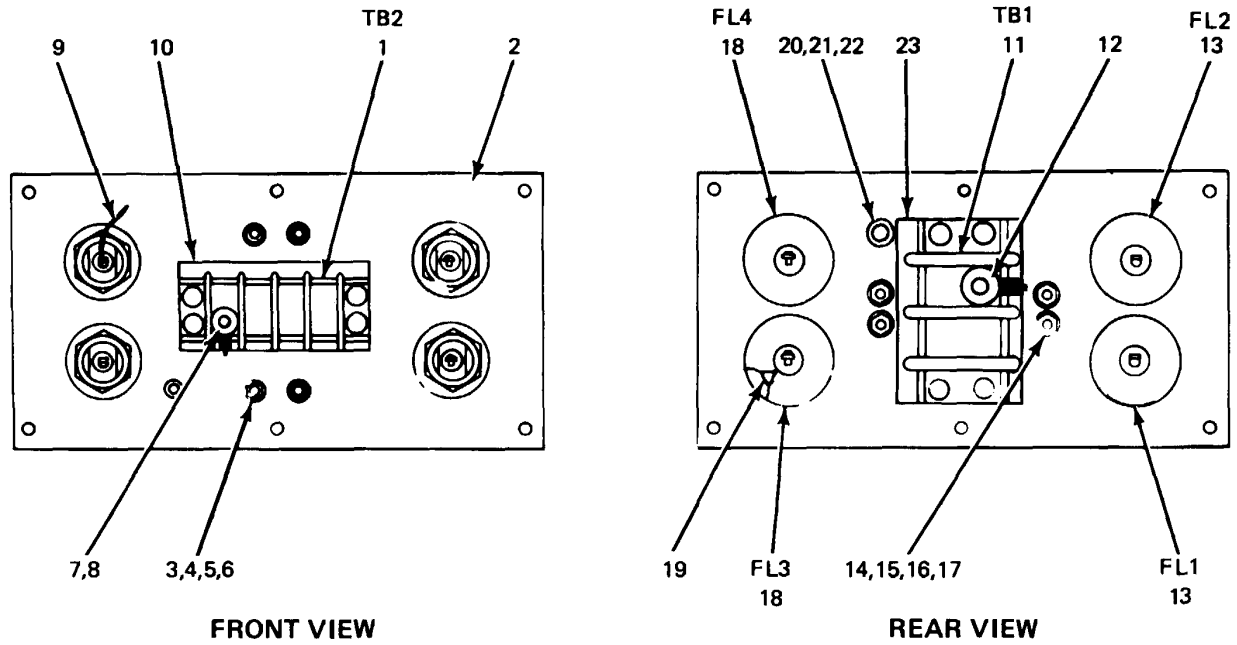

NOTE: PREFIX ALL REFERENCE DESIGNATIONS WITH FL1

ELOQM068

Figure 59. Filter Assembly.

SECTION II

(1) ILLUSTRATION		(2)	(3)	(4)	(5)	(6) DESCRIPTION	(7)	(8)
(a) FIG NO.	(b) ITEM NO.	SMR CODE	NATIONAL STOCK NUMBER	PART NUMBER	FSCM	USABLE ON CODE	U/M	QTY INC IN UNIT
						GROUP 08 FILTER ASSEMBLY		
59	1	XDHZZ		602C4UH	75382	TERMINAL BOARD.....	EA	1
59	2	XDHZZ		A64041-001	58189	PLATE ASSEMBLY.....	EA	1
59	3	PAHZZ	5305-00-054-6657	MS51957-33	96906	SCREW, MACHINE.....	EA	4
59	4	PAHZZ	5310-00-638-9857	AN960C6L	88044	WASHER, FLAT.....	EA	4
59	5	PAHZZ	5310-00-929-6395	MS35338-136	96906	WASHER, LOCK.....	EA	4
59	6	PAHZZ	5310-00-934-9761	MS35649-264	96906	NUT PLAIN, HEXAGON.....	EA	4
59	7	XDHZZ		MS25035-54	96906	TERMINAL, LUG.....	EA	2
59	8	PAHZZ	5940-00-557-1627	MS25036-53	96906	TERMINAL, LUG.....	EA	1
59	9	XDHZZ		A65132-002	58189	WIRING HARNESS.....	EA	1
59	10	XDHZZ		MS602-4XXXP4A	75382	STRIP, MARKER.....	EA	1
59	11	XDHZZ		604C2UH	75382	TERMINAL BOARD.....	EA	1
59	12	PAHZZ	5940-00-660-3634	MS25036-57	96906	TERMINAL, LUG.....	EA	2
59	13	PAHZZ	5915-00-905-1008	10JX63	56289	FILTER, RADIO FREQUE.....	EA	2
59	14	PAHZZ	5305-00-054-6673	MS51957-48	96906	SCREW, MACHINE.....	EA	4
59	15	PAHZZ	5310-00-558-6207	AN960CSL	88044	WASHER, FLAT.....	EA	4
59	16	PAHZZ	5310-00-933-8119	MS35338-137	96906	WASHER, LOCK.....	EA	4
59	17	PAHZZ	5310-00-934-9759	MS35649-284	96906	NUT, PLAIN, HEXAGON.....	EA	4
59	18	PAHZZ	5915-00-061-1346	20JX35	56219	FILTER, RADIO FREQUE.....	EA	2
59	19	PAHZZ	5940-00-557-1628	MS25036-56	96906	TERMINAL, LUG.....	EA	4
59	20	XDHZZ		MS35690-140	96906	NUT, PLAIN, HEXAGON.....	EA	1
59	21	PAHZZ	5310-00-933-8121	MS35338-139	96906	WASHER, LOCK.....	EA	6
59	22	PAHZZ	5310-00-527-3634	MS35335-61	96906	WASHER, LOCK.....	EA	1
59	23	XDHZZ		MS604-2XXXPIC	75382	STRIP, MARKER.....	EA	1
					153			

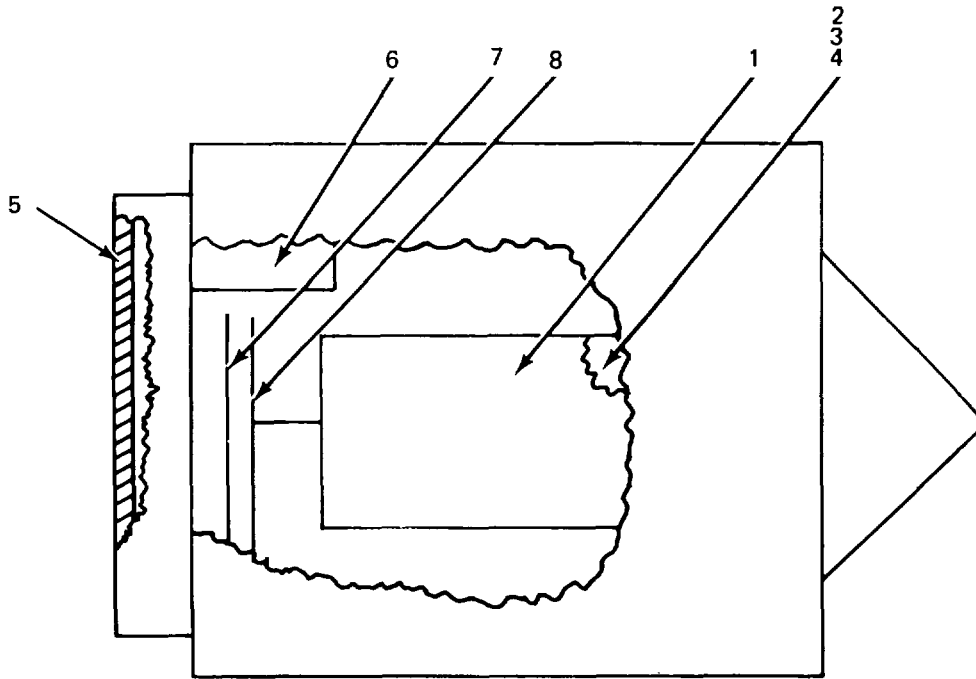

EL0QM069

Figure 60. Blower B1.

SECTION II

TM 11-7440-222-40P/NAVELEX 0967-LP-324-0480/TO 31W4-2G-84

(1) ILLUSTRATION		(2)	(3)	(4)	(5)	(6) DESCRIPTION	(7)	(8)
(a) FIG NO.	(b) ITEM NO.	SMR CODE	NATIONAL STOCK NUMBER	PART NUMBER	FSCM	USABLE ON CODE	U/M	QTY INC IN UNIT
						GROUP 09 BLOWER B1		
60	1	PAHZZ	6105-00-134-5596	5-1783	036522	MOTOR, ALTERNATING C.....	EA	1
60	2	PAHZZ	5305-00-054-6669	MS51957-44	96906	SCREW, MACHINE.....	EA	4
60	3	PAHZZ	5310-00-558-6207	AN960C8L	88044	WASHER, FLAT.....	EA	4
60	4	PAHZZ	5310-00-933-8119	MS35338-137	96906	WASHER, LOCK.....	EA	4
60	5	PAHZZ	4130-00-864-0650	5-1006-5	03522	FILTER ELEMENT, AIR.....	EA	1
60	6	PAHZZ	5910-00-823-1640	5-1309	03522	CAPACITOR, FIXED, PAP.....	EA	1
60	7	XDHZZ		5-1364	03522	IMPELLER, FAN, CENTRI.....	EA	1
60	8	PAHZZ	4140-00-988-3695	5-1365	03522	IMPELLER, FAN, CENTRI.....	EA	1
					155			

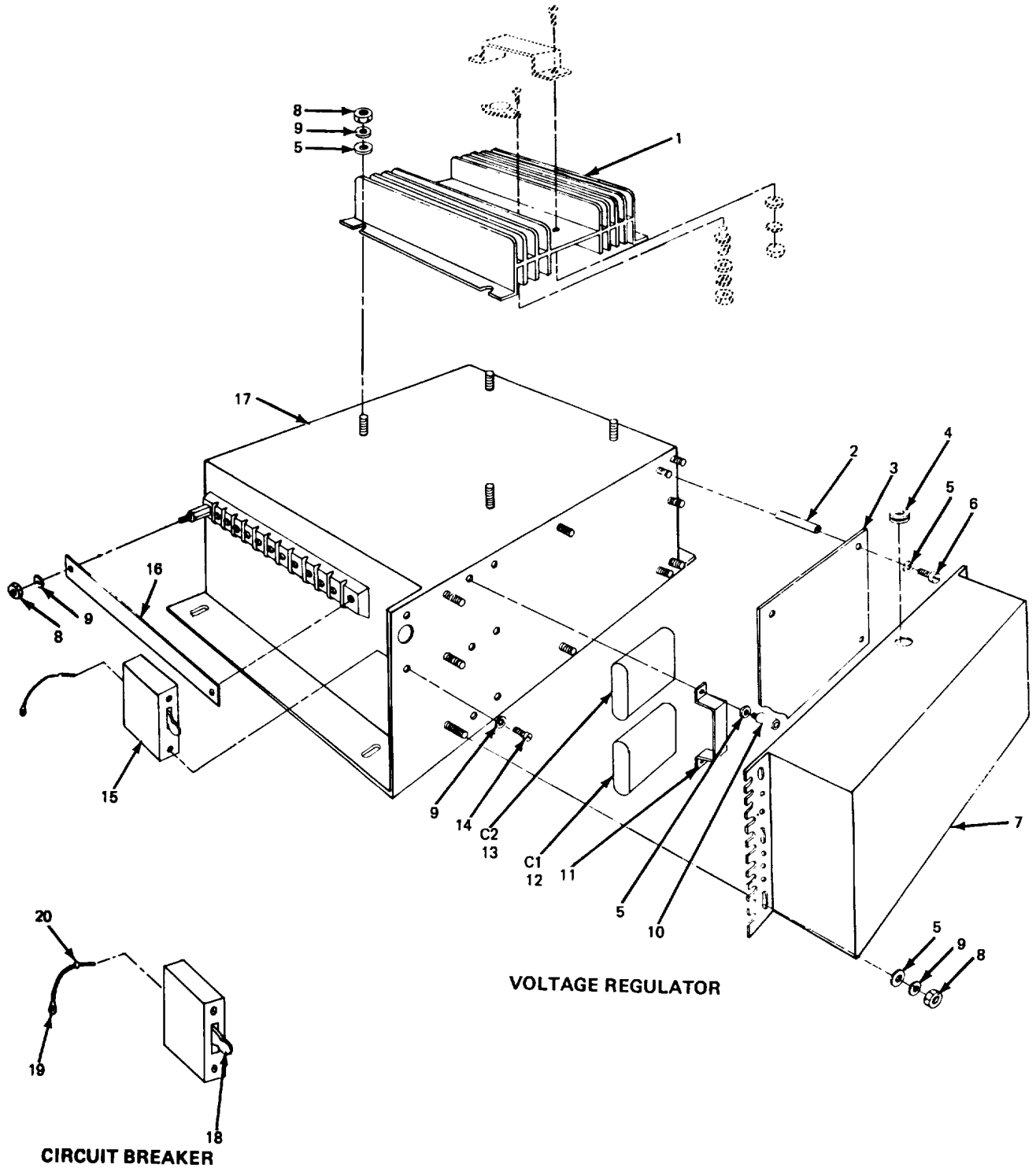

ELOQM070

Figure 61. Voltage Regulator Assembly VR1 and Circuit Breaker Assembly.

SECTION II

(1) ILLUSTRATION		(2)	(3)	(4)	(5)	(6) DESCRIPTION	(7)	(8)
(a) FIG NO.	(b) ITEM NO.	SMR CODE	NATIONAL STOCK NUMBER	PART NUMBER	FSCM	USABLE ON CODE	U/M	QTY INC IN UNIT
						GROUP 10 VOLTAGE REGULATOR ASSEMBLY VR1		
61	1	XDHHH		W-7712-26	08715	HEATSINK ASSEMBLY	EA	1
61	2	XDHZZ		386	75306	SPACER.....	EA	6
61	3	XDHHH		W-7712-27	08715	PRINTED CKT ASSY	EA	1
61	4	XDHZZ		91122	08280	GROMMET	EA	1
61	5	PAHZZ	5310-00-531-9514	AN960C6	88044	WASHER, FLAT	EA	11
61	6	PAHZZ	5305-00-637-7079	MS35223-26	96906	SCREW MACHINE.....	EA	4
61	7	XDHZZ		W-7712-9	08715	COVER, COMPONENT.....	EA	1
61	8	PAHZZ	5310-00-934-9761	MS35649-264	96906	NUT, PLAIN, HEXAGON.....	EA	4
61	9	PAHZZ	5310-00-929-6395	MS35338-136	96906	WASHER, LOCK	EA	4
61	10	XDHZZ		W-7712-24	08715	FASTNER, SPECIAL.....	EA	6
61	11	XDHZZ		W-7712-10	08715	STRAP, CAPACITOR.....	EA	4
61	12	PAHZZ	5910-00-159-7336	W-7712-C1-A	08715	CAPACITOR, FIXED, PAP SELECT	EA	1
61	12	PAHZZ	5910-00-159-7361	W-7712-C1-B	08715	CAPACITOR, FIXED, PAP SELECT	EA	1
61	12	PAHZZ	5910-00-159-7337	W-7712-C1-C	08715	CAPACITOR, FIXED, PAP SELECT	EA	1
61	13	PAHZZ	5910-00-165-2520	W-7712-C2-A	08715	CAPACITOR, FIXED, PAP SELECT	EA	1
61	13	PAHZZ	5910-00-159-7338	W-7712-C2-B	08715	CAPACITOR, FIXED, PAP SELECT.....	EA	1
61	13	PAHZZ	5910-00-164-9695	W-7712-C2-C	08715	CAPACITOR, FIXED, PAP SELECT	EA	1
61	14	PAHZZ	5305-00-638-3435	MS35223-25	96906	SCREW MACHINE.....	EA	2
61	15	XDHHH		W-7712-30	08715	CIRCUIT BRKR ASSY.....	EA	1
61	16	XDHZZ		W-7712-16	08715	COVER, TERMINAL BD.....	EA	1
61	17	XDHZZ		W-7712-28	08715	MAGNETIC ASSEMBLY.....	EA	1
						GROUP 1001 CIRCUIT BREAKER ASSEMBLY		
61	18	XDHZZ		JA-1-WGM-JHP	74193	CIRCUIT BREAKER.....	EA	1
61	19	XDHZZ		A-534-06	98410	TERMINAL, LUG	EA	4
61	20	XDHZZ	5940-00-478-0024	AA-8140	98410	TERMINAL, QUICK DISC.....	EA	4

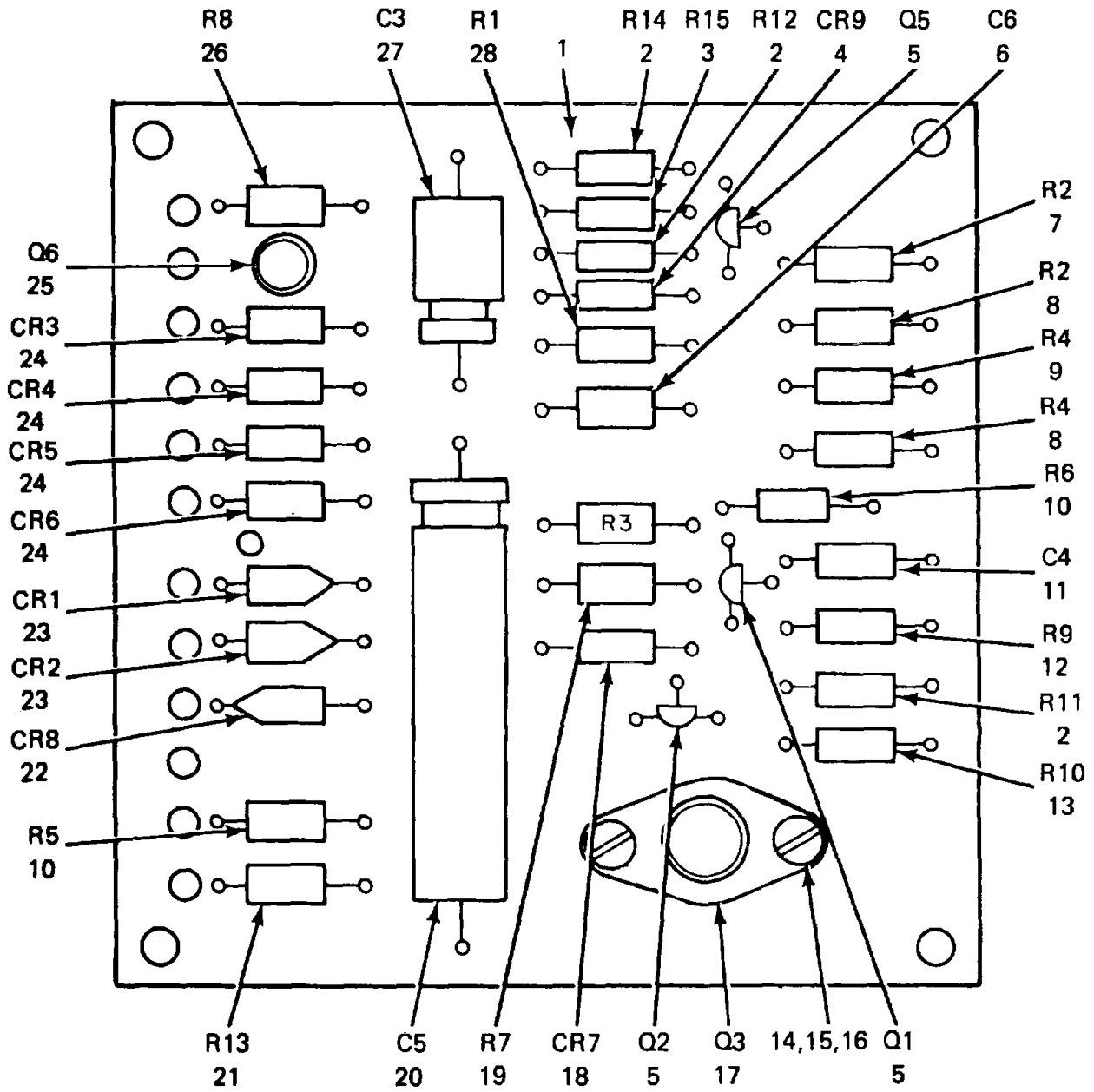

EL0QM071

Figure 62. Printed Circuit Board Assembly (W-7712-27)

(1) ILLUSTRATION		(2)	(3)	(4)	(5)	(6) DESCRIPTION	(7)	(8)
(a) FIG NO.	(b) ITEM NO.	SMR CODE	NATIONAL STOCK NUMBER	PART NUMBER	FSCM	USABLE ON CODE	U/M	QTY INC IN UNIT
						GROUP 1002 PRINTED CIRCUIT BOARD ASSEMBLY (W-7712-27)		
62	1	XDHZZ		W-7712-13	08715	PRINTED CKT CARD.....	EA	1
62	2	PAHZZ	5905-00-195-6451	RC20GF472K	81349	RESISTOR, FIXED, COMP.....	EA	3
62	3	PAHZZ	5905-00-110-0310	RC20GF392K	81349	RESISTOR, FXD, CARBON.....	EA	1
62	4	PAHZZ	5961-00-852-7549	1N754A	81349	SEMICONDUCTOR, DIODE.....	EA	1
62	5	PAHZZ	5961-00-931-0372	2N3906	80131	TRANSISTOR.....	EA	3
62	6	PAHZZ	5910-00-807-7253	150D226X001582	56289	CAPACITOR, FIXED, ELE.....	EA	1
62	7	XDHZZ		RG20-6200-G	16299	RESISTOR, MET GLZ SELECT.....	EA	1
62	8	PAHZZ	5905-00-229-2620	RC20GF223K	81349	RESISTOR, FIXED, COMP SELECT.....	EA	2
62	8	PAHZZ	5905-00-195-6758	RC20GF273K	81349	RESISTOR, FIXED, COMP SELECT.....	EA	2
62	8	PAHZZ	5905-00-249-4248	RC20GF333K	81349	RESISTOR, FIXED, COMP SELECT.....	EA	2
62	8	PAHZZ	5905-00-190-8882	RC20GF393K	81349	RESISTOR, FIXED, COMP SELECT.....	EA	2
62	8	PAHZZ	5905-00-295-3410	RC20GF473K	81349	RESISTOR, FIXED, COMP SELECT.....	EA	2
62	8	PAHZZ	5905-00-192-3988	RC20GF563K	81349	RESISTOR, FIXED, COMP SELECT.....	EA	2
62	8	PAHZZ	5905-00-114-5489	RC20GF823K	81349	RESISTOR, FIXED, COMP SELECT.....	EA	2
62	8	PAHZZ	5905-00-192-3987	RC20GF104K	81349	RESISTOR, FIXED, COMP SELECT.....	EA	2
62	8	PAHZZ	5905-00-254-7087	RC20GF683K	81349	RESISTOR, FIXED, COMP SELECT.....	EA	2
62	8	PAHZZ	5905-00-104-8335	RC20GF124K	81349	RESISTOR, FIXED, COMP SELECT.....	EA	2
62	8	PAHZZ	5905-00-192-9260	RC20GF154K	81349	RESISTOR, FIXED, COMP SELECT.....	EA	2
62	8	PAHZZ	5905-00-192-0662	RC20GF184K	81349	RESISTOR, FIXED, COMP SELECT.....	EA	2
62	8	PAHZZ	5905-00-114-5393	RC20GF224K	81349	RESISTOR, FIXED, COMP SELECT.....	EA	2
62	9	XDHZZ		RG20-2000-G	16299	RESISTOR, MET GLZ SELECT.....	EA	1
62	10	PAHZZ	5905-00-186-3008	RC20GF102K	81349	RESISTOR, FIXED, COMP.....	EA	2
62	11	PAHZZ	5910-00-007-2004	150D475X0035B2	56289	CAPACITOR, FIXED, ELE.....	EA	1
62	12	PAHZZ	5905-00-195-6817	RC20GF102K	81349	RESISTOR, FIXED, COMP.....	EA	1
62	13	PAHZZ	5905-00-195-6502	RC20GF332K	81349	RESISTOR, FIXED, COMP.....	EA	1
62	14	PAHZZ	5305-00-207-0763	MS35223-28	96906	SCREW, MACHINE.....	EA	2
62	15	PAHZZ	5310-00-616-3555	MS35333-71	96906	WASHER, LOCK.....	EA	2
62	16	PAHZZ	5310-00-934-9761	MS35649-264	96906	NUT, PLAIN, HEXAGON.....	EA	2
62	17	PAHZZ	5961-00-850-8921	2N3738	81349	TRANSISTOR.....	EA	1
62	18	XDHZZ		1N752A	81349	SEMICONDUCTOR, DIODE.....	EA	1
62	19	PAHZZ	5905-00-111-8357	RC20GF681K	81349	RESISTOR, FIXED, COMP.....	EA	1
62	20	XDHZZ		110D107X0050R0	56289	CAPACITOR.....	EA	1
62	21	PAHZZ	5905-00-060-3731	RW69V1R0	81349	RESISTOR, FIXED, WIRE.....	EA	1
62	22	XDHZZ		1.5R75	13327	SEMICONDUCTOR DIODE.....	EA	1
62	23	PAHZZ	5961-00-078-1650	2A200	13327	SEMICONDUCTOR DEVIC.....	EA	2
62	24	PAHZZ	5961-00-481-7539	TW-20	13327	SEMICONDUCTOR DEVIC.....	EA	4
62	25	PAHZZ	5961-00-752-6081	2N657	81349	TRANSISTOR.....	EA	1
62	26	XDHZZ		RG20-910-G	11502	RESISTOR, MET GLZ.....	EA	1

SECTION II

TM 11-7440-222-40P/NAVELEX 0967-LP-324-0480/TO 31W4-2G-84

(1) ILLUSTRATION		(2)	(3)	(4)	(5)	(6)	(7)	(8)
(a) FIG NO.	(b) ITEM NO.	SMR CODE	NATIONAL STOCK NUMBER	PART NUMBER	FSCM	DESCRIPTION USABLE ON CODE	U/M	QTY INC IN UNIT
62	27	PAHZZ	5910-01-016-0116	M39006-09-8717	81349	CAPACITOR.....	EA	1
62	28	XDHZZ		RC20S222G	75042	RESISTOR, MET, GLZ.....	EA	1

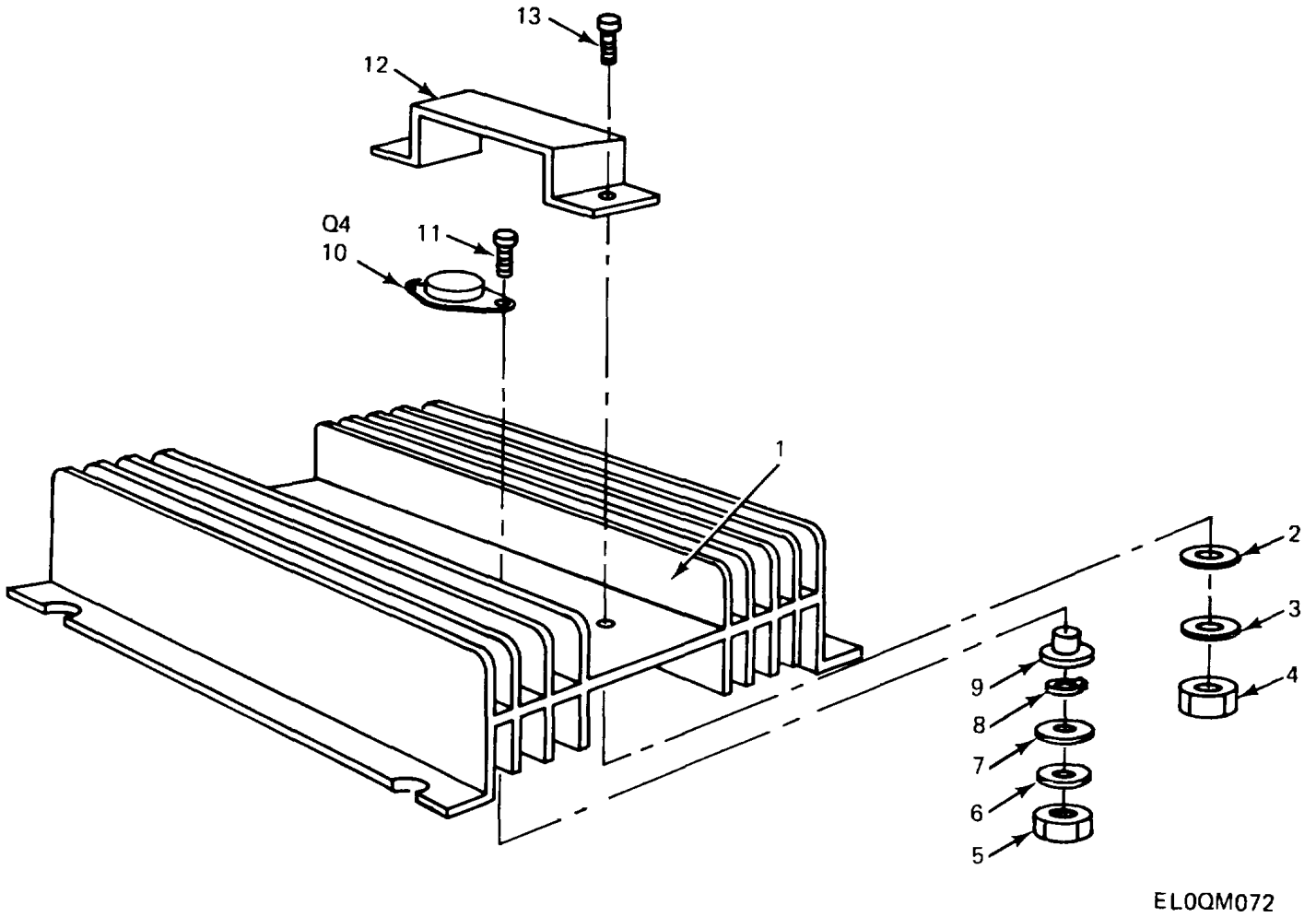
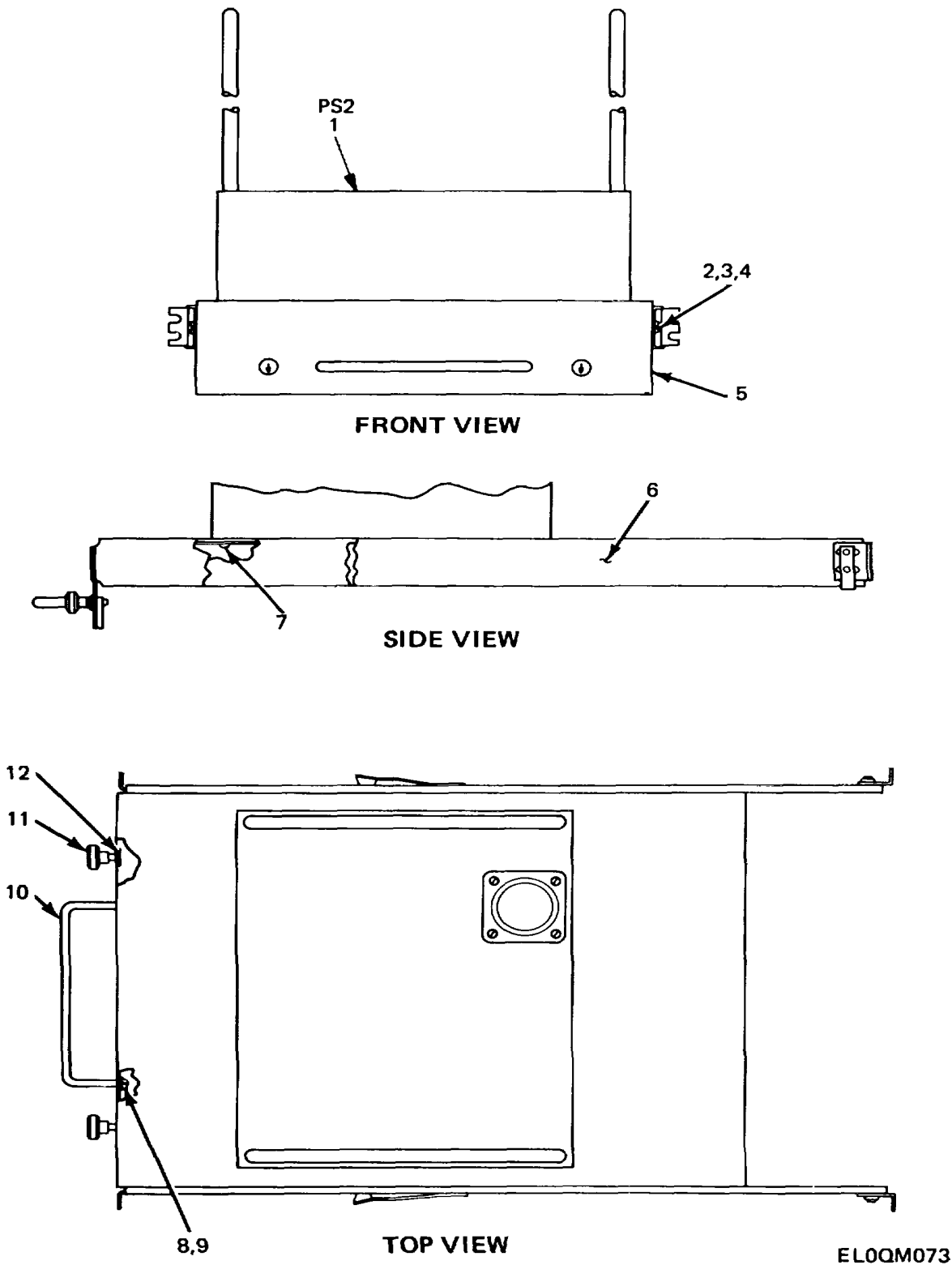

Figure 63. Heat Sink Assembly (W-7712-26).

SECTION II

(1) ILLUSTRATION		(2)	(3)	(4)	(5)	(6) DESCRIPTION	(7)	(8)
(a) FIG NO.	(b) ITEM NO.	SMR CODE	NATIONAL STOCK NUMBER	PART NUMBER	FSCM	USABLE ON CODE	U/M	QTY INC IN UNIT
						GROUP 1003 HEAT SINK ASSEMBLY (W-7712-26)		
63	1	XDHZZ		W-7712-7	08715	HEATSINK.....	EA	1
63	2	PAHZZ	5310-00-782-1349	AN960C4	88044	WASHER, FLAT	EA	1
63	3	PAHZZ	5310-00-933-8118	MS35338-135	96906	WASHER, LOCK	EA	1
63	4	PAHZZ	5310-00-271-4642	MS35649-44	96906	WASHER.....	EA	1
63	5	PAHZZ	5310-00-934-9761	MS35649-264	96906	NUT, PLAIN, HEXAGON	EA	1
63	6	PAHZZ	5310-00-929-6395	MS35338-136	96906	WASHER, LOCK	EA	1
63	7	PAHZZ	5310-00-531-9514	AN960C6	88044	WASHER, FLAT	EA	1
63	8	XDHZZ		17-31	81349	TERMINAL, LUG	EA	1
63	9	XDHZZ		386	75306	SPACER.....	EA	1
63	10	PAHZZ	5961-00-161-3454	SDT1055	13327	TRANSISTOR.....	EA	1
63	11	PAHZZ	5305-00-889-3001	MS35223-31	96906	SCREW, MACHINE.....	EA	2
63	12	XDHZZ		W7712-15	08715	COVER.....	EA	1
63	13	PAHZZ	5305-00-889-2999	MS35223-17	96906	SCREW, MACHINE.....	EA	2



EL0QM073

Figure 64. Power Supply Assembly PS2.

SECTION II

(1) ILLUSTRATION		(2)	(3)	(4)	(5)	(6)	(7)	(8)
(a) FIG NO.	(b) ITEM NO.	SMR CODE	NATIONAL STOCK NUMBER	PART NUMBER	FSCM	DESCRIPTION USABLE ON CODE	U/M	QTY INC IN UNIT
						GROUP 11 POWER SUPPLY ASSEMBLY PS2		
64	1	XDHXX		56056-G1	06809	POWER SUPPLY.....	EA	1
64	2	PAHZZ	5305-00-059-3659	MS51958-63	96906	SCREW, MACHINE.....	EA	4
64	3	PAHZZ	5310-00-933-8120	MS35338-138	96906	WASHER, LOCK.....	EA	6
64	4	PAHZZ	5310-00-934-9765	MS35650-304	96906	NUT, PLAIN, HEXAGON.....	EA	4
64	5	XDHZZ		A64539-001	58189	CHASSIS, PWR, SPLY.....	EA	1
64	6	XDHZZ		C300S24	06666	SLIDE, DRAWER, EXTENS.....	EA	2
64	7	PAHZZ	5305-00-071-1322	MS51960-65	96906	SCREW, MACHINE.....	EA	4
64	8	PAHZZ	5310-00-167-0812	AN960C10L	88044	WASHER, FLAT.....	EA	2
64	9	PAHZZ	5305-00-059-3660	MS51958-64	96906	SCREW, MACHINE.....	EA	2
64	10	PAHZZ	5340-00-984-8854	MS39087-1	96906	HANDLE, BOW.....	EA	1
64	11	PAHZZ	5340-00-684-9956	49-1-1-0	94222	LATCH SET, RIM.....	EA	2
64	12	XDHZZ	5310-00-531-9515	AN960C416	88044	WASHER, FLAT.....	EA	2

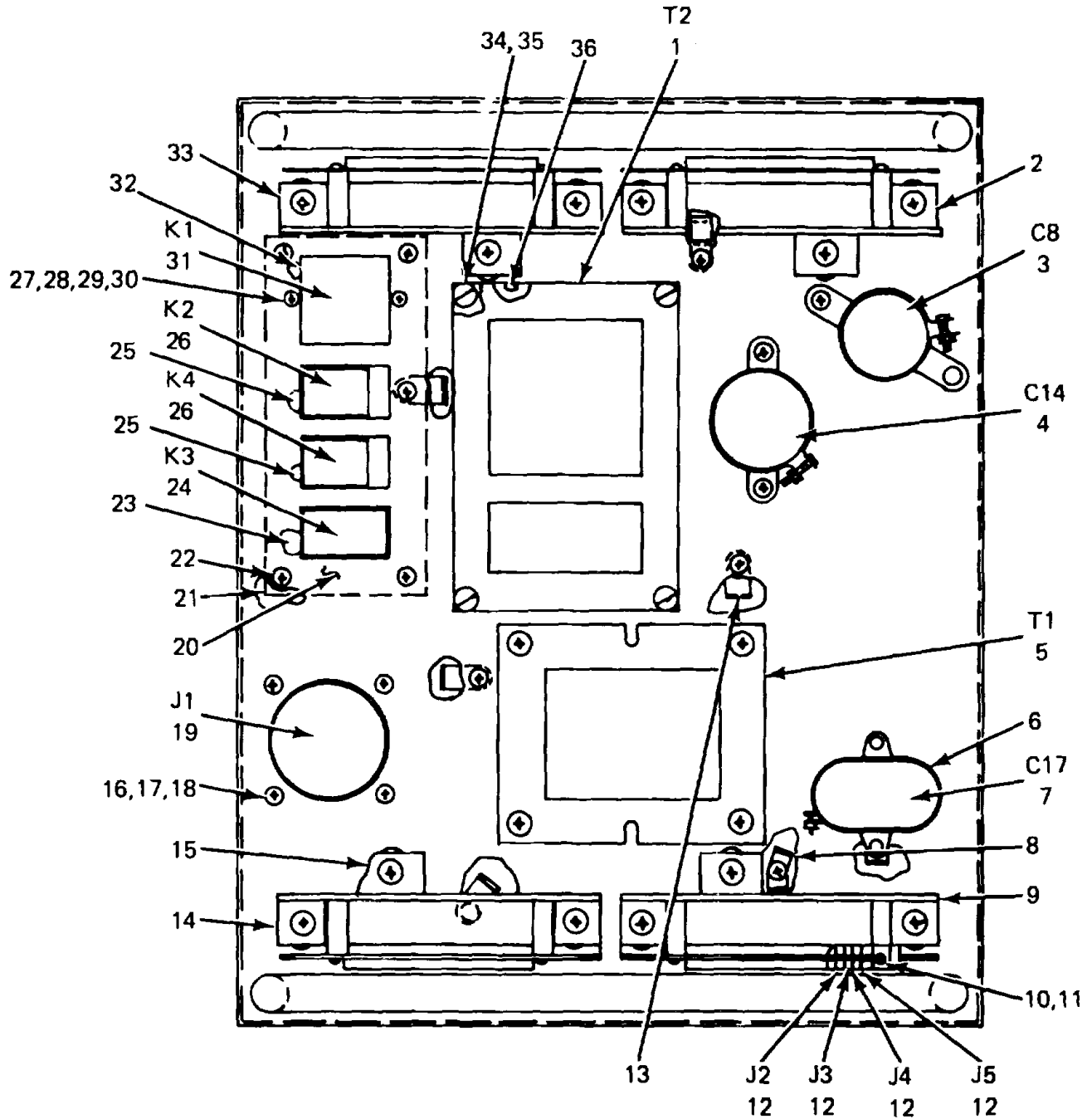

TOP VIEW

NOTE: PREFIX ALL REFERENCE DESIGNATIONS WITH PS2

ELOQM074

Figure 65. Power Supply PS2 (Sheet 1 of 3).

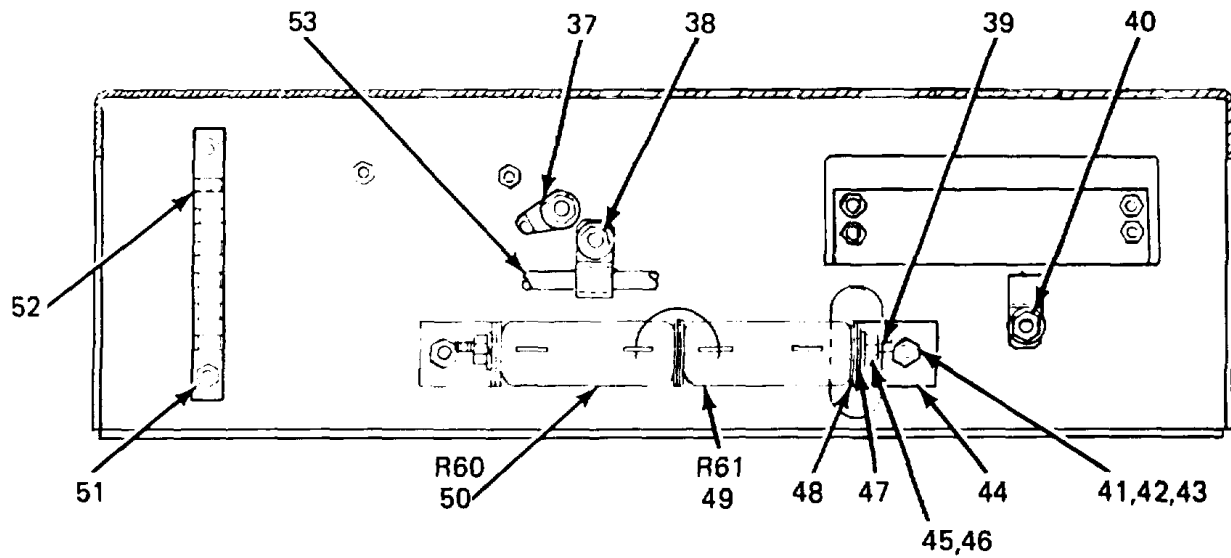

REAR VIEW, FRONT

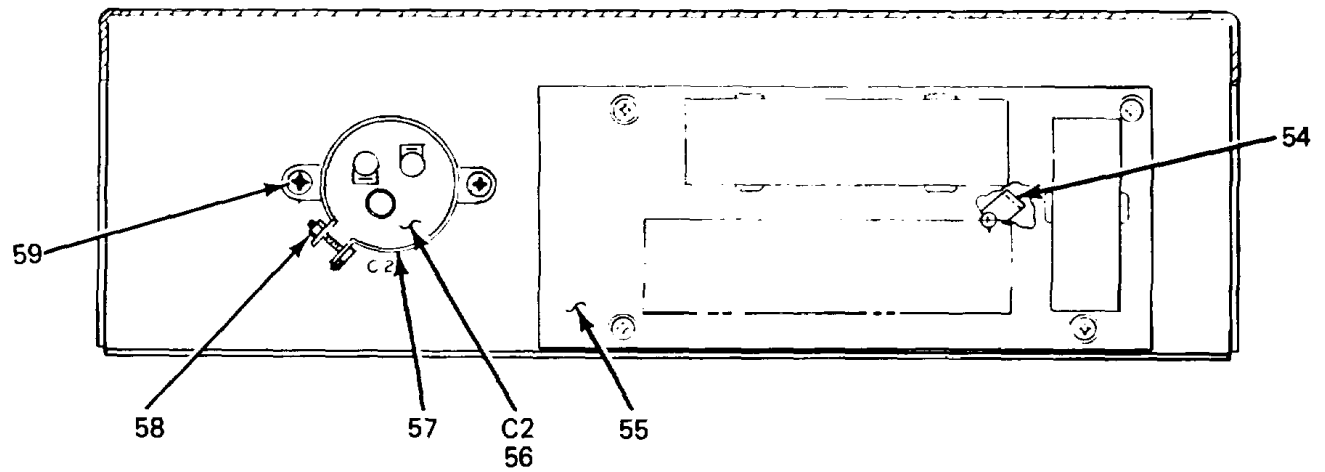

FRONT VIEW, REAR

NOTE: PREFIX ALL REFERENCE DESIGNATIONS WITH PS2

EL0QM075

Figure 65. Power Supply PS2 (Sheet 2 of 3).

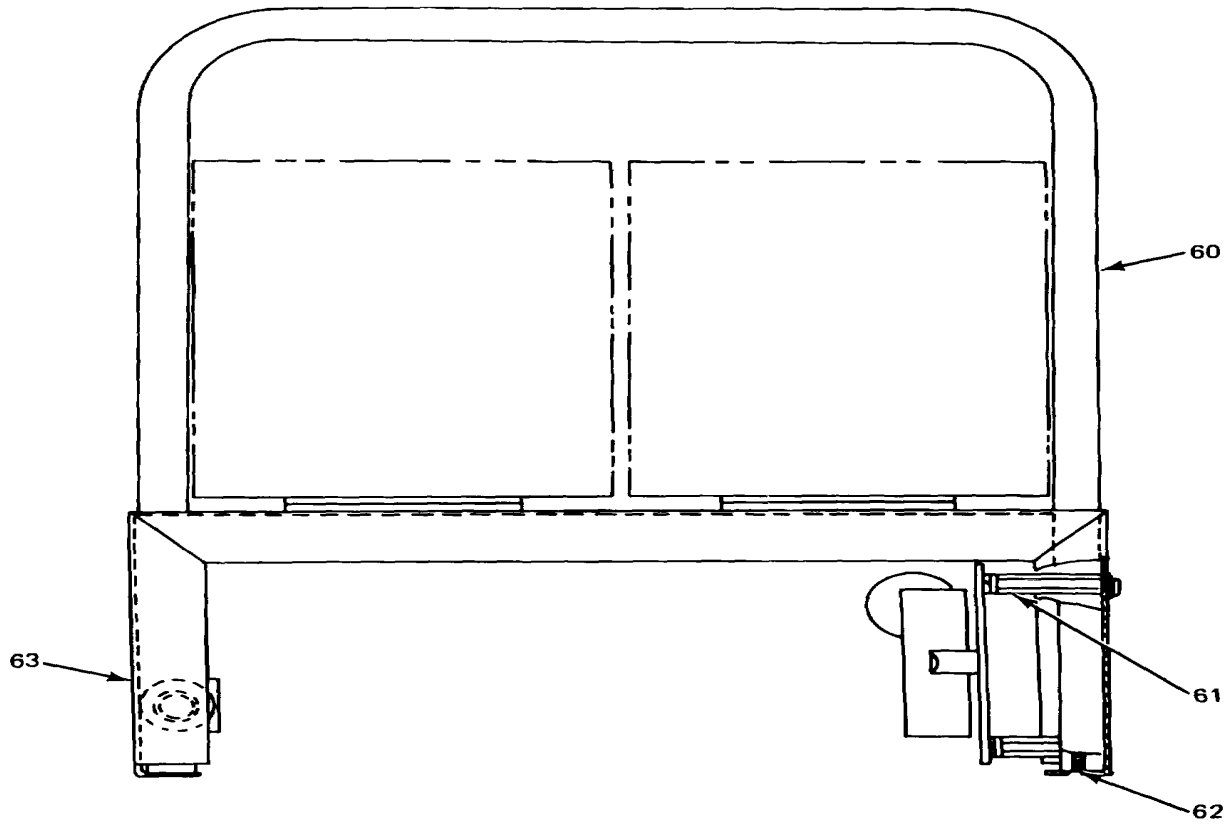

SIDE VIEW

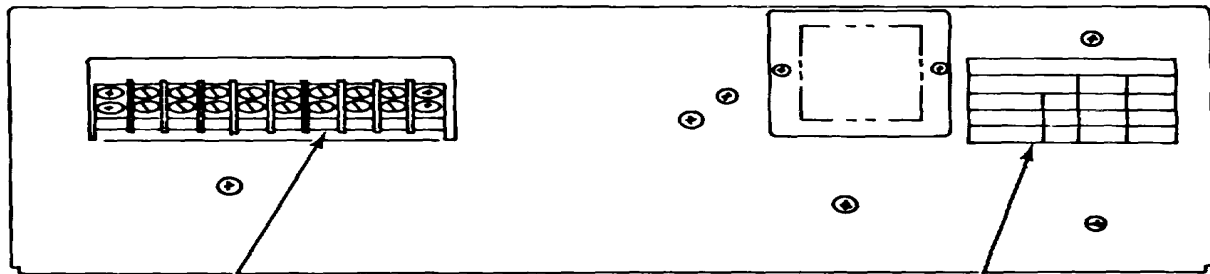

REAR VIEW

NOTE: PREFIX ALL REFERENCE DESIGNATIONS WITH PS2

ELOQM076

Figure 65. Power Supply PS2 (Sheet 3 of 3).

(1) ILLUSTRATION		(2)	(3)	(4)	(5)	(6) DESCRIPTION	(7)	(8)
(a) FIG NO.	(b) ITEM NO.	SMR CODE	NATIONAL STOCK NUMBER	PART NUMBER	FSCM	USABLE ON CODE	U/M	QTY INC IN UNIT
GROUP 1101 POWER SUPPLY PS2								
65	1	XDHZZ		B126-2870	55938	TRANSFORMER.....	EA	1
65	2	PAHDL	5999-00-096-9985	12-890143-001	12436	CIRCUIT CARD ASSEMB.....	EA	1
65	3	XDHZZ		QE-17	04222	CAPACITOR, ELCTLT	EA	1
65	4	PAHZZ	5910-00-929-5008	32D143G015AF6C	56289	CAPACITOR, ELCTLT	EA	1
65	5	XDHZZ		B126-2871	55938	TRANSFORMER.....	EA	1
65	6	XDHZZ		32115-1	14655	CLAMP, CAPACITOR	EA	1
65	7	XDHZZ		35-H-11P1-200P112	56289	CAPACITOR.....	EA	1
65	8	XDHZZ		SMC546211-3	80063	CLAMP, LOOP	EA	3
65	9	PAHDL	5999-00-926-3227	12-890142-002	12436	CIRCUIT CARD ASSEMB.....	EA	1
65	10	PAHZZ	5305-00-054-5625	MS51957-18	96906	SCREW, MACHINE.....	EA	1
65	11	XDHZZ	5310-00-811-6419	MS21042-04	96906	NUT, SELF-LOCKING, EX.....	EA	8
65	12	XDHZZ		250-15-30-220	71785	CONNECTOR, RECEPTACL.....	EA	4
65	13	XDHZZ		SMC546211-4	80063	CLAMP, LOOP	EA	2
65	14	PAHDL	5999-00-926-3228	12-890141-002	12436	CIRCUIT CARD ASSEMB.....	EA	1
65	15	PAHZZ	5340-00-862-7670	G1032	00613	SHIELD, EXPANSION.....	EA	12
65	16	XDHZZ	5310-00-880-5976	MS15795-806	96906	WASHER, FLAT	EA	4
65	17	PAHZZ	5305-00-054-6655	MS51957-31	96906	SCREW, MACHINE.....	EA	4
65	18	PAHZZ	5310-00-934-9761	M35649-264	96906	NUT, PLAIN, HEXAGON.....	EA	4
65	19	PAHZZ	5935-00-837-1238	MS3102R28-12PW	96906	CONNECTOR, RECEPTACL.....	EA	1
65	20	XDHHH		00-001659-001	06809	PLATE, MTG, RELAY.....	EA	1
65	21	XDHZZ		01-003082-001	06809	PLATE, MTG, RELAY	EA	1
65	22	PAHZZ	5305-00-054-6654	MS51957-30	96906	SCREW, MACHINE.....	EA	5
65	23	PAHZZ	5935-00-940-3119	30055-8	02288	SOCKET.....	EA	1
65	24	PAHZZ	5945-00-921-0378	T163-4C12VDC	02288	RELAY, ARMATURE.....	EA	1
65	25	PAHZZ	5935-00-830-6349	30055-1	02288	SOCKET, PLUG-IN ELEC.....	EA	2
65	26	PAHZZ	5945-00-921-1162	T163-2C24VDC	02288	RELAY, ARMATURE.....	EA	2
65	27	PAHZZ	5310-00-933-8118	MS35338-135	96906	WASHER, LOCK	EA	2
65	28	XDHZZ	5310-00-782-1349	MS15795-804	96906	WASHER, FLAT	EA	15
65	29	PAHZZ	5305-00-054-5649	MS51957-15	96906	SCREW, MACHINE.....	EA	2
65	30	XDHZZ	5310-00-934-9748	MS35649-244	96906	NUT, PLAIN, HEXAGON.....	EA	9
65	31	PAHZZ	5945-00-929-7871	W88CPX5	94696	RELAY, ELECTRICAL.....	EA	1
65	32	XDHZZ	5935-00-321-5113	77-M1P-8-T	02660	SOCKET, PUG-IN ELEC.....	EA	1
65	33	PAHDL	7040-00-877-7879	12-890140-002	12436	CIRCUIT CARD ASSEMB.....	EA	1
65	34	PAHZZ	5940-00-815-2093	MS77068-3	96906	TERMINAL, LUG	EA	1
65	35	PAHZZ	5310-00-225-5328	MS15795-841	96906	WASHER, FLAT	EA	8
65	36	PAHZZ	5940-00-813-0698	MS25036-101	96906	TERMINAL, LUG	EA	4
65	37	PAHZZ	5940-00-827-2653	MS77068-2	96906	TERMINAL, LUG	EA	1
65	38	XDHZZ	5305-00-763-6963	MS51959-28	96906	SCREW, MACHINE.....	EA	1

SECTION II

TM 11-7440-222-40P/NAVELEX 0967-LP-324-0480/TO 31W4-2G-84

(1) ILLUSTRATION		(2)	(3)	(4)	(5)	(6)	(7)	(8)
(a) FIG NO.	(b) ITEM NO.	SMR CODE	NATIONAL STOCK NUMBER	PART NUMBER	FSCM	DESCRIPTION USABLE ON CODE	U/M	QTY INC IN UNIT
65	39	XDHZZ		01-003085-002	06809	STUD, THREADED	EA	1
65	40	XDHZZ	5305-00-727-8832	MS51959-29	96906	SCREW, MACHINE	EA	1
65	41	PAHZZ	5310-00-934-9761	MS35649-264	96906	NUT, PLAIN, HEXAGON	EA	2
65	42	PAHZZ	5310-00-929-6395	MS35338-136	96906	WASHER, LOCK	EA	2
65	43	XDHZZ	5310-00-880-5976	MS15795-806	96906	WASHER, FLAT	EA	63
65	44	XDHZZ		01-003084-001	06809	BRACKET MOUNTING	EA	2
65	45	PAHZZ	5310-00-934-9759	MS35649-284	96906	NUT, PLAIN, HEXAGON	EA	2
65	46	PAHZZ	5310-00-933-8119	MS35338-137	96906	WASHER, LOCK	EA	2
65	47	XDHZZ		MS75009-5	96906	WASHER, SHOULDERED A	EA	4
65	48	XDHZZ	5970-00-881-3556	MS75009-3	96906	INSULATOR, WASHER	EA	4
65	49	PAHZZ	5905-00-804-3932	25F10	63743	RESISTOR, FIXED, WIRE	EA	1
65	50	PAHZZ	5905-00-279-2115	25F200	63743	RESISTOR, FIXED, WIRE	EA	1
65	51	PAHZZ	5305-00-763-7827	MS51959-18	96906	SCREW, MACHINE	EA	2
65	52	PAHZZ	5940-00-204-9414	6-170	71785	TERMINAL BOARD	EA	1
65	53	XDHHH		03-001477-001	06809	WIRING HARNESS	EA	1
65	54	XDHZZ		SMC546211-7	80063	CLAMP, LOOP	EA	6
65	55	PAHDL	5999-00-019-3098	00-001660-002	12436	CIRCUIT CARD ASSEMB	EA	1
65	56	PAHZZ	5910-00-102-9277	32D322G015AA6C	56589	CAPACITOR, ELCTLT	EA	1
65	57	XDHZZ		97A001X	95682	CLAMP, CAPACITOR	EA	3
65	58	PAHZZ	5310-00-807-1465	MS21042-06	96906	NUT, SELF-LOCKING, EX	EA	4
65	59	PAHZZ	5305-00-054-6652	MS51957-28	96906	SCREW, MACHINE	EA	2
65	60	XDHZZ		01-003080-001	06809	HANDLE	EA	2
65	61	XDHZZ		8223-A-0632	06540	SPACER, SLEEVE	EA	4
65	62	PAHZZ	5305-00-765-4257	MS51959-43	96906	SCREW, MACHINE	EA	4
65	63	XDHZZ		01-00389-001	06809	CHASSIS	EA	1
65	64	XDHZZ		01-003078-001	06809	PLATE, IDENT	EA	1
65	65	XDHZZ		800-14-KT26	75382	TERMINAL BLOCK	EA	1

170/(171 blank)

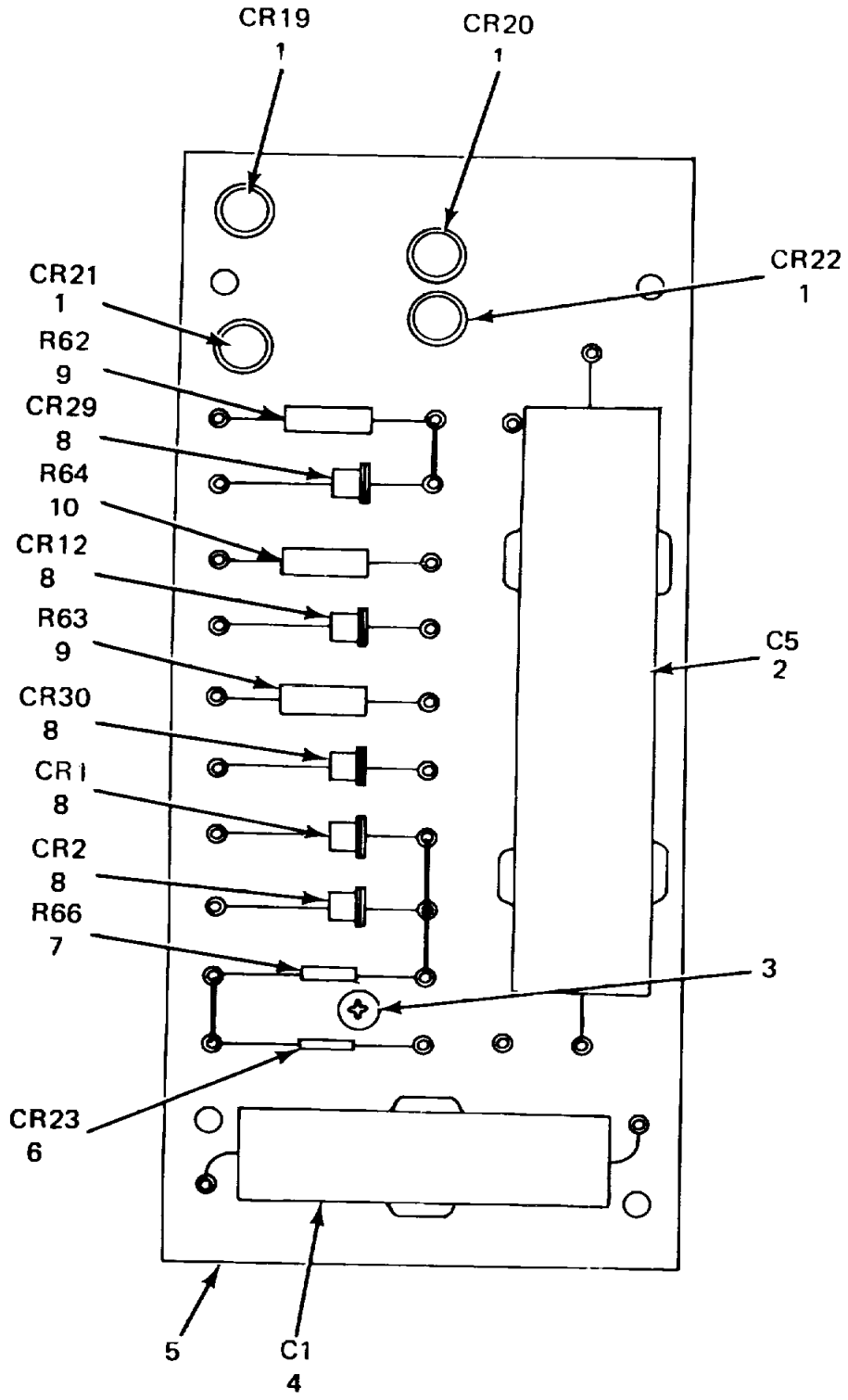

EL0QM077

Figure 66. Circuit Card Assembly (00-001660-002)

SECTION II

(1) ILLUSTRATION		(2)	(3)	(4)	(5)	(6)	(7)	(8)
(a) FIG NO.	(b) ITEM NO.	SMR CODE	NATIONAL STOCK NUMBER	PART NUMBER	FSCM	DESCRIPTION USABLE ON CODE	U/M	QTY INC IN UNIT
						GROUP 110101 CIRCUIT CARD ASSEMBLY (00-001660-002)		
66	1	XDDZZ	5961-00-827-4990	1N4997	04713	SEMICONDUCTOR DEVIC.....	EA	4
66	2	XDDZZ		34D258G015HP4	56289	CAPACITOR, FIXED, ELE	EA	1
66	3	PADZZ	5305-00-054-6656	MS51957-32	96906	SCREW, MACHINE.....	EA	1
66	4	PADZZ	5910-00-931-9890	34D108G15GL4	56289	CAPACITOR, ELCTLT	EA	1
66	5	XDDZZ		01-003081-003	06809	COMPONENT BOARD.....	EA	1
66	6	PADZZ	5961-00-468-3651	1N751	81349	SEMICONDUCTOR, SPECI.....	EA	1
66	7	XDDZZ	5905-00-252-5428	RC20GF680K	81349	RESISTOR, FIXED, COMP	EA	1
66	8	PADZZ	5961-00-577-6214	1N536	96214	SEMICONDUCTOR DEVIC.....	EA	5
66	9	XDDZZ		RC32G331K	81349	RESISTOR, FXD, CMPSN	EA	2
66	10	XDDZZ	5905-00-104-8347	RC32GF101K	81349	RESISTOR, FIXED, COMP	EA	1

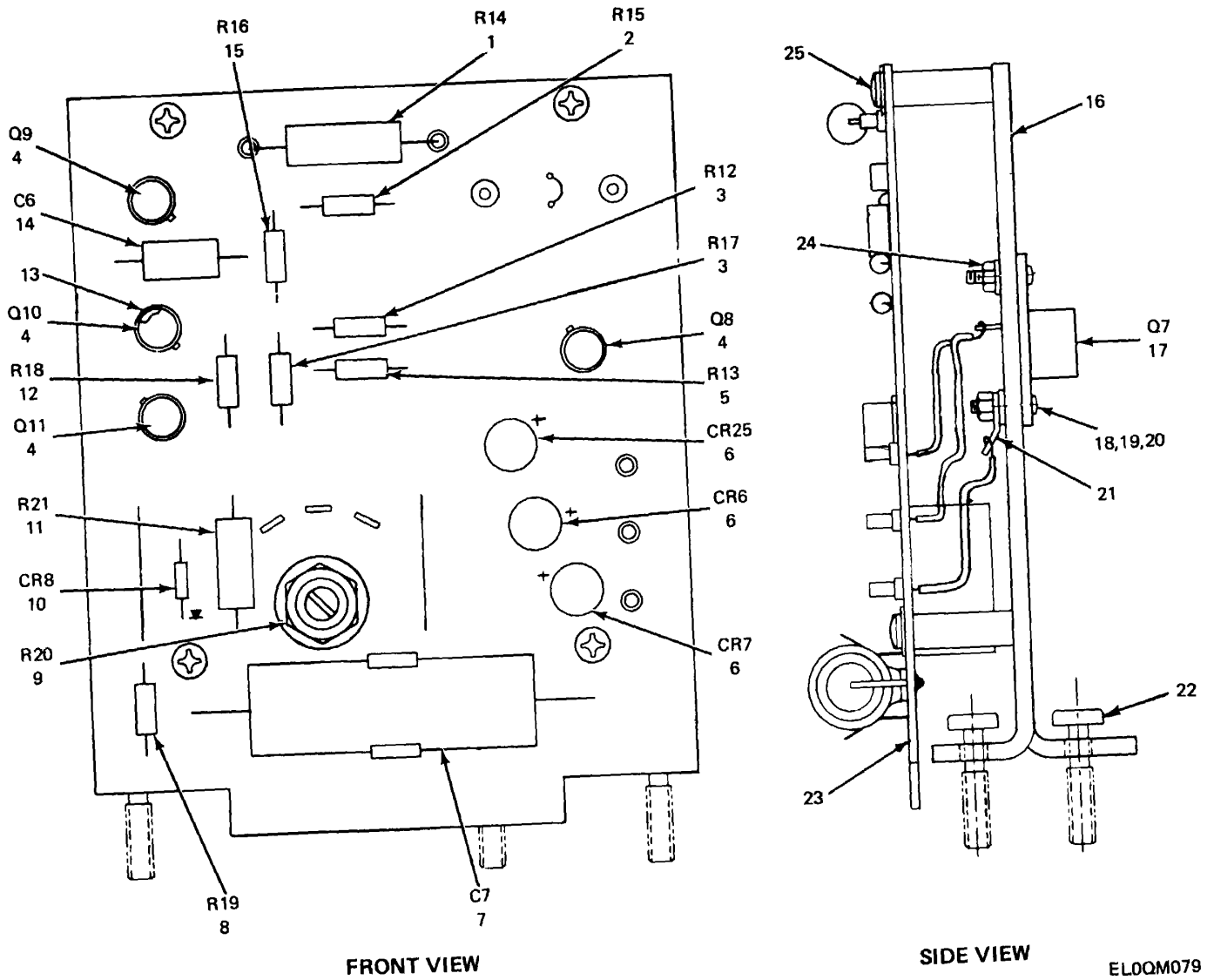
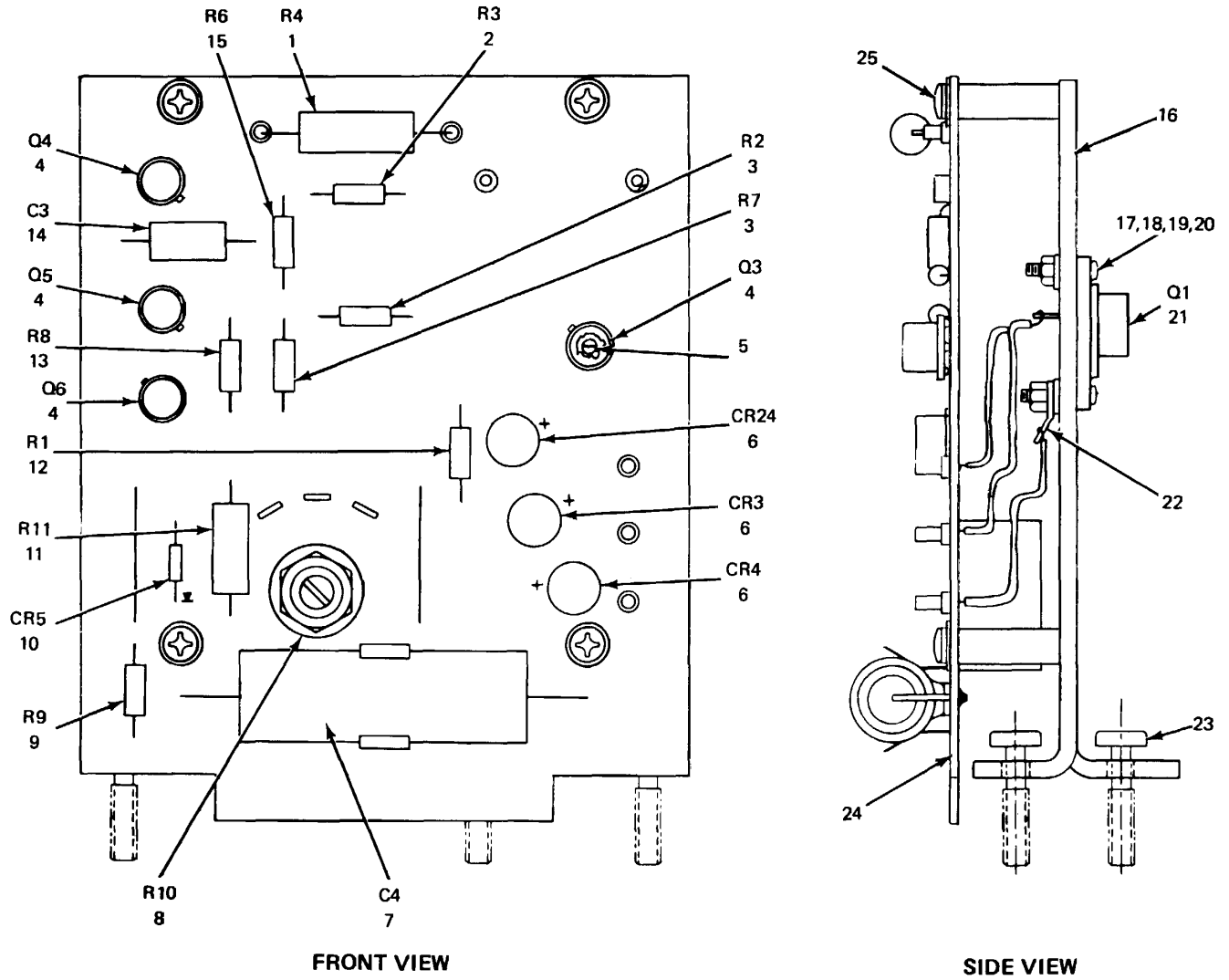

Figure 67. Circuit Card Assembly (12-890141-002).

SECTION II

TM 11-7440-222-40P/NAVELEX 0967-LP-324-0480/TO 31W4-2G-84

(1) ILLUSTRATION		(2)	(3)	(4)	(5)	(6) DESCRIPTION	(7)	(8)
(a) FIG NO.	(b) ITEM NO.	SMR CODE	NATIONAL STOCK NUMBER	PART NUMBER	FSCM	USABLE ON CODE	U/M	QTY INC IN UNIT
						GROUP 110102 CIRCUIT CARD ASSEMBLY (12-890141-002)		
67	1	XDDZZ		3X.68	63743	RESISTOR, FIXED.....	EA	1
67	2	XDDZZ	5905-00-279-1756	RC20GF151K	81349	RESISTOR, FIXED, COMP.....	EA	1
67	3	PADZZ	5905-00-279-2672	RC20GF182K	81349	RESISTOR, FIXED, COMP.....	EA	2
67	4	PADZZ	5961-00-931-0385	RT9343	49956	TRANSISTOR.....	EA	4
67	5	PADZZ	5305-00-054-6654	MS51957-30	96906	SCREW, MACHINE.....	EA	4
67	6	XDDZZ	5961-00-827-4990	1N4997	04713	SEMICONDUCTOR DEVIC.....	EA	3
67	7	XDDZZ		34D907G010FL4	56289	CAPACITOR, FIXED, ELE.....	EA	1
67	8	XDDZZ		29-479	12697	RESISTOR, VARIABLE.....	EA	1
67	9	PADZZ	5905-00-104-8334	RC20GF331K	81349	RESISTOR, FIXED, COMP.....	EA	1
67	10	PADZZ	5961-00-468-3651	1N751	81349	SEMICDNDUCTOR, SPECI.....	EA	1
67	11	XDDZZ		3X470	63743	RESISTOR, FIXED.....	EA	1
67	12	PADZZ	5905-00-279-1869	RC20GF121K	81349	RESISTOR, FIXED, COMP.....	EA	1
67	13	PADZZ	5905-00-195-6817	RC20GF102K	81349	RESISTOR, FIXED, COMP.....	EA	1
67	14	XDDZZ		V146XR0047200V	04222	CAPACITOR, FIXED.....	EA	1
67	15	PADZZ	5905-00-111-8357	RC20GF681K	81349	RESISTOR, FIXED, COMP.....	EA	1
67	16	XDDZZ		01-003087-011	06809	HEATSINK.....	EA	1
67	17	PADZZ	5310-00-934-9761	MS35649-264	96906	NUT, PLAIN, HEXAGON.....	EA	1
67	18	PADZZ	5305-00-054-6655	MS51957-31	96906	SCREW, MACHINE.....	EA	1
67	19	PADZZ	5310-00-929-6395	MS35338-136	96906	WASHER, LOCK.....	EA	1
67	20	XDDZZ	5310-00-880-5976	MS15795-806	96906	WASHER, FLAT.....	EA	1
67	21	PADZZ	5961-00-905-2926	40250	02735	TRANSISTOR.....	EA	1
67	22	PADZZ	5940-00-827-2653	MS77068-2	96906	TERMINAL, LUG.....	EA	1
67	23	XDDZZ		01-003086-001	06809	SCREW, MACHINE.....	EA	12
67	24	XDDZZ		12-870140-002	06809	PRINTED CKT BOARD.....	EA	1
67	25	PADZZ	5305-00-054-6652	MS51957-28	96906	SCREW, MACHINE.....	EA	1



ELOQM078

Figure 68. Circuit Card Assembly (12-890142-002).

(1) ILLUSTRATION		(2)	(3)	(4)	(5)	(6) DESCRIPTION	(7)	(8)
(a) FIG NO.	(b) ITEM NO.	SMR CODE	NATIONAL STOCK NUMBER	PART NUMBER	FSCM	USABLE ON CODE	U/M	QTY INC IN UNIT
						GROUP 110103 CIRCUIT CARD ASSEMBLY (12-890142-002)		
68	1	XDDZZ		3X1	63743	RESISTOR, FIXED.....	EA	1
68	2	XDDZZ	5905-00-279-1756	RC20GF151K	81349	RESISTOR, FIXED, COMP.....	EA	1
68	3	XDDZZ	5905-00-279-2672	RC20GF182K	81349	RESISTOR, FIXED, COMP.....	EA	2
68	4	PADZZ	5961-00-931-0385	RT9343	49956	TRANSISTOR.....	EA	4
68	5	PADZZ	5905-00-186-3008	RC20GF101K	81349	RESISTOR, FIXED, COMP.....	EA	1
68	6	XDDZZ	5961-00-827-4990	1N4997	04713	SEMICONDUCTOR DEVIC.....	EA	3
68	7	XDDZZ		34D907G010FL4	56289	CAPACITOR, FIXED, ELE.....	EA	1
68	8	PADZZ	5905-00-104-8334	RC20GF331K	81349	RESISTOR, FIXED, COMP.....	EA	1
68	9	XDDZZ		29-479	12697	RESISTOR, VARIABLE.....	EA	1
68	10	PADZZ	5961-00-468-3651	1N751	81349	SEMICONDUCTOR, SPECI.....	EA	1
68	11	XDDZZ		3X470	63743	RESISTOR, FIXED.....	EA	1
68	12	PADZZ	5905-00-195-6817	RC20GF102K	81349	RESISTOR, FIXED, COMP.....	EA	1
68	13	PADZZ	5999-00-946-0947	10079	07047	MOUNTING PAD, ELECTR.....	EA	4
68	14	XDDZZ		V146XR047200V	04222	CAPACITOR, FIXED.....	EA	1
68	15	PADZZ	5905-00-111-8357	RC20GF681K	81349	RESISTOR, FIXED, COMP.....	EA	1
68	16	XDDZZ		01-003087-004	06809	HEATSINK.....	EA	1
68	17	PADZZ	5961-00-905-2926	40250	02735	TRANSISTOR.....	EA	1
68	18	PADZZ	5305-00-054-6655	MS51957-31	96906	SCREW, MACHINE.....	EA	2
68	19	PADZZ	5310-00-929-6395	MS35338-136	96906	WASHER, LOCK.....	EA	2
68	20	XDDZZ	5310-00-880-5976	MS15795-806	96906	WASHER, FLAT.....	EA	2
68	21	PADZZ	5940-00-827-2653	MS77068-2	96906	TERMINAL, LUG.....	EA	4
68	22	XDDZZ		01-003086-001	06809	SCREW, MACHINE.....	EA	2
68	23	XDDZZ		12-870140-003	06809	PRINTED CIRCUIT BD.....	EA	1
68	24	PADZZ	5310-00-934-9761	MS35649-264	96906	NUT, PLAIN, HEXAGON.....	EA	2
68	25	PADZZ	5305-00-054-6652	MS51957-28	96906	SCREW, MACHINE.....	EA	4

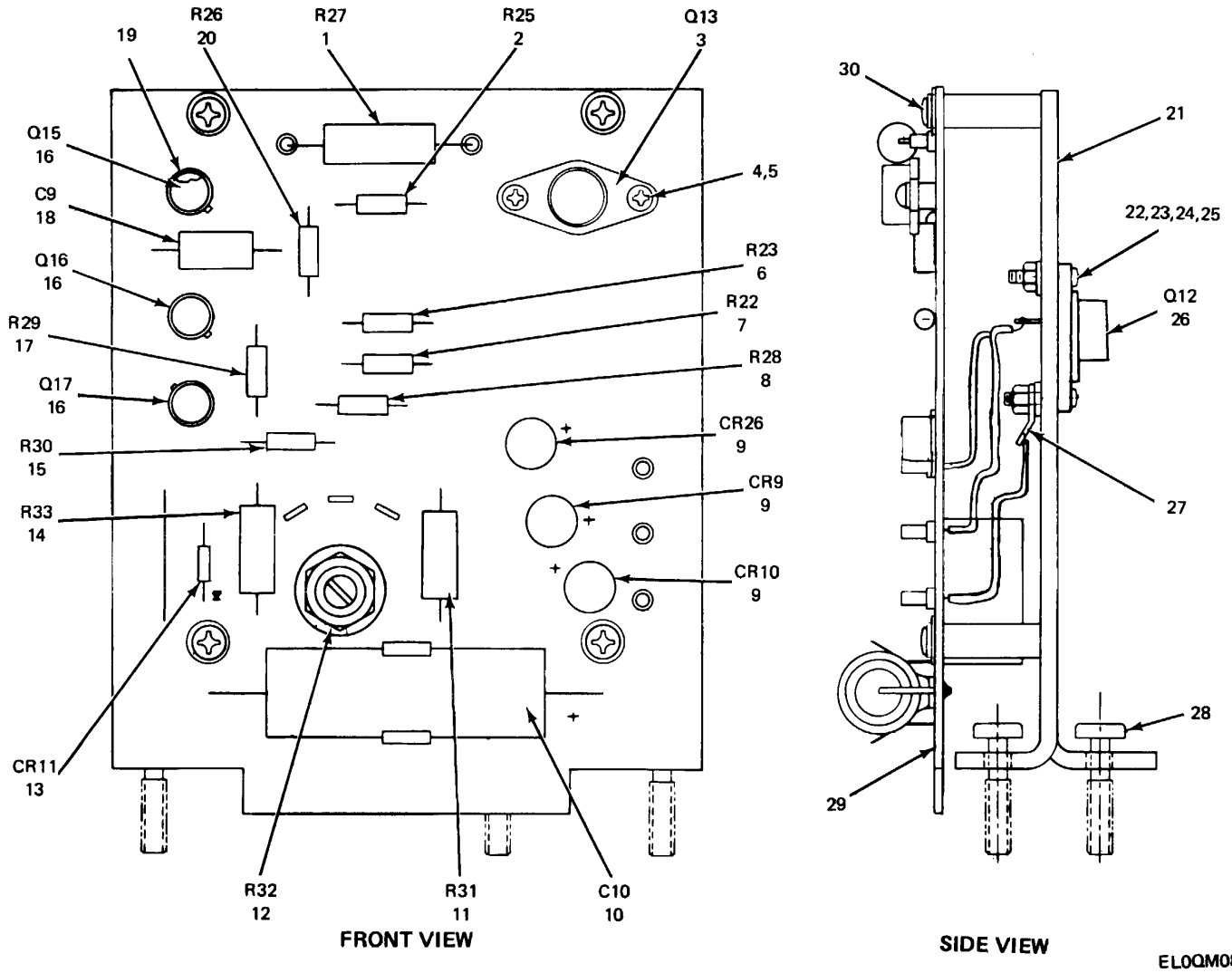
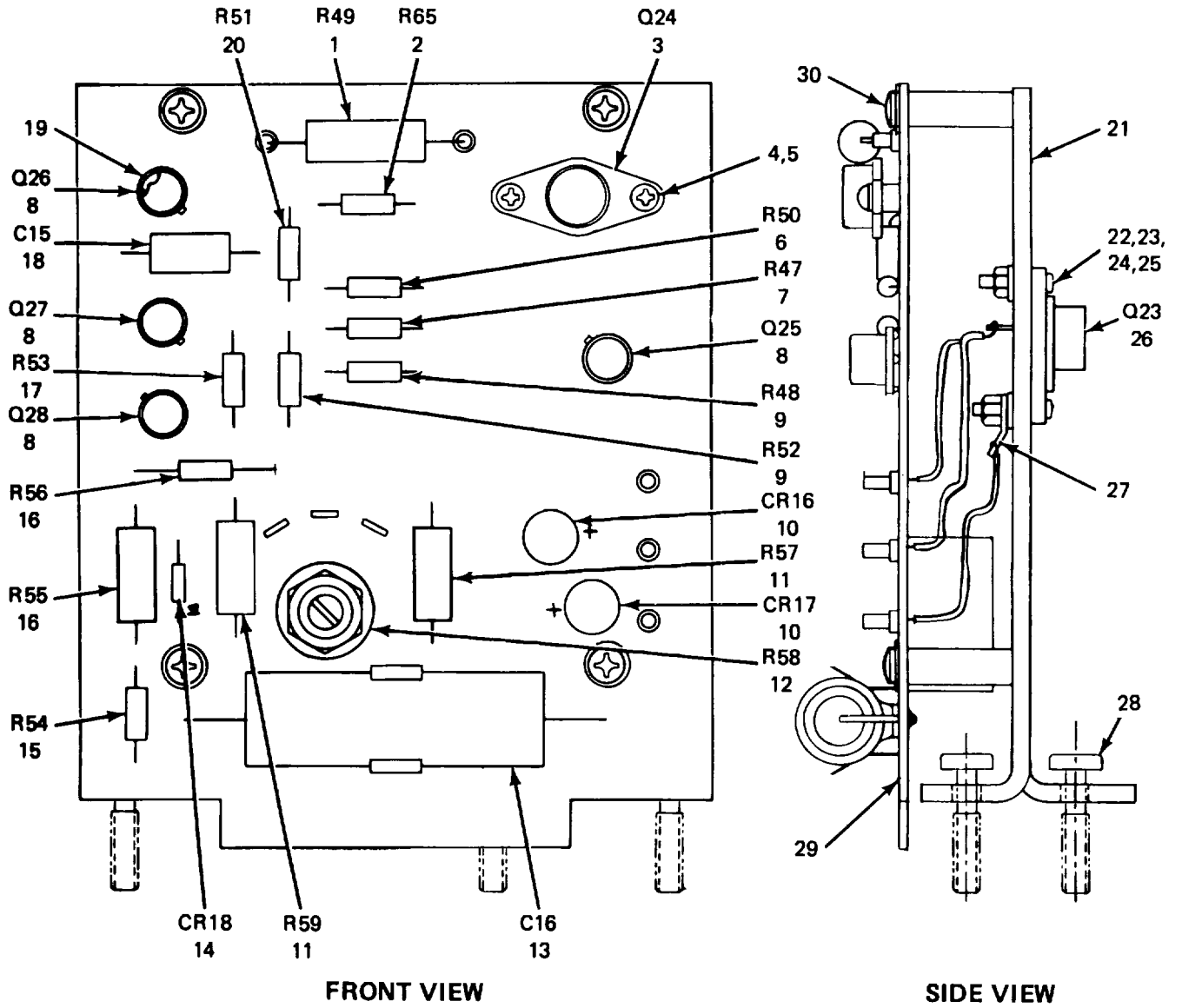

Figure 69. Circuit Card Assembly (12-890140-002).

SECTION II

TM 11-7440-222-40P/NAVELEX 0967-LP-324-0480/TO 31W4-2G-84

(1) ILLUSTRATION		(2)	(3)	(4)	(5)	(6) DESCRIPTION	(7)	(8)
(a) FIG NO.	(b) ITEM NO.	SMR CODE	NATIONAL STOCK NUMBER	PART NUMBER	FSCM	USABLE ON CODE	U/M	QTY INC IN UNIT
						GROUP 110104 CIRCUIT CARD ASSEMBLY (12-890140-002)		
69	1	XDDZZ		3X1	63743	RESISTOR, FIXED.....	EA	1
69	2	XDDZZ	5905-00-279-1756	RC20GF151K	81349	RESISTOR, FIXED, COMP.....	EA	1
69	3	PADZZ	5961-00-905-2926	40250	02735	TRANSISTOR.....	EA	1
69	4	PADZZ	5305-00-054-5647	MS51957-13	96906	SCREW, MACHINE.....	EA	4
69	5	PADZZ	5310-00-933-8118	MS35338-135	96906	WASHER, LOCK.....	EA	2
69	6	PADZZ	5905-00-279-2672	RC20GF182K	81349	RESISTOR, FIXED, COMP.....	EA	1
69	7	XDDZZ	5905-00-171-2002	RC20GF470K	81349	RESISTOR, FIXED, COMP.....	EA	1
69	8	PADZZ	5905-00-195-6502	RC20GF332K	81349	RESISTOR, FIXED, COMP.....	EA	1
69	9	XDDZZ	5961-00-827-4990	1N4997	04713	SEMICONDUCTOR DEVIC.....	EA	3
69	10	PADZZ	5910-00-929-7850	34D507G025FP4	56289	CAPACITOR, FIXED, ELE.....	EA	1
69	11	PADZZ	5905-00-764-9870	3X1300	63743	RESISTOR, FIXED, WIRE.....	EA	1
69	12	XDDZZ		29-479	12697	RESISTOR, VARIABLE.....	EA	1
69	13	PADZZ	5961-00-468-3651	1N751	81349	SEMICONDUCTOR, SPECI.....	EA	1
69	14	XDDZZ		3X470	63743	RESISTOR, FIXED.....	EA	1
69	15	PADZZ	5905-00-111-8357	RC20GF681K	81349	RESISTOR, FIXED, COMP.....	EA	1
69	16	PADZZ	5961-00-931-0385	RT9343	49956	TRANSISTOR.....	EA	3
69	17	PADZZ	5905-00-195-6817	RC20GF102K	81349	RESISTOR, FIXED, COMP.....	EA	1
69	18	PADZZ	5910-00-937-2052	V146XR001200V	50930	CAPACITOR, FIXED.....	EA	1
69	19	PADZZ	5999-00-946-0947	10079	07047	MOUNTING PAD, ELECTR.....	EA	1
69	20	XDDZZ	5905-00-190-8881	RC20GF182J	81349	RESISTOR, FIXED, COMP.....	EA	1
69	21	XDDZZ		01-003087-002	06809	HEATSINK.....	EA	1
69	22	PADZZ	5310-00-934-9761	MS35649-264	96906	NUT, PLAIN, HEXAGON.....	EA	2
69	23	PADZZ	5305-00-054-6655	MS51957-31	96906	SCREW, MACHINE.....	EA	2
69	24	PADZZ	5310-00-929-6395	MS35338-136	96906	WASHER, LOCK.....	EA	2
69	25	XDDZZ	5310-00-880-5976	MS15795-806	96906	WASHER, FLAT.....	EA	2
69	26	PADZZ	5961-00-249-1583	B3263A	13327	TRANSISTOR.....	EA	1
69	27	PADZZ	5940-00-827-2653	MS77068-2	96906	TERMINAL, LUG.....	EA	1
69	28	XDDZZ		01-003086-001	06809	SCREW, MACHINE.....	EA	2
69	29	XDDZZ		12-870140-001	06809	PRINTED CIRCUIT BD.....	EA	1
69	30	PADZZ	5305-00-054-6652	MS51957-28	96906	SCREW, MACHINE.....	EA	4



ELOQM081

Figure 70. Circuit Card Assembly (12-890143-001).

SECTION II

TM 11-7440-222-40P/NAVELEX 0967-LP-324-0480/TO 31W4-2G-84

(1) ILLUSTRATION		(2)	(3)	(4)	(5)	(6) DESCRIPTION	(7)	(8)
(a) FIG NO.	(b) ITEM NO.	SMR CODE	NATIONAL STOCK NUMBER	PART NUMBER	FSCM	USABLE ON CODE	U/M	QTY INC IN UNIT
						GROUP 110105 CIRCUIT CARD ASSEMBLY (12-890143-001)		
70	1	XDDZZ		7X.18	63743	RESISTOR, FIXED.....	EA	1
70	2	XDDZZ	5905-00-279-1869	RC20GF121K	81349	RESISTOR, FIXED, COMP.....	EA	1
70	3	PADZZ	5961-00-905-2926	40250	02735	TRANSISTOR.....	EA	1
70	4	XDDZZ	5305-00-054-5647	MS51957-13	96906	SCREW, MACHINE.....	EA	2
70	5	PADZZ	5310-00-933-8118	MS35338-135	96906	WASHER, LOCK.....	EA	2
70	6	PADZZ	5905-00-185-8518	RC20GF103K	81349	RESISTOR, FIXED, COMP.....	EA	1
70	7	XDDZZ	5905-00-279-2672	RC20GF182K	81349	RESISTOR, FIXED, COMP.....	EA	1
70	8	PADZZ	5961-00-931-0385	RT9343	49956	TRANSISTOR.....	EA	4
70	9	PADZZ	5905-00-279-1459	RC20GF150K	81349	RESISTOR, FIXED, COMP.....	EA	2
70	10	XDDZZ	5961-00-827-4990	1N4997	04713	SEMICONDUCTOR DEVIC.....	EA	2
70	11	PADZZ	5905-00-171-2006	RC20GF271J	81349	RESISTOR, FIXED, COMP.....	EA	2
70	12	XDDZZ		29-479	12697	RESISTOR, VARIABLE.....	EA	1
70	13	XDDZZ		34D907G010FL4	56289	CAPACITOR, FIXED, ELE.....	EA	1
70	14	PADZZ	5961-00-468-3651	1N751	81349	SEMICONDUCTOR, SPECI.....	EA	1
70	15	XDDZZ	5905-00-256-0409	RC20GF221K	81349	RESISTOR, FIXED, COMP.....	EA	1
70	16	XDDZZ		3X470	63743	RESISTOR, FIXED.....	EA	2
70	17	XDDZZ	5905-00-192-3972	RC20GF391K	81349	RESISTOR, FIXED, COMP.....	EA	1
70	18	XDDZZ		V146XR0068200V	04222	CAPACITOR, FIXED.....	EA	1
70	19	PADZZ	5970-00-946-0947	10079	07047	INSULATOR, DISK.....	EA	4
70	20	PADZZ	5905-00-171-2005	RC20GF471K	81349	RESISTOR, FIXED, COMP.....	EA	1
70	21	XDDZZ		01-003087-005	06809	HEATSINK.....	EA	1
70	22	PADZZ	5310-00-934-9761	MS35649-264	96906	NUT, PLAIN, HEXAGON.....	EA	2
70	23	PADZZ	5305-00-054-6655	MS51957-31	96906	SCREW, MACHINE.....	EA	2
70	24	PADZZ	5310-00-929-6395	MS35338-136	96906	WASHER, LOCK.....	EA	6
70	25	XDDZZ	5310-00-880-5976	MS15795-806	96906	WASHER, FLAT.....	EA	6
70	26	XDDZZ	5961-00-249-1583	B3263A	13327	TRANSISTOR.....	EA	1
70	27	PADZZ	5940-00-827-2653	MS77068-2	96906	TERMINAL, LUG.....	EA	1
70	28	XDDZZ		01-003086-001	06809	SCREW, MACHINE.....	EA	2
70	29	XDDZZ		12-870140-004	06809	PRINTED CIRCUIT BD.....	EA	1
70	30	PADZZ	5305-00-054-6652	MS51957-28	96906	SCREW, MACHINE.....	EA	4

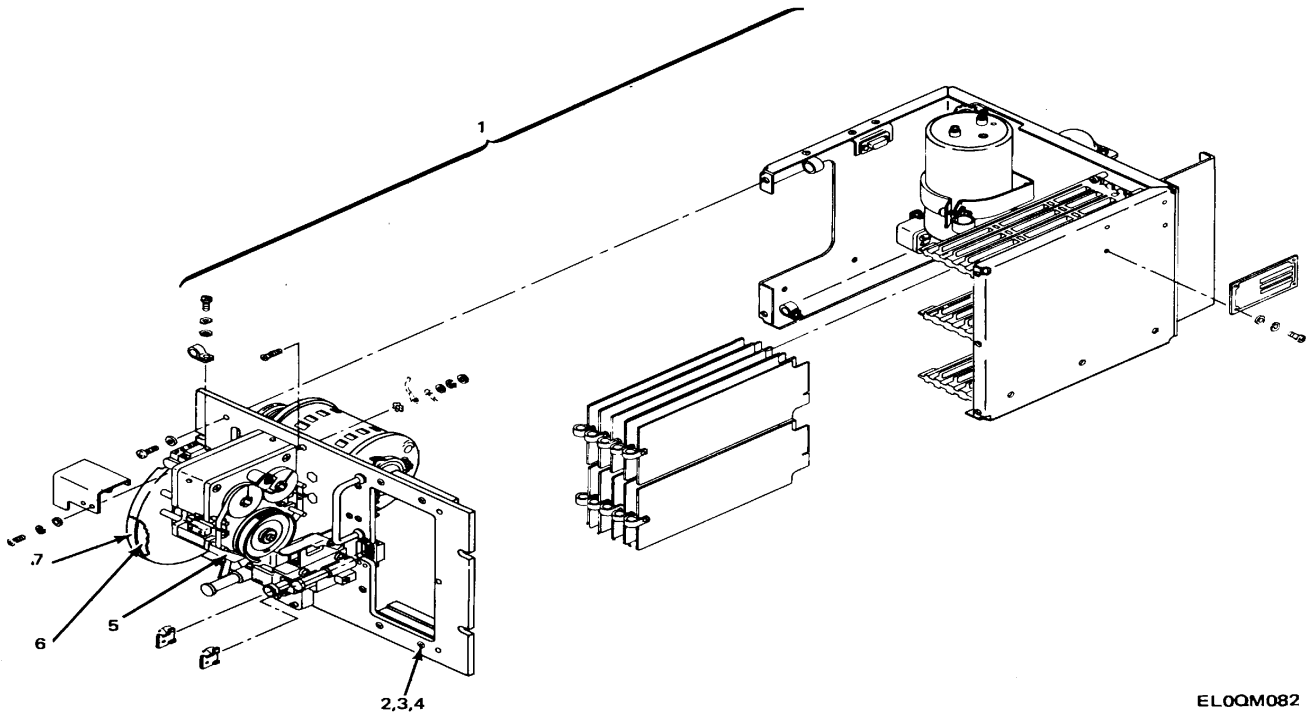
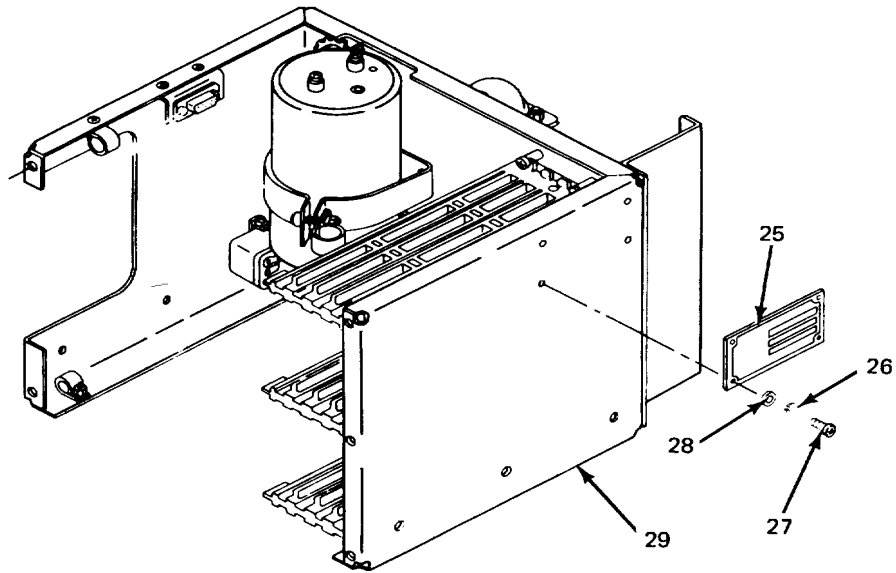
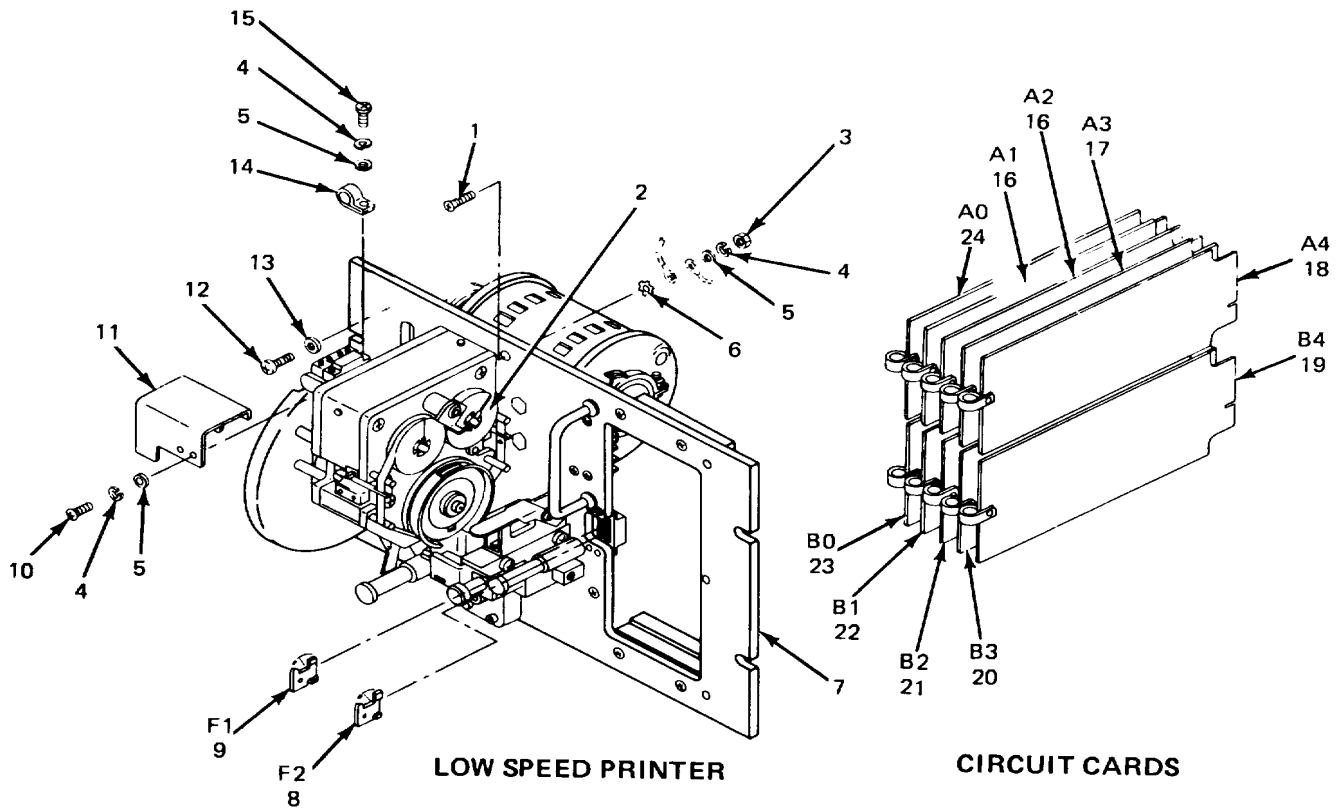

Figure 71. Printer Interpreter Assembly A3.

SECTION II

TM 11-7440-222-40P/NAVELEX 0967-LP-324-0480/TO 31W4-2G-84

(1) ILLUSTRATION		(2)	(3)	(4)	(5)	(6)	(7)	(8)
(a) FIG NO.	(b) ITEM NO.	SMR CODE	NATIONAL STOCK NUMBER	PART NUMBER	FSCM	DESCRIPTION USABLE ON CODE	U/M	QTY INC IN UNIT
						GROUP 12 PRINTER INTERPRETER ASSEMBLY A3		
71	1	PAHHH	7040-00-398-9646	52782G1	34631	LOW SP PTR INTPR.....	EA	1
71	2	PAHZZ	5305-00-059-3660	MS51958-64	96906	SCREW, MACHINE.....	EA	4
71	3	PAHZZ	5310-00-167-0812	AN960C10L	88044	WASHER, FLAT.....	EA	4
71	4	PAHZZ	5310-00-933-8120	MS35338-138	96906	WASHER, LOCK.....	EA	4
71	5	PAHZZ	7510-00-104-9334	56658-1	12436	RIBBON ASSEMBLY.....	EA	1
71	6	PAHZZ	7035-00-935-1338	30442	34631	CODE DISK, ITA 2.....	EA	1
71	7	PAHZZ	7035-00-926-7708	30441	34631	CODE DISK.....	EA	1



ELOQM083

Figure 72. Low Speed Printer Interpreter Assembly

(1) ILLUSTRATION		(2)	(3)	(4)	(5)	(6)	(7)	(8)
(a) FIG NO.	(b) ITEM NO.	SMR CODE	NATIONAL STOCK NUMBER	PART NUMBER	FSCM	DESCRIPTION USABLE ON CODE	U/M	QTY INC IN UNIT
						GROUP 1201 LOW SPEED PRINTER INTERPRETER ASSEMBLY		
72	1	PAHZZ	5305-00-765-4352	MS51959-31	96906	SCREW, MACHINE.....	EA	5
72	2	XDHZZ		52670-1	06809	SPOOL, RIBBON	EA	1
72	3	PAHZZ	5310-00-934-9761	MS35649-264	96906	NUT, PLAIN, HEXAGON.....	EA	1
72	4	PAHZZ	5310-00-929-6395	MS35338-136	96906	WASHER, LOCK	EA	2
72	5	PAHZZ	5310-00-531-9514	AN960C6	88044	WASHER, FLAT	EA	2
72	6	PAHZZ	5310-00-209-1366	1606-00	78189	WASHER, LOCK	EA	1
72	7	XDHHH		52899G1	06809	PANEL, ASSEMBLY.....	EA	1
72	8	PAHZZ	5920-00-901-9936	GMT1	71400	FUSE, INDICATOR ALAR	EA	1
72	9	PAHZZ	5920-00-702-6694	GMT1-4	71400	FUSE, INDICATOR ALAR	EA	1
72	10	PAHZZ	5305-00-054-6650	MS51957-26	96906	SCREW, MACHINE.....	EA	2
72	11	XDHZZ		56219-1	06809	COVER, CODE WHEEL.....	EA	1
72	12	PAHZZ	5305-00-054-6671	MS51957-46	96906	SCREW, MACHINE.....	EA	1
72	13	XDHZZ		933-118-010	06809	WASHER, FLAT, NYLON.....	EA	5
72	14	XDHZZ		NPC6	81074	CLAMP, LOOP	EA	2
72	15	PAHZZ	5305-00-054-6652	MS51957-28	96906	SCREW, MACHINE.....	EA	1
72	16	PAHDL	7025-00-852-6353	44193G2	12436	PRINTED CIRCUIT BOA.....	EA	2
72	17	PAHDL	7040-00-835-1300	44306G2	12436	PRINTED CIRCUIT BOA.....	EA	1
72	18	PAHDL	7025-00-852-6348	44194G2	12436	PRINTED CIRCUIT BOA.....	EA	1
72	19	PAHDL	7040-00-835-1318	44195G2	12436	PRINTED CIRCUIT BOA.....	EA	1
72	20	PAHDL	7440-00-937-3204	44196G2	12436	PRINTED CIRCUIT BOARD.....	EA	1
72	21	PAHDL	7040-00-019-3086	44452G2	12436	CIRCUIT CARD ASSEMB.....	EA	1
72	22	PAHDL	7025-00-852-6349	44197G2	12436	PRINTED CIRCUIT BOA.....	EA	1
72	23	PAHDL	7040-00-936-2323	34735G2	34631	CIRCUIT CARD ASSY	EA	1
72	24	PAHDL	7025-00-852-6351	44303G2	12436	PRINTED CIRCUIT BOA.....	EA	1
72	25	XDHZZ		01-003241-001	06809	PLATE, IDENT	EA	1
72	26	PAHZZ	5310-00-928-2690	MS35338-134	96906	WASHER, LOCK	EA	4
72	27	PAHZZ	5305-00-764-2966	MS51959-2	96906	SCREW, MACHINE.....	EA	4
72	28	PAHZZ	5310-00-183-4354	AN960C2L	88044	WASHER, FLAT	EA	4
72	29	XDHHH		52912G1	06809	CHASSIS, ELEC, EQPT.....	EA	1

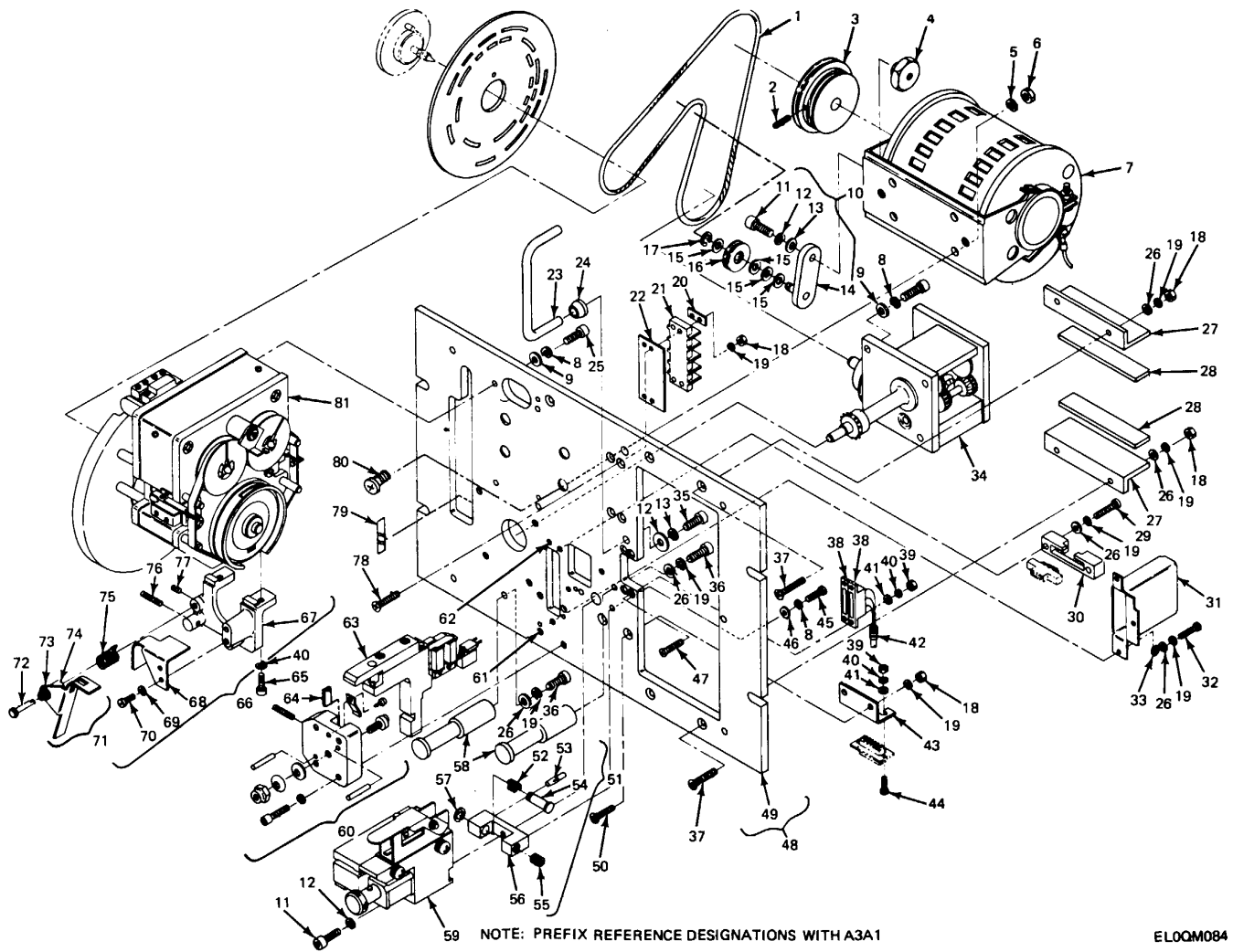

Figure 73. Panel Assembly A3A1.

(1) ILLUSTRATION		(2)	(3)	(4)	(5)	(6) DESCRIPTION	(7)	(8)
(a) FIG NO.	(b) ITEM NO.	SMR CODE	NATIONAL STOCK NUMBER	PART NUMBER	FSCM	USABLE ON CODE	U/M	QTY INC IN UNIT
						GROUP 120101 PANEL ASSEMBLY A3A1		
73	1	PAHZZ	3030-00-933-8564	10231-1	34631	BELT, DRIVE.....	EA	1
73	2	PAHZZ	5305-00-719-5339	MS51963-22	96906	SETSCREW	EA	2
73	3	XDHZZ		56044-1	06809	PULLEY, MOTOR.....	EA	1
73	4	XDHZZ		52872-1	06809	NUT, MOUNTING.....	EA	1
73	5	PADZZ	5310-00-933-8121	MS35338-139	96906	WASHER, LOCK.....	EA	1
73	6	XDDZZ		MS35691-416	96906	NUT, JAM, HEXAGON.....	EA	4
73	7	XDHDL		56223G1	06809	MOTOR ASSEMBLY.....	EA	1
73	8	PAHZZ	5310-00-933-8119	MS35338-137	96906	WASHER, LOCK.....	EA	2
73	9	PAHZZ	5310-00-685-3744	AN960C8	88044	WASHER, FLAT.....	EA	6
73	10	XDHHH		52945G1	06809	IDLER PUL SUBASSY.....	EA	1
73	11	PAHZZ	5305-00-052-6456	MS16996-10	96906	SCREW, CAP, SOCKET HE.....	EA	3
73	12	PAHZZ	5310-00-933-8120	MS35338-138	96906	WASHER, LOCK.....	EA	5
73	13	PAHZZ	5310-00-167-0801	AN960C10	88044	WASHER, FLAT.....	EA	5
73	14	XDHZZ		52870G1	06809	PLATE SUBASSY, MTG.....	EA	1
73	15	XDHZZ		10	02751	WASHER, NONMETALLIC.....	EA	1
73	16	PAHZZ	7040-00-019-1988	52873G1	12436	PULLEY BEARING.....	EA	1
73	17	XDHZZ	5365-00-200-6707	5133-18	79136	RING, RETAINING.....	EA	2
73	18	PAHZZ	5310-00-934-9761	MS35649-264	96906	NUT, PLAIN, HEXAGON.....	EA	3
73	19	PAHZZ	5310-00-929-6395	MS35338-136	96906	WASHER, LOCK.....	EA	4
73	20	PAHZZ	5940-00-502-8294	600SP	75382	LINK, TERMINAL CONNE.....	EA	2
73	21	PAHZZ	5940-00-983-6044	37TB3	81349	TERMINAL BOARD.....	EA	1
73	22	XDHZZ		MS4-140	71785	PLATE, DESIGNATION.....	EA	1
73	23	XDHZZ		1264-1	71279	HANDLE.....	EA	1
73	24	PAHZZ	5340-00-741-8569	1988-2	71279	FERRULE, HANDLE.....	EA	2
73	25	PAHZZ	5305-00-988-7604	MS16995-28	96906	SCREW, CAP, SOCKET HE.....	EA	4
73	26	PAHZZ	5310-00-531-9514	AN960C6	88044	WASHER, FLAT.....	EA	4
73	27	XDHZZ		52981-1	06809	SUPPORT, ANGLE.....	EA	1
73	28	XDHZZ		893-105-009	06809	TAPE, FOAM.....	EA	2
73	29	PAHZZ	5305-00-054-6655	MS51957-31	96906	SCREW, MACHINE.....	EA	2
73	30	XDHZZ		56514-1	06809	RETAINER, CONNECTOR.....	EA	1
73	31	XDHZZ		56555-1	06809	COVER, HMR MODIFIED.....	EA	1
73	32	PAHZZ	5305-00-054-6650	MS51957-26	96906	SCREW, MACHINE.....	EA	2
73	33	XDHZZ	5310-00-209-1366	MS35335-58	96906	WASHER, LOCK.....	EA	2
73	34	XDHDL		602040-1	12344	TAPE DRIVE ASSY.....	EA	1
73	35	PAHZZ	5305-00-959-1909	MS16996-11	96906	SCREW, CAP, SOCKET HE.....	EA	2
73	36	PAHZZ	5305-00-990-6381	MS16995-19	96906	SCREW, CAP, SOCKET HE.....	EA	2
73	37	PAHZZ	5305-00-765-4352	MS51959-31	96906	SCREW, MACHINE.....	EA	4
73	38	PAHZZ	5920-00-968-3238	HLT	71400	FUSEHOLDER, BLOCK.....	EA	2
73	39	PAHZZ	5310-00-271-4642	MS35649-44	96906	WASHER.....	EA	4

SECTION II

TM 11-7440-222-40P/NAVELEX 0967-LP-324-0480/TO 31W4-2G-84

(1) ILLUSTRATION		(2)	(3)	(4)	(5)	(6)	(7)	(8)
(a) FIG NO.	(b) ITEM NO.	SMR CODE	NATIONAL STOCK NUMBER	PART NUMBER	FSCM	DESCRIPTION USABLE ON CODE	U/M	QTY INC IN UNIT
73	40	PAHZZ	5310-00-933-8118	MS35338-135	96906	WASHER, LOCK	EA	4
73	41	PAHZZ	5310-00-782-1349	AN960C4	88044	WASHER, FLAT	EA	4
73	42	XDHHH		40639G1	06809	CABLE ASSEMBLY.....	EA	1
73	43	XDHZZ		52920-1	06809	BRACKET, CONNECTOR.....	EA	1
73	44	PAHZZ	5305-00-763-7822	MS51959-14	96906	SCREW, MACHINE.....	EA	2
73	45	PAHZZ	5305-00-054-6669	MS51957-44	96906	SCREW, MACHINE.....	EA	1
73	46	PAHZZ	5310-00-558-6207	AN960C8L	88044	WASHER, FLAT	EA	1
73	47	PAHZZ	5305-00-763-7827	MS51959-18	96906	SCREW, MACHINE.....	EA	6
73	48	XDHHH		56553G1	06809	PANEL ASSEMBLY.....	EA	1
73	49	XDHZZ		56554-1	06809	PANEL, BLANK	EA	1
73	50	XDHZZ	5305-00-719-5064	MS51959-30	96906	SCREW, MACHINE.....	EA	2
73	51	XDHHH		56517G1	06809	KEY SUBASSEMBLY.....	EA	1
73	52	XDHZZ		C240-026-0440	70472	SPRING, COMPRESSION.....	EA	1
73	53	XDHZZ		D1-8X1-4SS	83584	PIN, SELF-LOCKING	EA	1
73	54	XDHZZ		56375-1	06809	PIN, SPRING	EA	1
73	55	XDHZZ		MS51963-17	96906	SETSCREW	EA	1
73	56	XDHZZ		56377-1	06809	KEY, LOCATING	EA	1
73	57	PAHZZ	5365-00-200-6707	5133-18	79136	RING, RETAINING	EA	1
73	58	PAHZZ	7040-00-989-3618	333050	12344	ROLLER ASSEMBLY, PAP.....	EA	2
73	59	XDHHH		56388G2	06809	TAPE READER ASSY.....	EA	1
73	60	XDHHH		56369G1	06809	CLAMP SUBASSEMBLY.....	EA	1
73	61	PAHZZ	5340-00-141-6693	1185-2CNX164	01556	INSERT, SCREW THREAD	EA	8
73	62	PAHZZ	5340-00-682-1520	1185-06CNX207	01556	INSERT, SCREW THREAD	EA	5
73	63	PAHZZ	7040-00-019-2098	10-52907G1	12436	HAMMER MODULE ASSEM.....	EA	1
73	64	XDHZZ		56681-1	06809	GIB	EA	1
73	65	XDHZZ	5305-00-068-5414	MS16995-11	96906	SCREW, CAP, SOCKET HE	EA	1
73	66	XDHHH		56372G1	06809	SUPPORT, GUIDE ASSY	EA	1
73	67	XDHZZ		56373-1	06809	SUPPORT, TAPE.....	EA	1
73	68	XDHZZ		56074-1	06809	GUIDE, TAPE.....	EA	1
73	69	PAHZZ	5310-00-933-8118	MS35338-135	96906	WASHER, LOCK	EA	1
73	70	PAHZZ	5305-00-054-5649	MS51957-15	96906	SCREW, MACHINE.....	EA	1
73	71	XHHH		56368G1	06809	HOLDDOWN SUBASSY	EA	1
73	72	XDHZZ		52863-1	06809	PIN, HINGE	EA	1
73	73	PAHZZ	7040-00-036-3844	56370-1	34631	LEVER, HOLDDOWN	EA	1
73	74	XDHZZ		56070-1	06809	SPACER, SLEEVE.....	EA	1
73	75	PAHZZ	5360-00-926-5425	56092-1	34631	SPRING, TORSION.....	EA	1
73	76	XDHZZ		845-122-049	06809	SETSCREW	EA	1
73	77	PAHZZ	5305-00-719-5329	MS51963-20	96906	SETSCREW	EA	2
73	78	PAHZZ	5305-00-764-0064	MS51959-32	96906	SCREW, MACHINE.....	EA	4
73	79	XDHZZ		56979-1	06809	DECAL, BELT TENSION.....	EA	1

SECTION II

TM 11-7440-222-40P/NAVELEX 0967-LP-324-0480/TO 31W4-2G-84

(1) ILLUSTRATION		(2)	(3)	(4)	(5)	(6)	(7)	(8)
(a) FIG NO.	(b) ITEM NO.	SMR CODE	NATIONAL STOCK NUMBER	PART NUMBER	FSCM	DESCRIPTION USABLE ON CODE	U/M	QTY INC IN UNIT
73	80	PADZZ	5305-00-981-7614	MS16995-50	96906	SCREW,CAP,SOCKET HE	EA	4
73	81	XDHHH		52906G1	06809	RIBBON PR WHL ASSY	EA	1

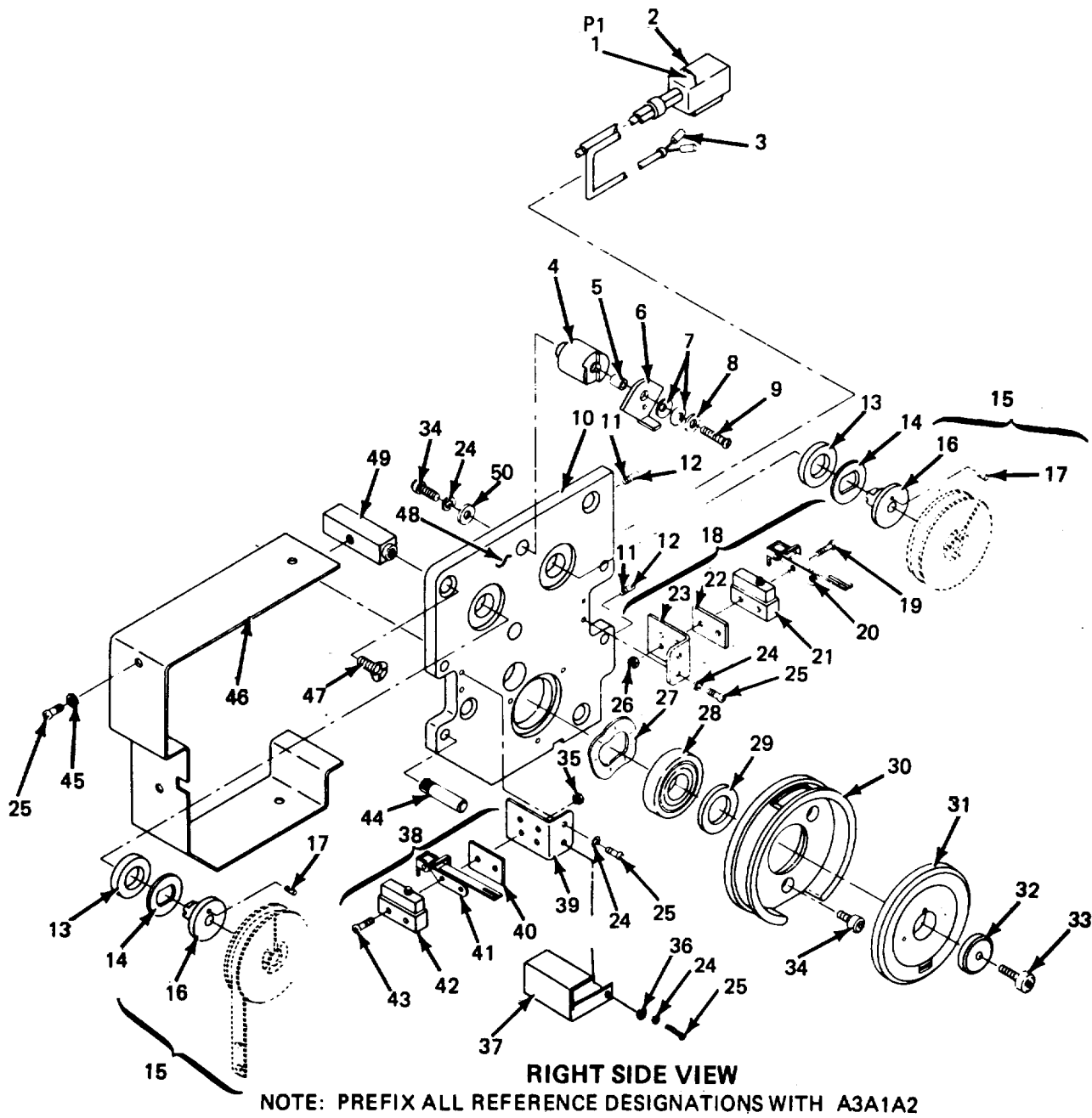

ELOQM085

Figure 74. Ribbon, Print Wheel Assembly A3A1A2 (Sheet 1 of 2).

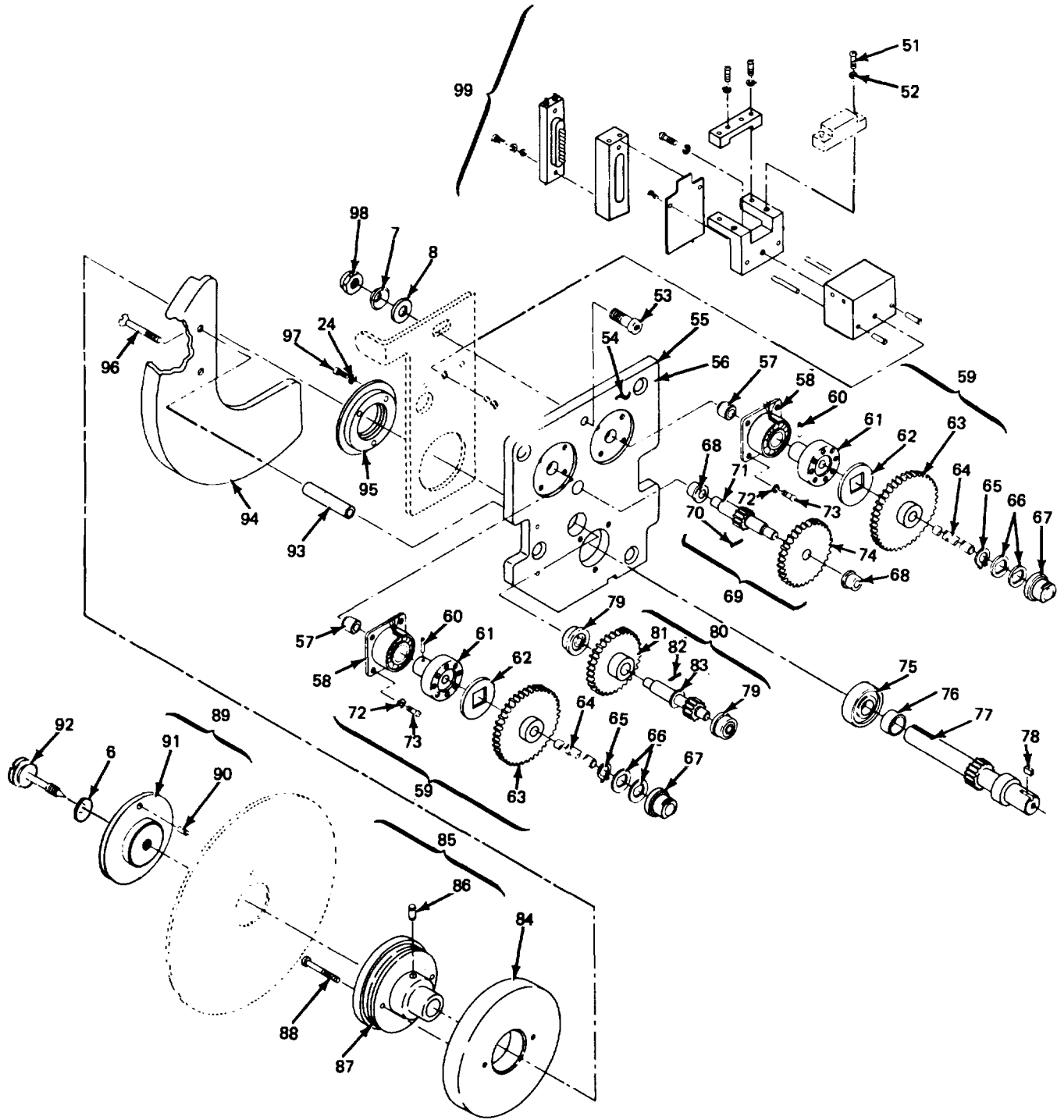

LEFT SIDE VIEW

NOTE: PREFIX ALL REFERENCE DESIGNATIONS WITH A3A1A2

ELOQM086

Figure 74. Ribbon, Print Wheel Assembly A3A1A2 (Sheet 2 of 2).

SECTION II

TM 11-7440-222-40P/NAVELEX 0967-LP-324-0480/TO 31W4-2G-84

(1) ILLUSTRATION		(2)	(3)	(4)	(5)	(6)	(7)	(8)
(a) FIG NO.	(b) ITEM NO.	SMR CODE	NATIONAL STOCK NUMBER	PART NUMBER	FSCM	DESCRIPTION USABLE ON CODE	U/M	QTY INC IN UNIT
						GROUP 12010101 RIRBON,PRINT WHEEL ASSEMBLY A3A1A2		
74	1	PAHZZ	5935-00-880-5441	DEM9P	71468	CONNECTOR,PLUG,ELEC	EA	1
74	2	PAHZZ	5935-00-816-8713	DE90JS19977-5	71468	SHIELD,ELECTRICAL C	EA	1
74	3	XDHZZ		60598-ILP	00779	CONTACT,ELECTRICAL	EA	4
74	4	XDHZZ		52877-1	06809	POST,RETAINER.....	EA	4
74	5	XDHZZ		52876-1	06809	SPACER,SLEEVE	EA	1
74	6	XDHZZ		52868-1	06809	RETAINER,SPOOL	EA	1
74	7	PAHZZ	5310-00-845-1894	375-15	92830	WASHER,SPRING TENSI	EA	7
74	8	PAHZZ	5310-00-167-0801	AN960C10	88044	WASHER,FLAT	EA	1
74	9	PAHZZ	5305-00-054-5651	MS51957-17	96906	SCREW,MACHINE.....	EA	1
74	10	XDHZZ		52666-1	06809	PLATE,HOUSING,RH	EA	1
74	11	PAHZZ	5340-00-297-3841	1185-2CNX246	01556	INSERT,SCREW THREAD	EA	4
74	12	XDHZZ		TYPED1-8X3-8SS	83584	PIN,GROOVED,HDLS.....	EA	2
74	13	XDHZZ		58877-1	06809	WASHER,COMPRESSION	EA	2
74	14	XDHZZ		52889-1	06809	WASHER,BEARING.....	EA	2
74	15	XDHHH		52641G1	06809	SLEEVE SUBASSY,DR.....	EA	2
74	16	XDHZZ		52641-1	06809	SLEEVE,DRIFT	EA	1
74	17	XDHZZ		B1-16X1-4SS	83584	PIN,GROOVED,HDLS.....	EA	1
74	18	XDHHH		52791G1	06809	SWITCH ASSEMBLY,LH	EA	1
74	19	PAHZZ	5305-00-054-5641	MS51957-7	96906	SCREW,MACHINE.....	EA	1
74	20	XDHZZ		5260501	06809	SWTTCH,ACTR,ASSY	EA	1
74	21	PAHZZ	5930-00-583-8861	11SM1T	91929	SWITCH,SENSITIVE	EA	1
74	22	XDHZZ		52620-1	06809	INSULATOR,SWITCH.....	EA	1
74	23	XDHZZ		52629-1	06809	BRACKET,MOUNTING	EA	3
74	24	PAHZZ	5310-0929-6395	MS35338-136	96906	WASHER,LOCK	EA	3
74	25	PAHZZ	5305-00-054-6652	MS51957-28	96906	SCREW,MACHINE.....	EA	2
74	26	XDHZZ	5310-00-938-2013	MS35649-24	96906	NUT,PLAIN,HEXAGON.....	EA	4
74	27	PAHZZ	5310-00-954-2353	R8	92830	WASHER,SPRING TENSI	EA	1
74	28	XDHZZ		Z97RBXR1CJ	43334	BEARING,BALL.....	EA	1
74	29	XDHZZ		52658-1	06809	SPACER,PRINT ROLL.....	EA	1
74	30	XDHZZ		52642-1	06809	PLATE,RETAINING.....	EA	1
74	31	PAHZZ	7040-00-019-2002	52661-1	12436	SEGMENT,ENGRAVED.....	EA	1
74	32	XDHZZ		52610-1	06809	CLAMP,WASHER	EA	1
74	33	PAHZZ	5305-00-052-6456	MS16996-10	96906	SCREW,CAP,SOCKET HE	EA	1
74	34	PAHZZ	5305-00-959-0382	MS16995-17	96906	SCREW,CAP,SOCKET,HE	EA	1
74	35	XDHZZ	5310-00-938-2013	MS35649-24	96906	NUT,PLAIN,HEXAGON	EA	4
74	36	PAHZZ	5310-00-638-9857	AN960C6L	8044	WASHER,FLAT	EA	1
74	31	DHZZ		11265	106809	COVER,SWTCH.....	EA	1
74	38	XDHHH		52790G1	06809	SWITCH SUBASSY,RH	EA	1

SECTION II

TM 11-7440-222-40P/NAVELEX 0967-LP-324-0480/TO 31W4-2G-84

(1) ILLUSTRATION		(2)	(3)	(4)	(5)	(6)	(7)	(8)
(a) FIG NO.	(b) ITEM NO.	SMR CODE	NATIONAL STOCK NUMBER	PART NUMBER	FSCM	DESCRIPTION USABLE ON CODE	U/M	QTY INC IN UNIT
74	39	XDHZZ		52629-1	06809	BRACKET,MOUNTING	EA	2
74	40	XDHZZ		526201	06809	INSULATOR,SWITCH	EA	3
74	41	XDHZZ		52605G1	06809	SWITCH ASSY,ACTR	EA	1
74	42	PAHZZ	5930-00-583-8861	11SM1T	91929	SWITCH,SENSITIVE	EA	1
74	43	PAHZZ	5305-00-054-5641	MS51957-7	96906	SCREW,MACHINE	EA	2
74	44	XDHZZ		52887-1	06809	POST,RIBBON GUIDE	EA	4
74	45	XDHZZ		933-107-102	06809	WASHER,NONMETALLIC	EA	2
74	46	XDHZZ		52996-1	06809	COVER,INTERPRETER	EA	1
74	47	PAHZZ	5305-00-071-1322	MS51960-65	96906	SCREW,MACHINE	EA	2
74	48	XDHHH		52666G1	06809	PLATE SUBASSY,RH	EA	1
74	49	XDHZZ		52991-1	06809	STANDOFF	EA	4
74	50	PAHZZ	5310-00-531-9514	AN960C6	88044	WASHER,FLAT	EA	1
74	51	PAHZZ	5305-00-054-5649	MS51957-15	96906	SCREW,MACHINE	EA	2
74	52	PAHZZ		1204-03	81891	WASHER,LOCK	EA	2
74	53	PAHZZ	5305-00-958-6517	MS16996-12	96906	SCREW,CAP,SOCKET HE	EA	1
74	54	XDHHH		52661G1	06809	PLATE SUBASSY.LH	EA	1
74	55	XDHZZ		52665-1	06809	PLATE HOUSING,LH	EA	1
74	56	PAHZZ	5340-00-291-3841	1185-2CNX246	01556	INSERT,SCREW THREAD	EA	4
74	57	PAHZZ	3120-00-434-1467	52924-1	34631	BUSHING,SLEEVE	EA	2
74	58	PAHZI	7040-00-019-4699	86509207-1	16554	FIELD,ASSEMBLY	EA	2
74	59	XDHHH		52681G1	06809	CLUTCH ASSEMBLY	EA	2
74	60	PAHZZ	5315-00-8437988	52-012-062-0312	12962	PIN,SPRING	EA	1
74	61	PAHZZ	7040-00-019-4687	B6509207-2	1654	ROTOR,ARMATURE	EA	1
74	62	PAHZZ	7040-00-019-0976	56646-1	34631	PLATE,ARMATURE	EA	1
74	63	PAHZZ	7040-00-019-0922	52517-1	34631	GEAR,CLUTCH	EA	1
74	64	PAHZZ	7440-00-324-4451	52549-1	34631	SHAFT,DRIVE	EA	1
74	65	PAHZZ	5365-00263-5954	5108031	79136	RINIG,RETAINING	EA	2
74	66	XDHZZ		52888-1	06809	WASHERFLAT	EA	4
74	67	XDHZZ		52865-1	06809	BUSHING,FLANGED	EA	2
74	68	PAHZZ	3120-00-55-7544	FB35-2	71041	BEARING,SLEVE	EA	2
74	69	PAHHH	7040-00-134-192	52647G1	34631	SHAFT SUBASSEMBLY	EA	1
74	70	XDHZZ		RPB062-059-437	72962	ROLL,PIN	EA	2
74	71	XDHZZ		5253-1	06809	SHAFT,PINION	EA	1
74	74	PAHZZ	5317-00-92-26902	MS35338-134	96906	WASHER,LOCK	EA	8
74	75	PAHZZ	5305-00-068-5410	MS16995-2	96906	SCREW,CAP,SOCKET,HEAD	EA	8
74	76	XDHZZ		52539-1	06809	GEAR,SPUR	EA	1
74	75	PAHZZ	3110-00-975-2051	Z97R6XR1CJ	43334	BEARING,BALL,ANNULA	EA	1
74	76	PAHZZ	5365-00-480-2420	52646-1	34631	SPACER,BEARING	EA	1
74	74	XDHZZ		52619-2	06809	SHAFT,PRINT ROLL	EA	1
74	78	XDHZZ		52948-1	06809	KEY,MACHINE	EA	1

SECTION II

TM 11-7440-222-40P/NAVELEX 0967-LP-324-0480/TO 31W4-2G-84

(1) ILLUSTRATION		(2)	(3)	(4)	(5)	(6)	(7)	(8)
(a) FIG NO.	(b) ITEM NO.	SMR CODE	NATIONAL STOCK NUMBER	PART NUMBER	FSCM	DESCRIPTION USABLE ON CODE	U/M	QTY INC IN UNIT
74	79	XDHZZ		FR33MM	83086	BEARING,FLANGED.....	EA	2
74	80	XDHHH		5357661	06809	GEAR SUBASSY,PINION	EA	1
74	81	PAHZZ	7040-00-019-0866	52575-1	34631	GEAR,DRIVE	EA	1
74	82	XDHZZ		RPB062-059-437	72962	ROLL PIN	EA	2
74	83	PAHZZ	7035-00-043-1238	52571-1	12436	PINION SHAFT,WHEEL.....	EA	1
74	84	XDHZZ		56359-1	06809	FLYHEEL,DRIVE.....	EA	1
74	85	XDHHH		56679G1	06809	PULLEY SUBASSEBLY	EA	1
74	86	XDHZZ		C1-8X1-4SS	83584	PIN GROOVED	EA	2
74	87	XDHZZ		52639-1	06809	PULEY,DRIVE.....	EA	1
74	88	PAHZZ	5305-00-988-7605	MS16995-29	96906	SCREW,CAP,SOCKET	EA	2
74	89	XDHHH		52640G1	06809	CLAMP SUBASSY,DISK.....	EA	1
74	90	XDHZZ		TYPEB1-8X3-8SS	83584	PIN,GROOVED,HDLS.....	EA	1
74	91	XDHZZ		52640-1	06809	CLAMP,DISK.....	EA	1
74	92	XDHZZ		6193SS0832	06540	SCREW,EXTERNALLY RE	EA	1
74	93	XDHZZ		52964-1	06809	SPACERSLEEVE	EA	2
74	94	XDHZZ		56671-1	06809	GUARD,CODE DISK.....	EA	1
74	95	XDHZZ		52612-1	06809	PLATE,RETAINER	EA	1
74	96	PAHZZ	5305-00-764-0080	MS51959-52	96906	SCREW,MACHINE.....	EA	2
74	97	PAHZZ	5305-00-959-1082	MS16995-18	96906	SCREW,CAP,SOCKET HE	EA	3
74	98	PAHZZ	5310-00-208-9255	79NM02	72962	NUT, SELF-LOCKING,HE	EA	2
74	99	XDHHH		52940G1	06809	BRACKET ASSY.PH ADJ	EA	1

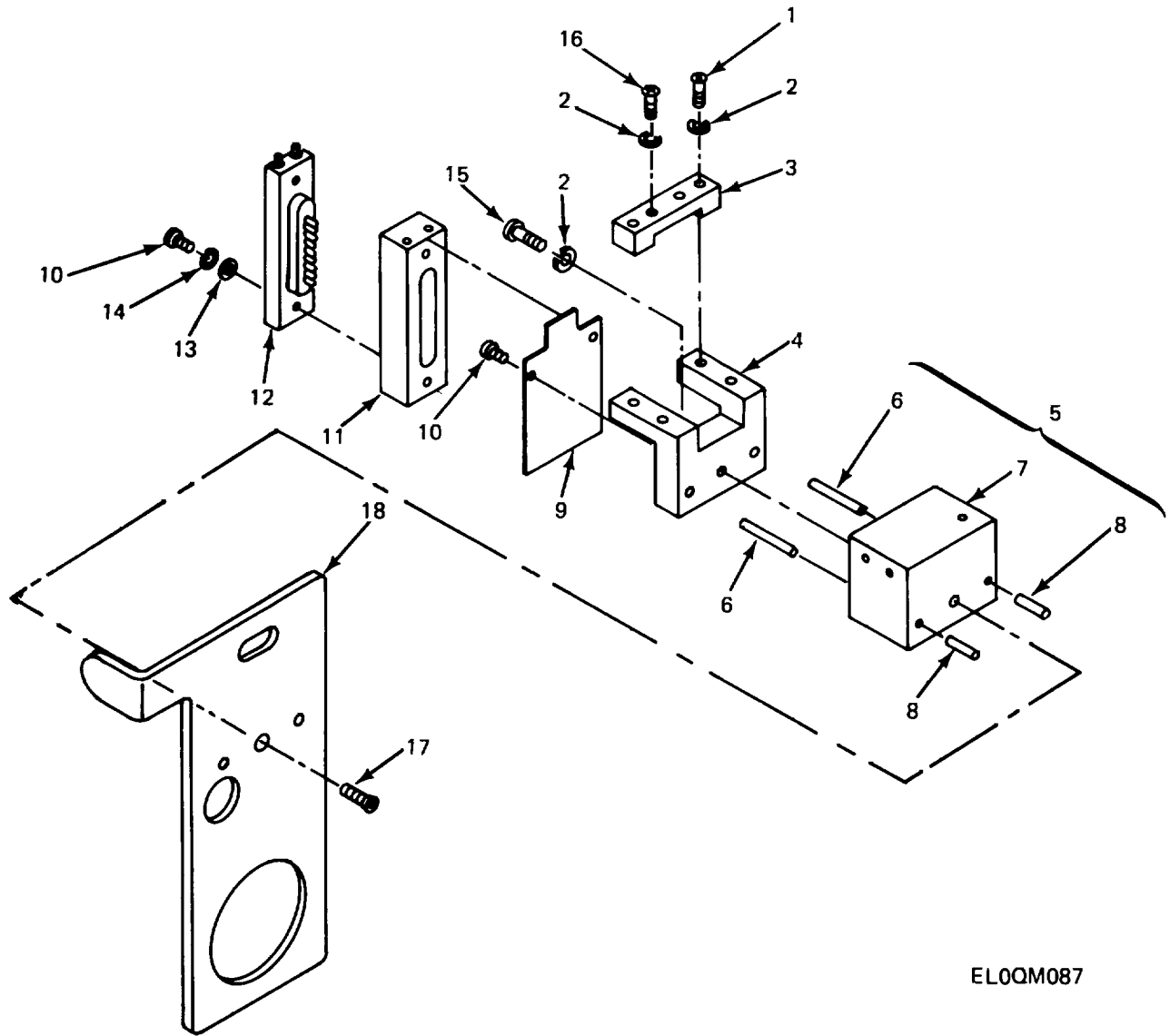

EL0QM087

Figure 75. Bracket Assembly, Phase Adjusting.

SECTION II

TM 11-7440-222-40P/NAVELEX 0967-LP-324-0480/TO 31W4-2G-84

(1) ILLUSTRATION		(2)	(3)	(4)	(5)	(6) DESCRIPTION	(7)	(8)
(a) FIG NO.	(b) ITEM NO.	SMR CODE	NATIONAL STOCK NUMBER	PART NUMBER	FSCM	USABLE ON CODE	U/M	QTY INC IN UNIT
						GROUP 1201010101 BRACKET ASSEMBLY, PHASE ADJUSTING		
75	1	PAHZZ	5305-00-05-6653	MS51957-29	96906	SCREW,MACHINE.....	EA	1
75	2	PAHZZ	5310-00-929-6395	MS35338-136	96906	WASHER,LOCK.....	EA	1
75	3	XDHZZ		56407G1	06809	BRACKET ASSY,HSG.....	EA	1
75	4	XDHZZ		5265-2	06809	BRACKET MOUNTING.....	EA	1
75	5	XDHHH		52682G1	06809	BLOCK ASSEMBLY.....	EA	1
75	6	XDHZZ		TYPD-8X3-SS	83584	PIN,GROOVED,HDLS.....	EA	2
75	7	XDHZZ		52682-1	06809	BLOCK,AODAPTER.....	EA	1
75	8	XDHZZ		TYPEDIX3-8SS	83584	PIN,GROOVED,HDLS.....	EA	2
75	9	PAHZZ	7040-00-019-1002	56516GI	34631	LIGHT SENSOR ASSY.....	EA	1
75	10	PAHZZ	5305-00-054-5649	M551957-15	96906	SCREW,MACHINE.....	EA	1
75	11	XDHZZ		56497-1	06809	HOUSING,LAMP.....	EA	1
75	12	PAHZZ	7025-00-075-6778	00-001592-I	12436	CIRCUIT CARD ASSEMB.....	EA	2
75	13	PAHZZ	5310-00-782-1349	AN960C4	88044	WASHER,FLAT.....	EA	1
75	14	XDHZZ		1204-03	78189	WASHER,LOCK.....	EA	7
75	15	PAHZZ	5305-00-959-1082	MS16995-18	96906	SCREW,CAP,SOCKET.....	EA	2
75	16	PAHZZ	5305-00-054-6652	MS51957-28	96906	SREW,MACHINE.....	EA	1
75	17	PAHZZ	5305-00-763-6963	MS51959-28	96906	SREW,MACHINE.....	EA	3
75	18	XDHZZ		56680-2	96906	BRACKET,MOUNTING.....	EA	1

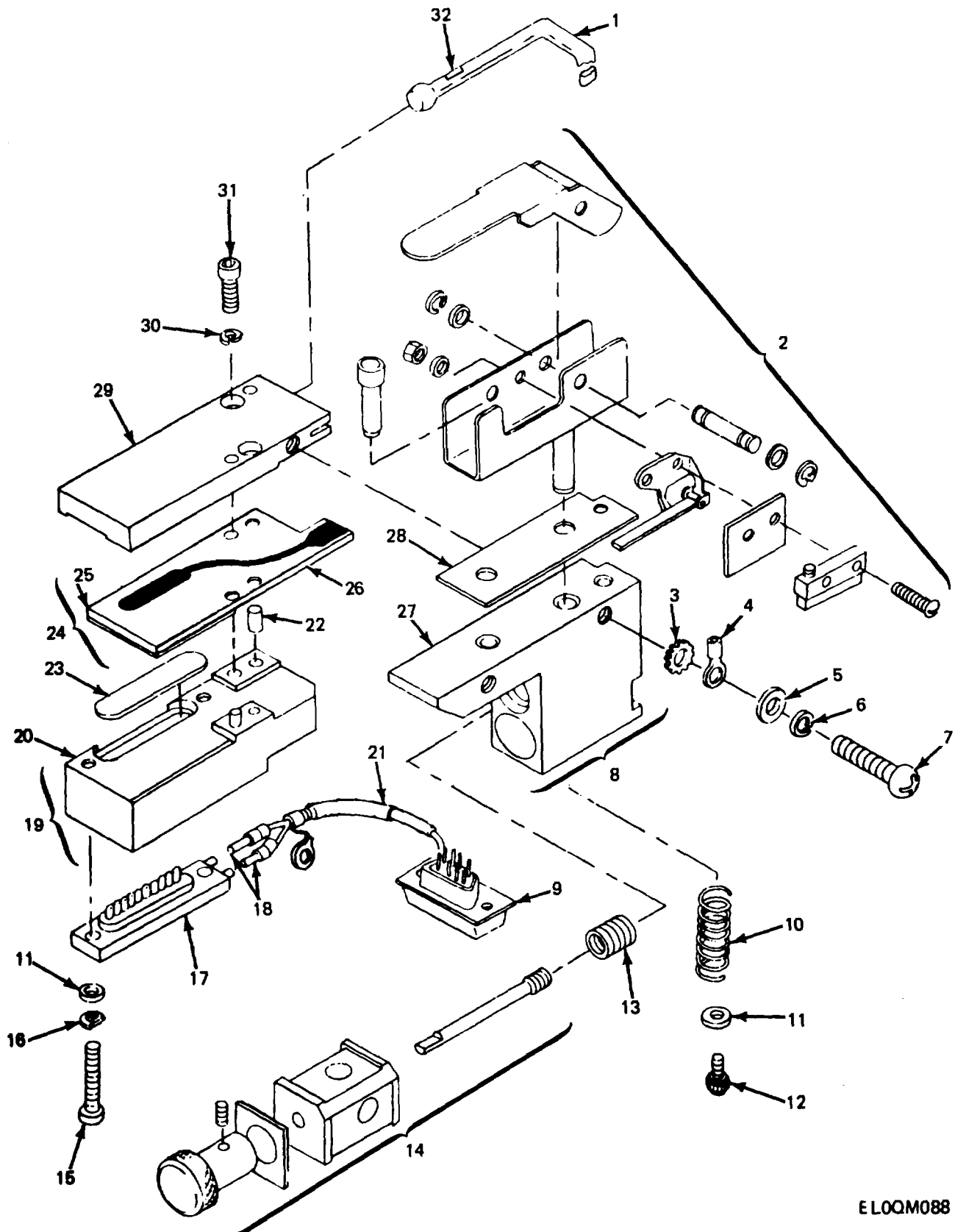

ELOQM088

Figure 76. Tape Reader Assembly

SECTION II

TM 11-7440-222-40P/NAVELEX 0967-LP-324-0480/TO 31W4-2G-84

(1) ILLUSTRATION		(2)	(3)	(4)	(5)	(6) DESCRIPTION	(7)	(8)
(a) FIG NO.	(b) ITEM NO.	SMR CODE	NATIONAL STOCK NUMBER	PART NUMBER	FSCM	USABLE ON CODE	U/M	QTY INC IN UNIT
						GROUP 12010102 TAPE READER ASSEMBLY		
76	1	XDHHH		56675G6	06809	WIRING HARNESS.....	EA	1
76	2	XDHHH		52978G1	06809	SWITCH SUBASSEMBLY.....	EA	1
76	3	PAHZZ	5310-00-614-3552	MS35335-59	96906	WASHER,LOCK.....	EA	1
76	4	XDHZZ		R1980M	02032	TERMINAL,INSULATED.....	EA	2
76	5	PAHZZ	5310-00-685-3744	AN960C8	88044	WASHER,FLAT.....	EA	1
76	6	PAHZZ	5310-00-933-8119	MS35338-137	96906	WASHER,LOCK.....	EA	1
76	7	PAHZZ	5305-00-054-6674	MS51957-49	96906	SCREW,MACHINE.....	EA	2
76	8	XDHHH		56380G1	06809	BLOCK SUBASSY,MTG.....	EA	1
76	9	PAHZZ	5935-00-880-5441	DEM9P	71468	CONNECTOR,RECEPTACL.....	EA	1
76	10	XDHZZ		C300-026-1000S	92830	SPRING,CPRSN.....	EA	1
76	11	PAHZZ	5310-00-782-1349	AN960C4	88044	WASHER,FLAT.....	EA	3
76	12	PAHZZ	5305-00-068-5276	MS16995-9	96906	SCREW,CAP,SOCKET HE.....	EA	1
76	13	XDHZZ		1185-3CNX90	01556	INSERT,SCREW THREAD.....	EA	1
76	14	PAHHH	7040-00-852-6354	56116G1	34631	TAPE ADJUST SUBASSY.....	EA	1
76	15	PAHZZ	5305-00-054-5649	MS51957-15	96906	SCREW,MACHINE.....	EA	1
76	16	PAHZZ	5310-00-933-8118	S35338-135	96906	WASHER,LOCK.....	EA	1
76	17	XDHZZ	7025-00-075-6778	00-001592-1	12436	CIRCUIT CARD ASSEMBLY.....	EA	1
76	18	XDHZZ		60598-1LP	00779	CONTACT,ELECTRICAL.....	EA	2
76	19	XDHHH		56511G1	06809	SUPPORT ASSY,LOWER.....	EA	1
76	20	XDHZZ		56511-1	06809	SUPPORT.....	EA	1
76	21	XDHZZ		56626-1	06809	MARKER,CABLE.....	EA	1
76	22	XDHZZ		DI-8X3-8S	83584	PIN,SELF-LOCKING.....	EA	2
76	23	PAHZZ	7040-00-019-2146	59335-1	34631	FILTER,INFRARED.....	EA	1
76	24	PAHZZ	7040-00-157-8672	56648G2	12436	SENSOR ASSEMBLY LIG.....	EA	1
76	25	XDHZZ		56645-1	06809	COVER,APERTURE.....	EA	1
76	26	PAHZZ	7040-00-019-2004	56519G2	12436	LIGHT SENSOR ASSEMB.....	EA	1
76	27	XDHZZ		56380-1	06809	BLOCK.....	EA	1
76	28	XDHZZ		52962-1	06809	PLATE,WEAR.....	EA	1
76	29	XDHZZ		56510-1	06809	SUPPORT,UPPER.....	EA	1
76	30	XDHZZ		5615-1	06809	WASHER,FLAT.....	EA	2
76	31	PAHZZ	5305-00-068-5414	MS16995-11	96906	SCREW,CAP,SOCKET HE.....	EA	2
76	32	PAHZZ	5905-00-845-4708	31E2	83186	RESISTOR,THERMAL.....	EA	1

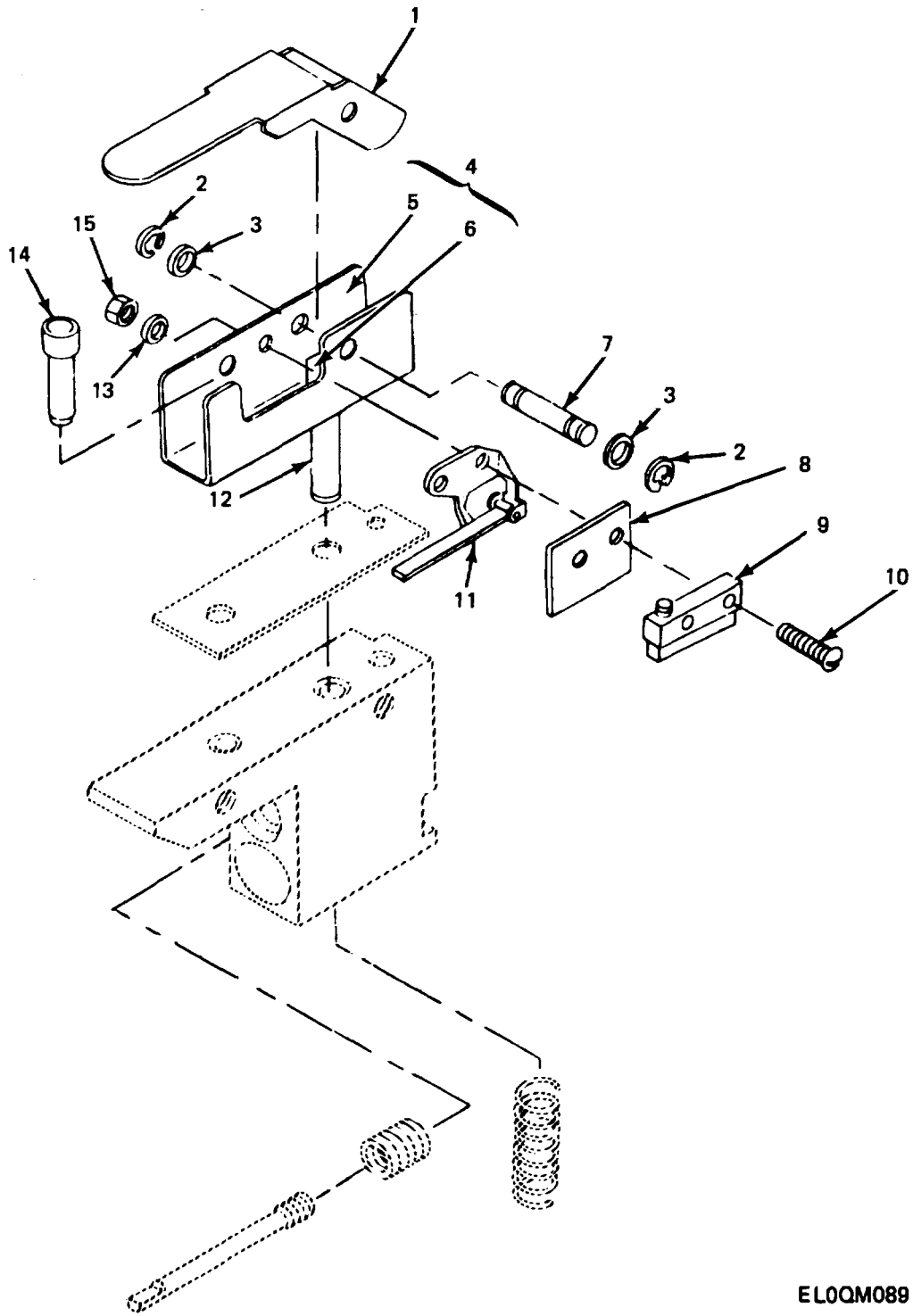

EL0QM089

Figure 77. Switch Subassembly.

SECTION II

TM 11-7440-222-40P/NAVELEX 0967-LP-324-0480/TO 31W4-2G-84

(1) ILLUSTRATION		(2)	(3)	(4)	(5)	(6)	(7)	(8)
(a) FIG NO.	(b) ITEM NO.	SMR CODE	NATIONAL STOCK NUMBER	PART NUMBER	FSCM	DESCRIPTION USABLE ON CODE	U/M	QTY INC IN UNIT
						GROUP 1201010201 SWITCH SUBASSEMBLY		
77	1	PAHZZ	7035-00-043-1325	52802-1	12436	LEVER,LIFTING	EA	1
77	2	PAHZZ	5365-00-282-5322	5133-12	79136	RING,RETAINING	EA	2
77	3	XDHZZ		AN960C5	88044	WASHER,FLAT	EA	2
77	4	XDHHH		52977G1	06809	SWITCH,MT SUBASSY	EA	1
77	5	XDHZZ		52810-1	06809	BRACKET,MOUNTING	EA	1
77	6	XDHZZ		52797-1	06809	POST,SPRING RTNR	EA	1
77	7	XDHZZ		52806-1	06809	PIN,LEVER.....	EA	1
77	8	XDHZZ		52620-1	06809	INSULATOR,SWITCH.....	EA	1
77	9	PAHZZ	5930-00-583-8861	11SM1T	91929	SWITCH,SENSITIVE.....	EA	1
77	10	PAHZZ	5305-00-054-5641	MS51957-7	96906	SCREW,MACHINE.....	EA	1
77	11	PAHZZ	5930-00-670-7164	JS220	91929	ADAPTER,SWITCH ACTU.....	EA	1
77	12	XDHZZ		52804-2	06809	PIN,GUIDE	EA	2
77	13	PAHZZ	5310-00-167-0797	AN960C2	88044	WASHER,FLAT	EA	4
77	14	XDHZZ		52798-1	06809	PIN,PLUNGER	EA	1
77	15	PAHZZ	5310-00-938-2013	MS35649-224	96906	NUT,PLAIN,HEXAGON.....	EA	1

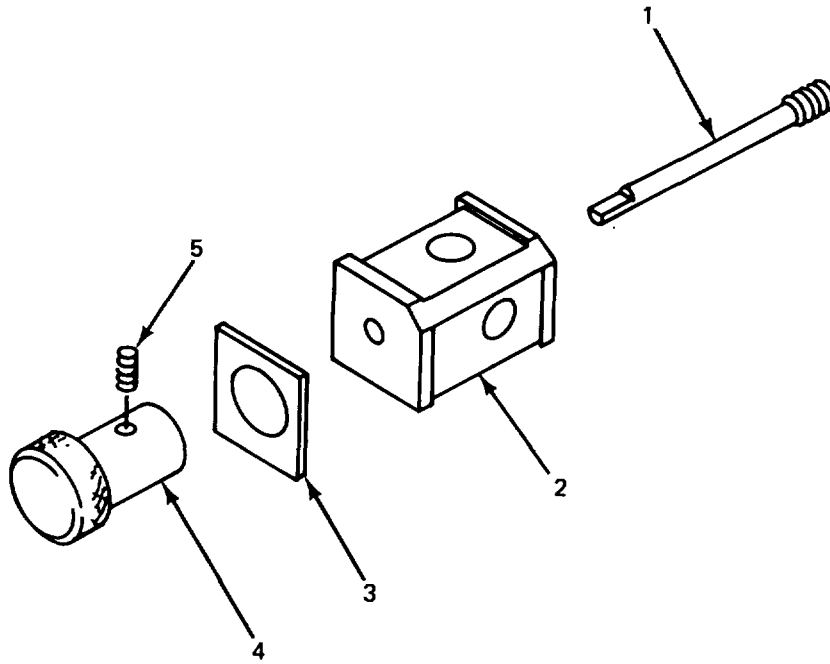

ELOQM090

Figure 78. Tape Adjust Subassembly.

SECTION II

TM 11-7440-222-40P/NAVELEX 0967-LP-324-0480/TO 31W4-2G-84

(1) ILLUSTRATION		(2)	(3)	(4)	(5)	(6) DESCRIPTION	(7)	(8)
(a) FIG NO.	(b) ITEM NO.	SMR CODE	NATIONAL STOCK NUMBER	PART NUMBER	FSCM	USABLE ON CODE	U/M	QTY INC IN UNIT
						GROUP 1201010202 TAPE ADJUST SUBASSEMBLY		
78	1	XDHZZ		52799-1	06809	SHAFT,TAPE GUIDE	EA	1
78	2	XDHZZ		52796-L	06809	GUIDE,TAPE	EA	1
78	3	XDHZZ		56115-1	06809	DECAL,TAPE GUIDE	EA	1
78	4	PAHZZ	5355-00-018-4533	52800-1	34631	KNOB,ADJUST	EA	1
78	5	PAHZZ	5305-00-719-5329	MS51963-20	96906	SETSCREW	EA	1

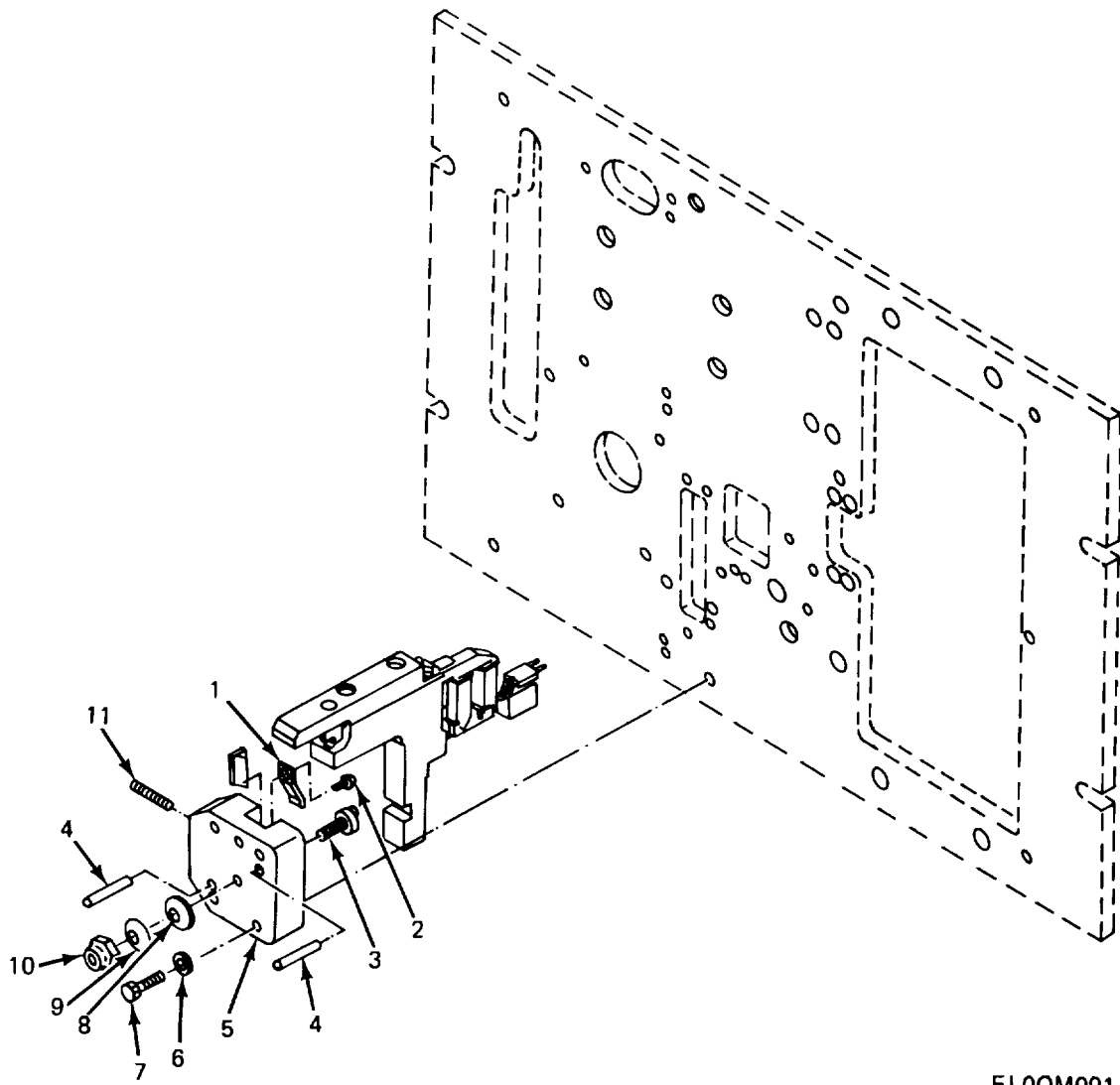

ELOQM091

Figure 79. Clamp Subassembly.

SECTION II

TM 11-7440-222-40P/NAVELEX 0967-LP-324-0480/TO 31W4-2G-84

(1) ILLUSTRATION		(2)	(3)	(4)	(5)	(6) DESCRIPTION	(7)	(8)
(a) FIG NO.	(b) ITEM NO.	SMR CODE	NATIONAL STOCK NUMBER	PART NUMBER	FSCM	USABLE ON CODE	U/M	QTY INC IN UNIT
						GROUP 12010103 CLAMP SUBASSEMBLY		
79	1	XDHZZ		56255-1	06809	CLIP,SPRING TENSION	EA	1
79	2	XDHZZ		TYPEU2X1-8	70318	SCREW,DRIVE	EA	1
79	3	PAHZZ	5305-00-137-3445	56010-1	34631	SCREW,ADJUSTING	EA	1
79	4	XDHZZ		TYPEB1-8X3-4	83584	PIN,GROOVED,HDLS	EA	2
79	5	XDHZZ		56365G1	06809	BLOCK,CLAMP	EA	1
79	6	PAHZZ	5310-00-933-8119	MS35338-137	96906	WASHER,LOCK	EA	4
79	7	PAHZZ	5305-00-988-7603	MS16995-27	96906	SCREW,CAP,SOCKET HE	EA	4
79	8	PAHZZ	5310-00-933-8121	MS35338-139	96906	WASHER,LOCK	EA	1
79	9	PAHZZ	5310-00-845-1894	375-15	92830	WASHER,SPRING TENSI	EA	1
79	10	PAHZZ	5310-00-208-9255	79NM02	72962	NUT,SELF-LOCKING,HE	EA	4
79	11	XDHZZ		845-101-088	06809	SETSCREW	EA	1

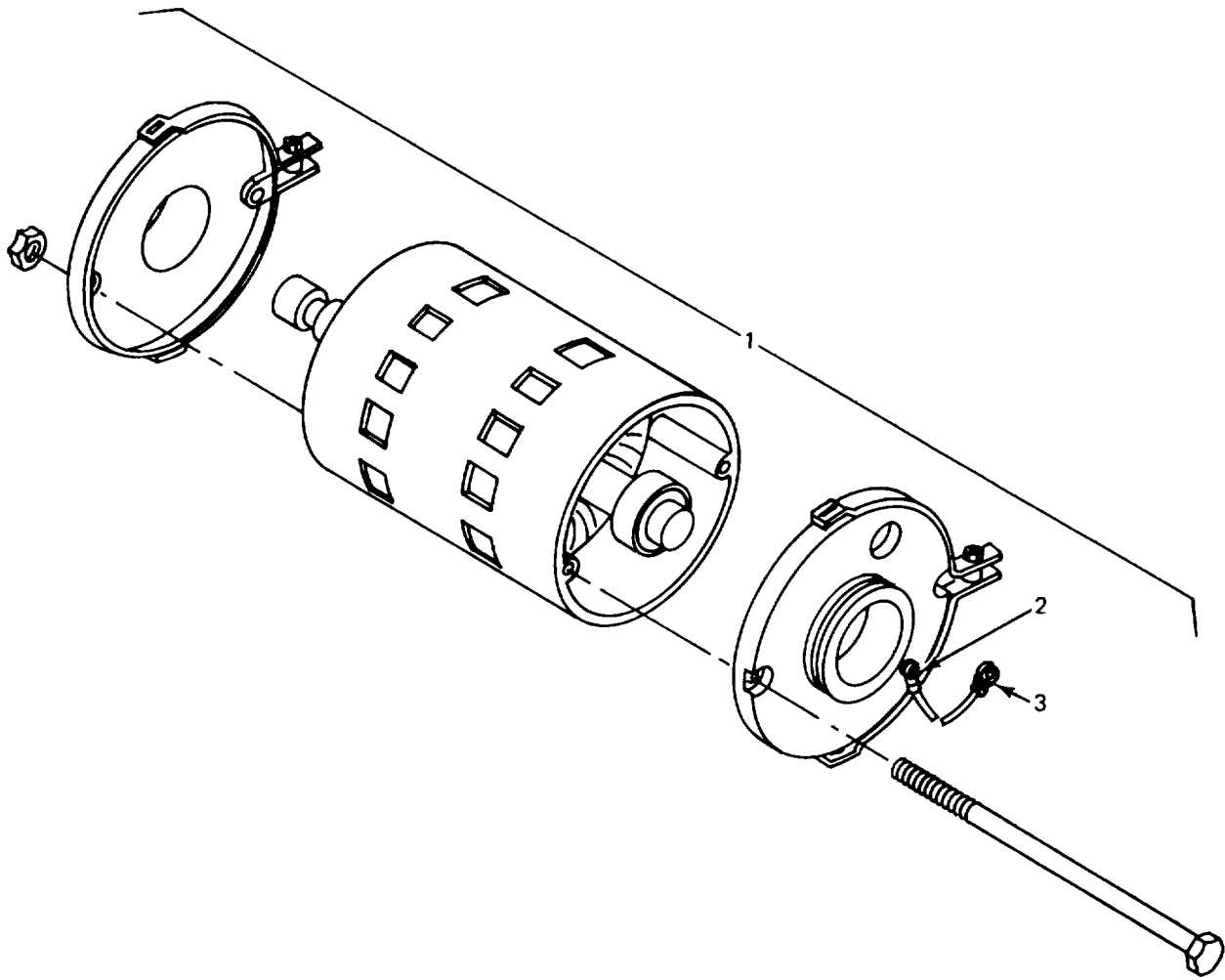

EL0QM092

Figure 80. Motor Assembly.

SECTION II

TM 11-7440-222-40P/NAVELEX 0967-LP-324-0480/TO 31W4-2G-84

(1) ILLUSTRATION		(2)	(3)	(4)	(5)	(6)	(7)	(8)
(a) FIG NO.	(b) ITEM NO.	SMR CODE	NATIONAL STOCK NUMBER	PART NUMBER	FSCM	DESCRIPTION USABLE ON CODE	U/M	QTY INC IN UNIT
80	1	PADZZ	6105-00-789-3741	5KH14FG106T	03510	GROUP 12010104 MOTOR ASSEMBLY		
80	2	XDDZZ		RB863	02032	MOTOR,ALTERNATING C.....	EA	1
80	3	PADZZ	5940-00-578-0905	RB1203	59730	TERMINAL,LUG	EA	7
						TERNINAL,LUG	EA	11

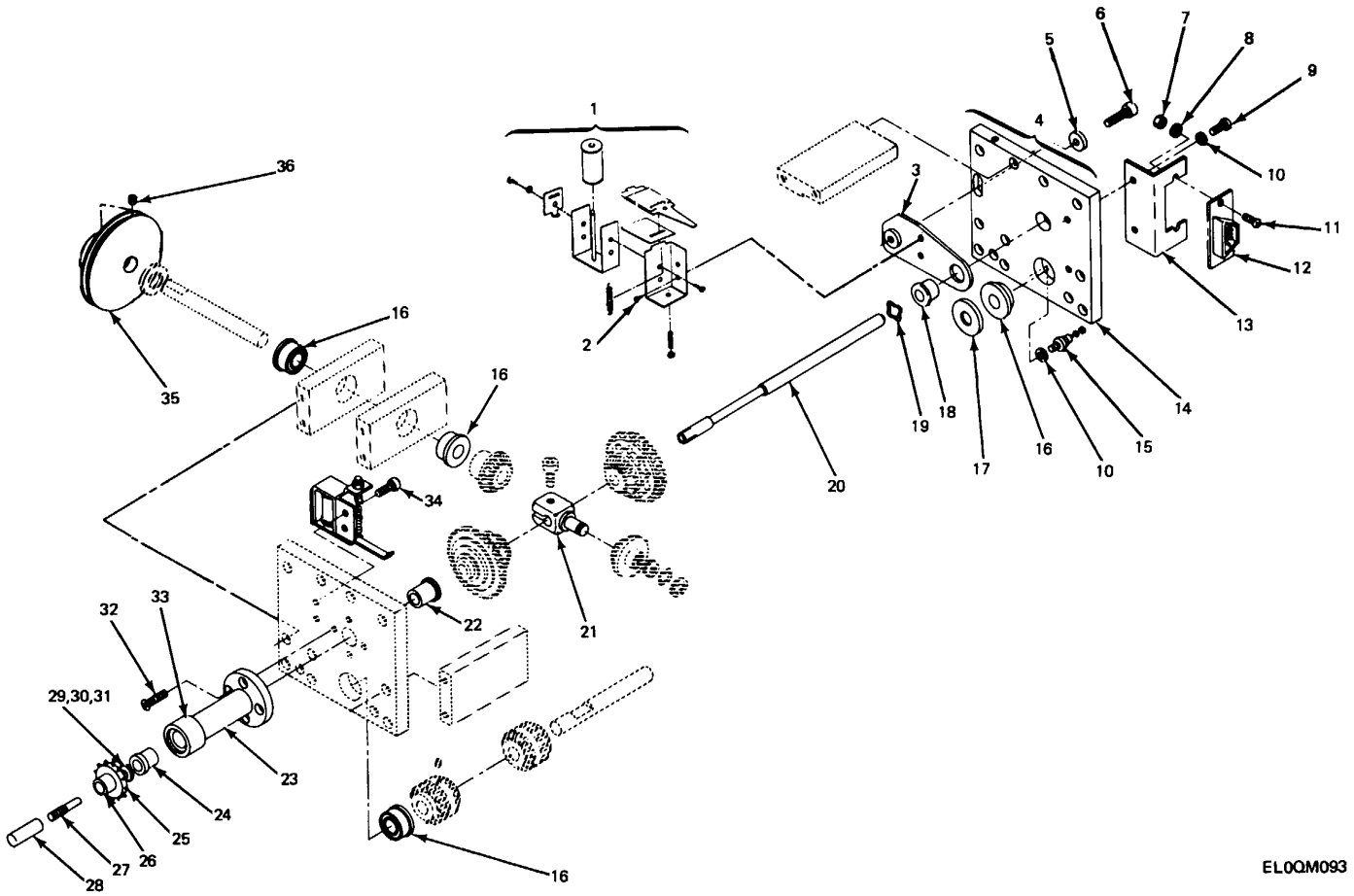

ELOQM093

Figure 81. Tape Drive Assembly.

SECTION II

TM 11-7440-222-40P/NAVELEX 0967-LP-324-0480/TO 31W4-2G-84

(1) ILLUSTRATION		(2)	(3)	(4)	(5)	(6) DESCRIPTION	(7)	(8)
(a) FIG NO.	(b) ITEM NO.	SMR CODE	NATIONAL STOCK NUMBER	PART NUMBER	FSCM	USABLE ON CODE	U/M	QTY INC IN UNIT
						GROUP 12010105 TAPE DRIVE ASSEMBLY		
81	1	XDHHL		356270	12344	MAGNETIC ACTR ASSY.....	EA	1
81	2	XDDZZ		314370	12344	SCREW,CAP,SOCKET HE	EA	2
81	3	XDDZZ		333960	12344	PLATE CPSN ADJ ASSY	EA	1
81	4	XDHDL		602093-1	12344	FRAME ASSEMBLY	EA	1
81	5	XDDZZ		400216-09	12344	WASHER,PLAIN	EA	2
81	6	PADZZ	5305-00-686-5973	304182	12344	SCREW,CAP,SOCKET HE	EA	1
81	7	XDDZZ		4171900	12344	NUT,PLAIN,HEXACGON	EA	2
81	8	XDDZZ		7SU5795-803	96906	WASHER,PLAIN	EA	2
81	9	PADZZ	5305-00-054-6650	MS51957-26	96906	SCREW,MACHINE.....	EA	2
81	10	PADZZ	5310-00-616-3555	MS35333-71	96906	WASHERLOCK	EA	2
81	11	PADZZ	5305-00-054-5648	MS51957-14	96906	SCREW,MACHINE.....	EA	2
81	12	XDDZZ		400498-11	12344	CONNECTOR,RCPT.ELEC.....	EA	1
81	13	XDDZZ		602072-1	12344	BRACKET,CONNECTOR.....	EA	1
81	14	XDDZZ		602092-1	12344	FRAME	EA	1
81	15	XDDZZ		400595-01	12344	TERMINAL,INSULATED	EA	1
81	16	PADZZ	3110-00-870-6931	396820	12344	BEARING,BALL,ANNULA	EA	4
81	17	XDDZZ		400009-05	12344	WASHER,THRUST	EA	1
81	18	PADZZ	3120-00-931-8695	229030	12344	BUSHING,SLEEVE	EA	1
81	19	PADZZ	5310-00-701-9130	304282	12344	WASHER, SPRING TENS!	EA	2
81	20	XDDZZ		333950	12344	SHIFT	EA	1
81	21	PAHDL	6605-00-987-7693	216830	12344	SPIDER,DIFFERENTIAL.....	EA	1
81	22	PADZZ	7040-00-087-8495	304216	12344	BUSHING	EA	1
81	23	XDDZZ		333930	12344	TUBE	EA	1
81	24	PADZZ	6605-00-835-5131	304211	12344	BUSHING,FLANGED	EA	1
81	25	XDHDL		300300	12344	CAPSTAN ASSEMBLY	EA	1
81	26	XDDZZ		329900	12344	INSERT	EA	1
81	27	PADZZ	5315-00-937-9653	300640	12344	PIN,SPECIAL	EA	1
81	28	PADZZ	7440-00-054-3423	31640	112344	CAP,COLLET PIN	EA	1
81	2q	PADZZ	5365-00-178-6043	225372	12344	SHIM.....	EA	1
81	30	PADZZ	5365-0-057-7778	8225371	12344	SHIM.....	EA	1
81	31	PADZZ	5365-00-52-1080	225S373	12344	SHIM.....	EA	1
81	34	XDDZZ		4155900	12344	SCREW,MACHINE.....	EA	4
81	33	XDDZZ		333940	12344	COLLAR	EA	1
81	34	XDDZZ		4155050	12344	SCREW	EA	2
81	35	XDDZZ		602071-1	12344	PULLEY,DRIVE	EA	1
81	36	PADZZ	5305-00-719-5339	MS51963-22	96906	SETSCREW	EA	1

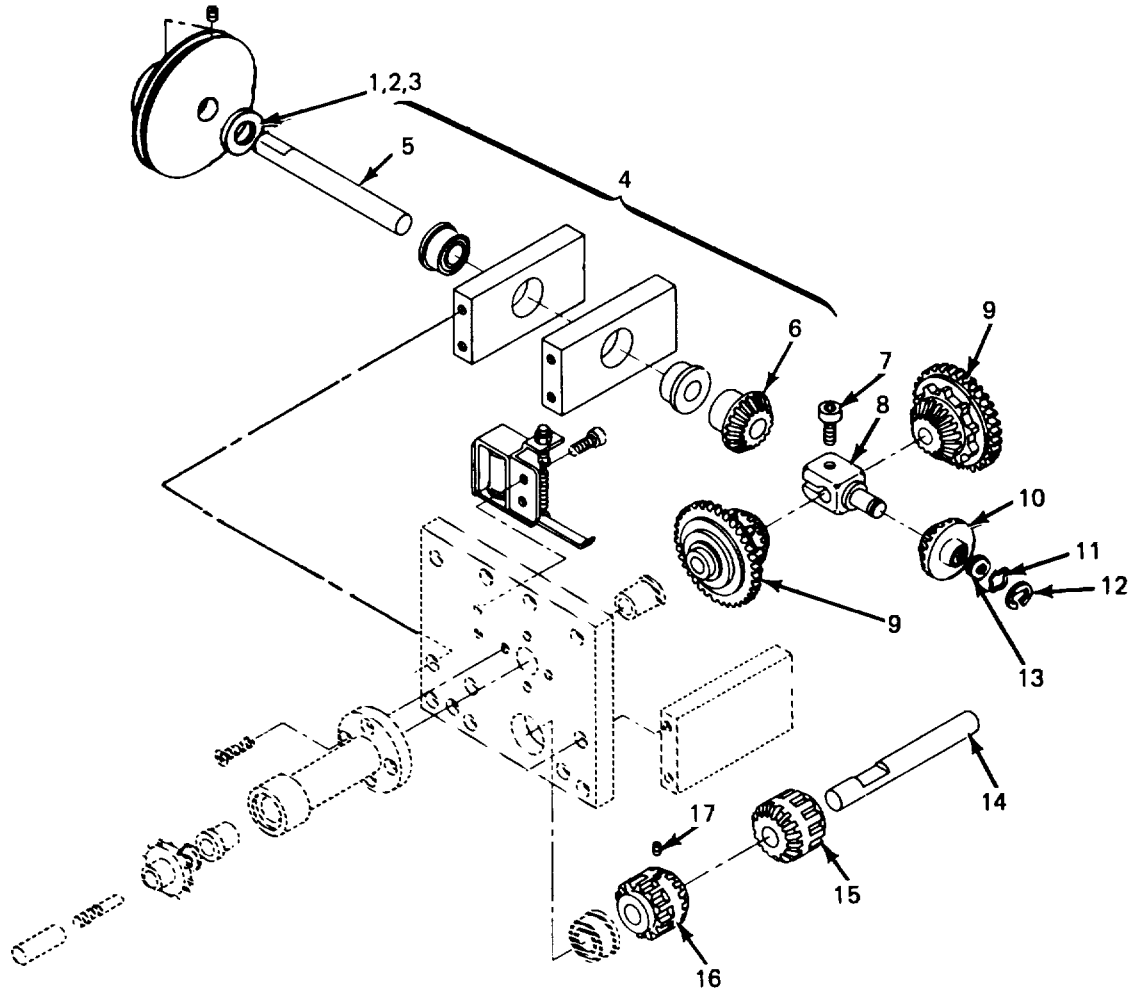

SPIDER DIFFERENTIAL

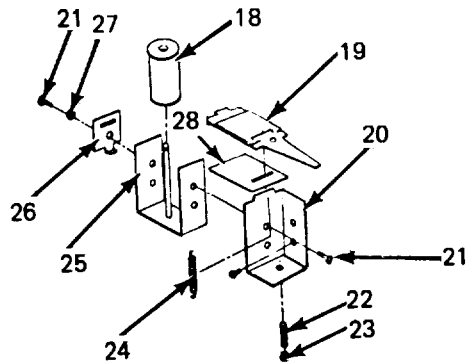

MAGNETIC ACTUATOR

EL0QM094

Figure 82. SPIDER Assembly, Differential and Magnetic Actuator Assembly, Reverse L2.

SECTION II

(1) ILLUSTRATION		(2)	(3)	(4)	(5)	(6) DESCRIPTION	(7)	(8)
(a) FIG NO.	(b) ITEM NO.	SMR CODE	NATIONAL STOCK NUMBER	PART NUMBER	FSCM	USABLE ON CODE	U/M	QTY INC IN UNIT
						GROUP 1201010501 SPIDER ASSEMBLY		
82	1	PADZZ	5365-00-178-6044	225374	12344	SHIM.....	EA	1
82	2	PADZZ	5365-00-178-6045	225375	12344	SHIM.....	EA	1
82	3	PADZZ	5365-00-182-6731	225376	12344	SHIM.....	EA	1
82	4	PADDL	7440-00-407-0744	333910	12344	GEAR AND SHAFT ASSE.....	EA	1
82	5	XDDZZ		33900	12344	SHAFT.....	EA	1
82	6	XDDZZ		J215842	123A4	BEVEL GEAR MOLDED.....	EA	1
82	17	PADZZ	5305-00-959-0382	MHS16995-17	96906	SCREW,CAP,SOCKET,HE.....	EA	1
82	8	XDDZZ		135550	12344	CLAMP DIFFERENTIAL.....	EA	1
82	9	PADZZ	7025-00-407-0743	389992	12344	CLUTCH ASSEMBLY,FRI.....	EA	2
82	10	XDDZZ		135560	12344	GEAR CLUSTER,BEVEL.....	EA	1
82	11	PADZZ	5310-00-701-9130	304282	12344	WASHER,SPRING TENSI.....	EA	1
82	12	PADZZ	5365-00-634-7444	5103-18MD	79136	RING,RETAINING.....	EA	1
82	13	XDDZZ		225377	12344	SHIM.....	EA	1
82	14	PADZZ	3020-00-489-0309	333920	12344	SHAFT,STRAIGHT.....	EA	1
82	15	PADZZ	3020-00-987-7682	135540	12344	GEAR CLUSTR,BEVEL.....	EA	1
82	16	PADZZ	3020-00-987-7683	138240	12344	GEAR CLUSTER,BEVEL.....	EA	1
82	11	XDDZZ		415440	12344	SETSCREW.....	EA	1
						GROUP 1201010502 MAGNETIC ACTUATOR ASSEMBLY,REVERSE L2		
82	18	PAHZZ	5950-00-052-2570	220535	12344	COIL,ELECTRICAL.....	EA	1
82	19	PAHZZ	7040-00-087-8439	318460	12344	ARMATURE,ESCAPEMENT.....	EA	1
82	20	PAHZZ	7040-00-087-8465	313740	12344	BRACKET,ESCAPEMENT.....	EA	1
82	21	XDHZZ		4157500	12344	SCREW,MACHINE.....	EA	6
82	22	PAHZZ	5305-00-601-9080	304370	12344	SCREW,TENSION ADJ.....	EA	1
82	23	XDHZZ		AN365C632	88044	NUT,SELF-LOCKING.....	EA	2
82	24	PAHZZ	5360-00-82-6808	356280	12344	SPRNG,TENSION.....	EA	2
82	25	PAHZZ	7040-00-087-8464	223760	12344	FRAME,COIL ASSEMBLY.....	EA	1
82	26	PAHZZ	3040-00-477-8279	378510	12344	LEVER,ESCAPEMNT.....	EA	2
82	27	XDHZZ	5310-00-595-6425	4176150	12344	WASHERFLAT.....	EA	2
82	28	PAHZZ	5365-00-971-6201	226374	12344	SHIM.....	EA	1

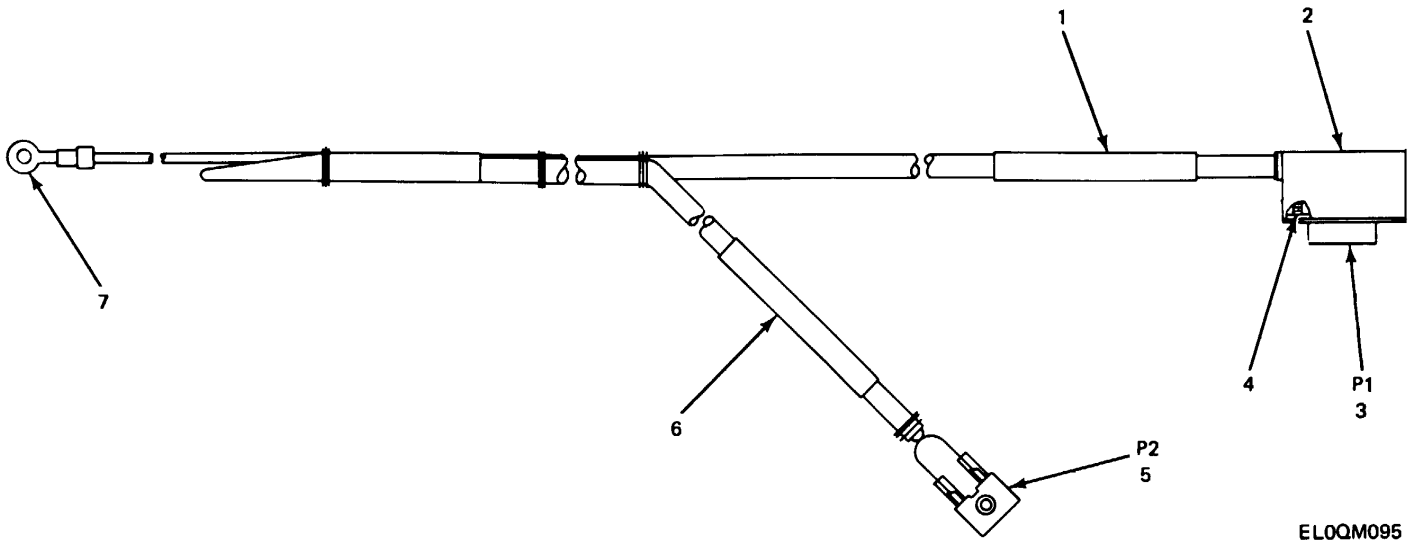
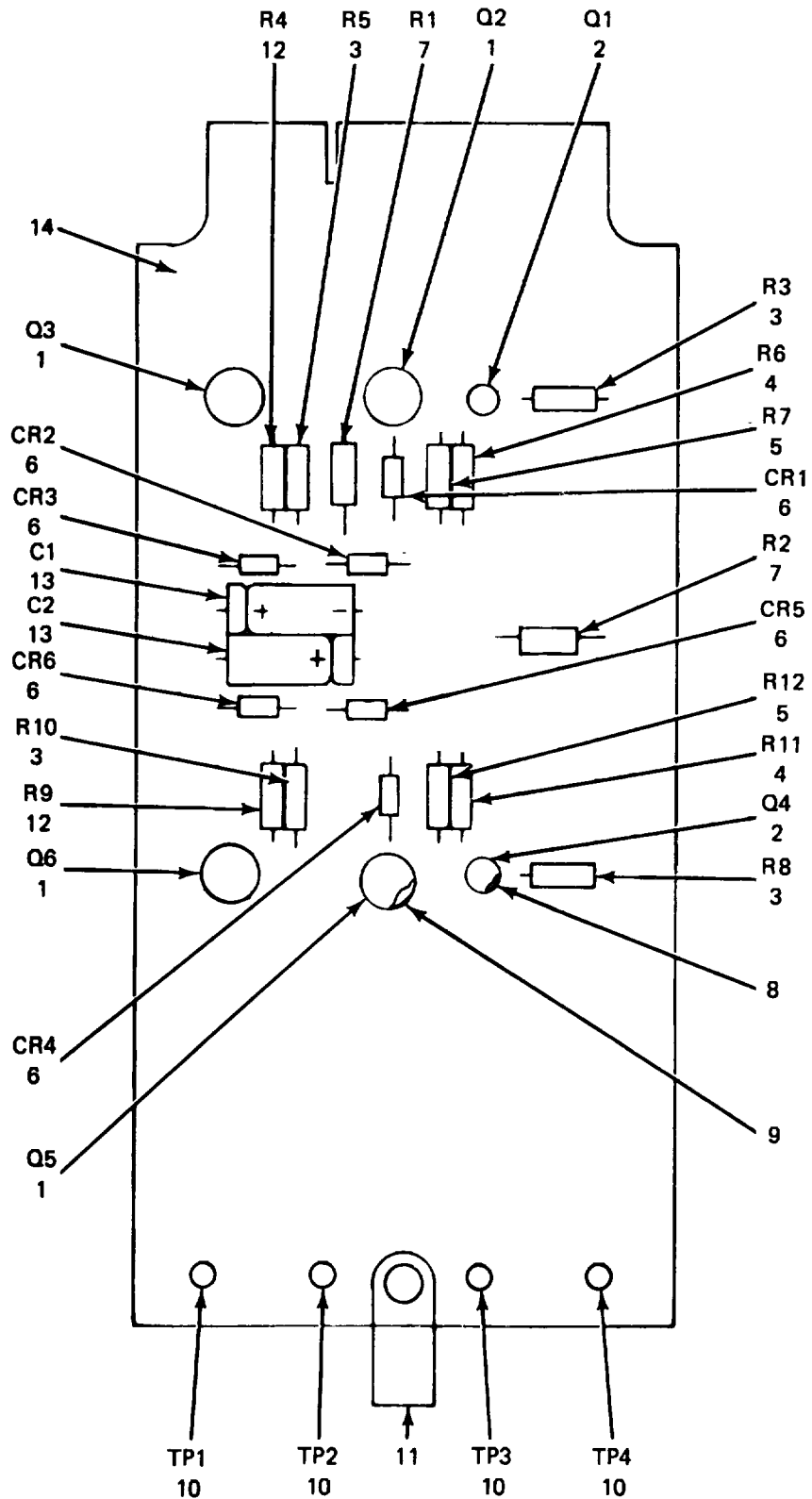

Figure 83. Cable Assembly (40639G1).

SECTION II

(1) ILLUSTRATION		(2)	(3)	(4)	(5)	(6) DESCRIPTION	(7)	(8)
(a) FIG NO.	(b) ITEM NO.	SMR CODE	NATIONAL STOCK NUMBER	PART NUMBER	FSCM	USABLE ON CODE	U/M	QTY INC IN UNIT
						GROUP 12010106 CABLE ASSEMBLY (40639G1)		
83	1	XDHZZ		56626-7	06809	MARKER,CABLE.....	EA	1
83	2	PAHZZ	5935-00-816-8713	DE90JS19977-5	71468	SHIELD,ELECTRICAL C.....	EA	1
83	3	PAHZZ	5935-00-710-1717	DE9P	71468	CONNECTOR.RECEPTACL.....	EA	1
83	4	PAHZZ	5305-00-068-5414	MS16995-11	96906	SCREW,CAP,SOCKET HE.....	EA	2
83	5	PAHZZ	5935-00-813-8579	JF2S	81312	CONNECTOR,RECEPTACL.....	EA	1
83	6	XDHZZ		56626-3	06809	MARKER,CABLE.....	EA	1
83	7	XDHZZ		RB863	02032	TERMINAL,LUG.....	EA	1



NOTE: PREFIX ALL REFERENCE DESIGNATIONS WITH A3A2A0

EL0QM096

Figure 84. Circuit Card Assembly A3A2A0.

SECTION II

TM 11-7440-222-40P/NAVELEX 0967-LP-324-0480/TO 31W4-2G-84

(1) ILLUSTRATION		(2)	(3)	(4)	(5)	(6) DESCRIPTION	(7)	(8)
(a) FIG NO.	(b) ITEM NO.	SMR CODE	NATIONAL STOCK NUMBER	PART NUMBER	FSCM	USABLE ON CODE	U/M	QTY INC IN UNIT
						GROUP 120102 CIRCUIT CARD ASSEMBLY A3A2A0		
84	1	PADZZ	5961-00-901-4862	2N3638	34148	TRANSISTOR.....	EA	4
84	2	PADZZ	5961-00-988-1911	2N797	80131	TRANSISTOR.....	EA	2
84	3	XDDZZ		C20-27ZG	16299	RESISTOR,FXD,FILM.....	EA	4
84	4	XDDZZ		C20-122G	88813	RESISTOR,FXD,FILM.....	EA	2
84	5	XDDZZ		CZ-91G	16295	RESISTOR,FXD,FILM.....	EA	2
84	6	PADZZ	5961-00-917-8504	SSD762	03508	SEMICONDUCTOR DEVIC	EA	2
84	7	PADZZ	5905-00-786-8306	RC20GF3R9J	81349	RESISTOR,FIXED,COMP	EA	2
84	8	PADZZ	5970-00-989-8333	A10042	07047	INSULATOR,DISK.....	EA	6
84	9	PADZZ	5999-00-068-1987	TP501	08289	MOUNTING PAD,ELECTR.....	EA	4
84	10	PADZZ	5940-00-990-1658	MS17122-6	96906	TERMINAL,STUD.....	EA	4
84	11	PADZZ	5340-00-969-6501	NPC7	81074	CLAMP,LOOP	EA	1
84	12	XDDZZ		C20-562G	16299	RESISTOR,FXD,FILM.....	EA	2
84	13	XDDZZ		40D106G102BB0	56289	CAPACITOR,ELCTLT	EA	2
84	14	XDDZZ		44403G1	06809	PRINTED CKT BOARD.....	EA	1

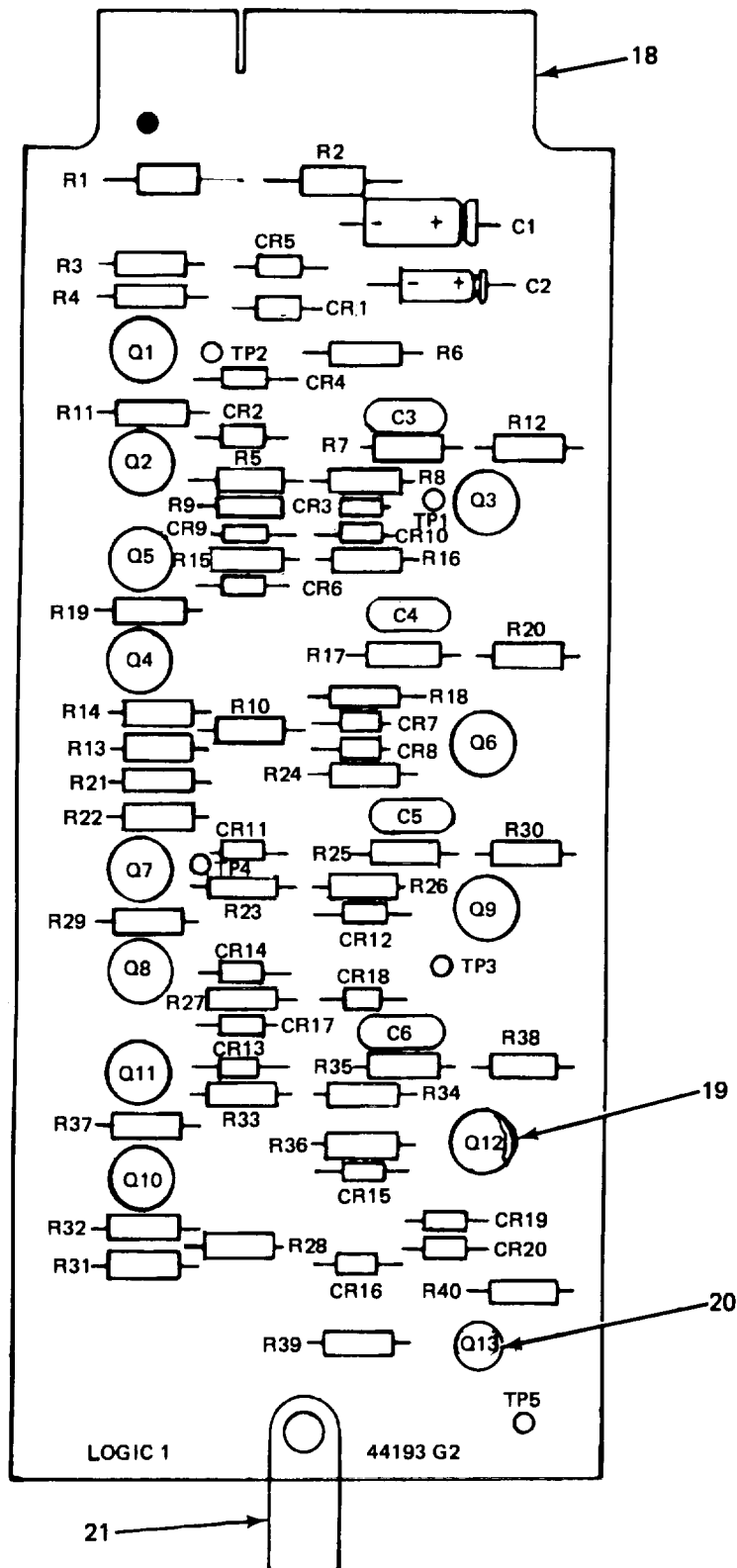

NOTE: PREFIX ALL REFERENCE DESIGNATIONS WITH A3A2A1 AND A3A2A2

ELOQM097

Figure 85. Circuit card Assembly A3A2A1 (Sheet 1 of 2).

REF. DES.	ITEM NO.	REF. DES.	ITEM NO.	REF. DES.	ITEM NO.	REF. DES.	ITEM NO.	REF. DES.	ITEM NO.	REF. DES.	ITEM NO.	REF. DES.	ITEM NO.
C1	1	CR7	4	CR19	5	Q11	6	R10	12	R22	11	R34	13
C2	2	CR8	5	CR20	5	Q12	7	R11	15	R23	12	R35	14
C3	3	CR9	4	Q1	6	Q13	8	R12	16	R24	13	R36	12
C4	3	CR10	5	Q2	6	R1	9	R13	10	R25	14	R37	15
C5	3	CR11	4	03	7	R2	9	R14	11	R26	12	R38	16
C6	3	CR12	4	04	6	R3	10	R15	12	R27	12	R39	14
CR1	4	CR13	4	Q5	6	R4	11	R16	13	R28	12	R40	12
CR2	4	CR14	4	06	7	R5	12	R17	14	R29	15	TP1	17
CR3	4	CR15	4	Q7	6	R6	13	R18	12	R30	16	TP2	17
CR4	4	CR16	5	Q8	6	R7	14	R19	15	R31	10	TP3	17
CR5	4	CR17	4	09	7	R8	12	R20	16	R32	11	TP4	17
CR6	4	CR18	5	Q10	6	R9	12	R21	10	R33	12	TP5	17

ELOQM098

Figure 85. Circuit card Assembly A3A2A1 (Sheet 2 of 2).

SECTION II

TM 11-7440-222-40P/NAVELEX 0967-LP-324-0480/TO 31W4-2G-84

(1) ILLUSTRATION		(2)	(3)	(4)	(5)	(6) DESCRIPTION	(7)	(8)
(a) FIG NO.	(b) ITEM NO.	SMR CODE	NATIONAL STOCK NUMBER	PART NUMBER	FSCM	USABLE ON CODE	U/M	QTY INC IN UNIT
						GROUP 120103 CIRCUIT CARD ASSEMBLY A3A2A1		
85	1	PADZZ	5910-00-827-1218	TE1204	56289	CAPACITOR, FIXED, ELE	EA	1
85	2	XDDZZ		NLW10-12	14655	CAPACITOR, ELCTLT	EA	1
85	3	PADZZ	5910-00-952-6432	CM06F561J03	81349	CAPACITOR, FXD, MICA.....	EA	4
85	4	PADZZ	5961-00-615-0095	1N276	81349	SEMICONDUCTOR DEVIC.....	EA	14
85	5	PADZZ	596-00-917-8504	SSD762	03508	SEMICONDUCTOR DEVIC.....	EA	6
85	6	PADZZ	5961-00-901-4862	2N3638	34148	TRANSISTOR.....	EA	8
85	7	PADZZ	5961-00-752-5229	2N404	81349	TRANSISTOR.....	EA	4
85	8	PADZZ	5961-00-902-7969	2N3012	80131	TRANSISTOR.....	EA	1
85	9	PADZZ	5905-00-786-8306	RC20GF3R9J	81349	RESISTOR, FIXED, COMP	EA	2
85	10	XDDZZ		C20-473G	07115	RESISTOR, FXD, FILM	EA	4
85	11	XDDZZ		C20-682G	07115	RESISTOR, FXD, FILM	EA	4
85	12	XDDZZ		C20-562G	16299	RESISTOR, FXD, FILM	EA	13
85	13	XDDZZ		C20-242G	07115	RESISTOR, FXD, FILM	EA	4
85	14	XDDZZ		C20-222G	07115	RESISTOR, FXD, FILM	EA	5
85	15	PADZZ	5905-00-904-7081	C20-102G	16299	RESISTOR, FXD, FILM	EA	4
85	16	XDDZZ		C20-153G	07115	RESISTOR, FXD, FILM	EA	4
85	17	PADZZ	5940-00-990-1658	MS17122-6	96906	TERNINAL, STUD	EA	5
85	18	XDDZZ		44293G1	06809	PRINTED CKT BOARD	EA	1
85	19	PADZZ	5999-00-068-1987	TP501	08289	MOUNTING PAD, ELECTR.....	EA	12
85	20	PADZZ	5970-00-989-8333	A10042	07047	INSULATOR, DISK.....	EA	1
85	21	PADZZ	5340-00-969-6501	NPC7	81074	CLAMP, LOOP	EA	1

219/(220 blank)

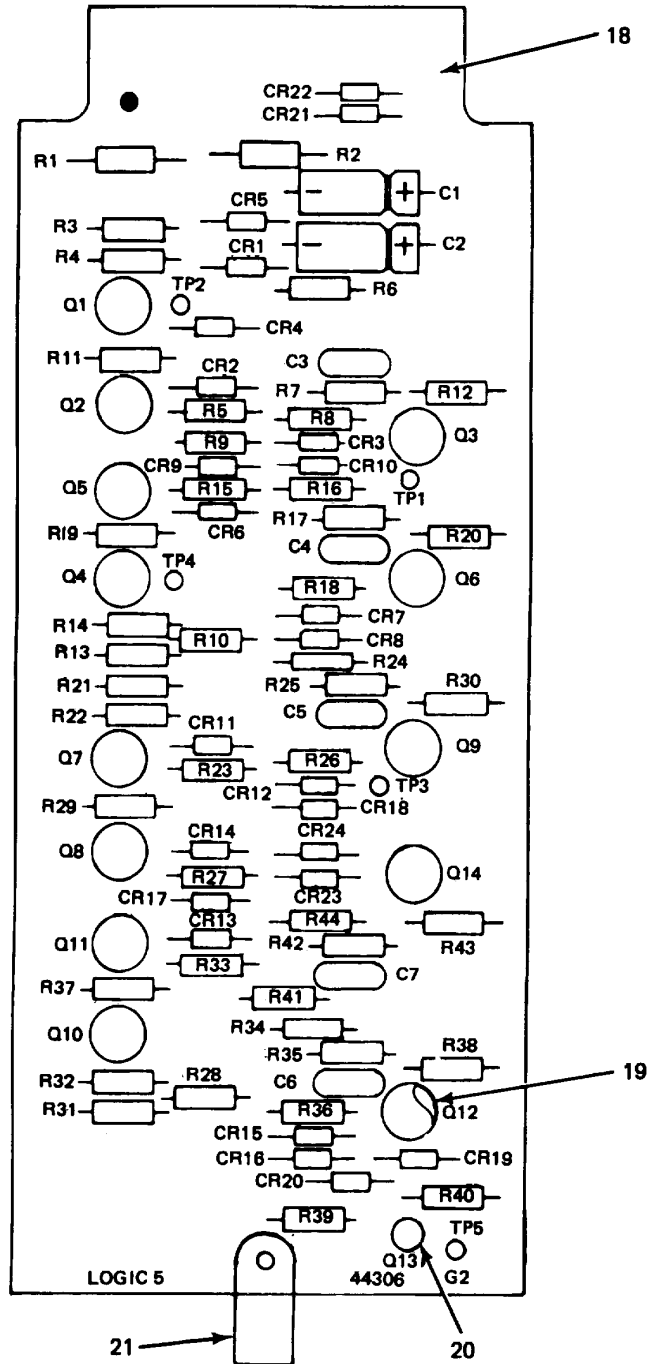

NOTE: PREFIX ALL REFERENCE DESIGNATIONS WITH A3A2A3

ELOQM099

Figure 86 Circuit Card Assembly A3A2A3 (Sheet 1 of 2).

REF. DES.	ITEM NO.	REF. DES.	ITEM NO.	REF. DES.	ITEM NO.	REF. DES.	ITEM NO.	REF. DES.	ITEM NO.	REF. DES.	ITEM NO.	REF. DES.	ITEM NO.
C1	1	CR8	5	CR22	4	Q12	7	R12	16	R26	12	R40	12
C2	2	CR9	4	CR23	4	Q13	8	R13	10	R27	12	R41	13
C3	3	CR10	4	CR24	4	Q14	7	R14	11	R28	12	R42	14
C4	3	CR11	4	Q1	6	R1	9	R15	12	R29	15	R43	16
C6	3	CR12	4	Q2	6	R2	9	R16	14	R30	16	R44	12
C6	3	CR13	4	Q3	7	R3	10	R17	13	R31	10	TP1	17
C7	3	CR14	4	Q4	6	R4	11	R18	12	R32	11	TP2	17
CR1	4	CR15	4	Q5	6	R5	12	R19	15	R33	12	TP3	17
CR2	4	CR16	5	Q6	7	R6	13	R20	16	R34	13	TP4	17
CR3	5	CR17	4	Q7	6	R7	14	R21	10	R35	14	TP5	17
CR4	4	CR18	5	Q8	6	R8	12	R22	11	R36	12		
CR5	4	CR19	5	Q9	7	R9	12	R23	12	R37	15		
CR6	4	CR20	5	Q10	6	R10	12	R24	13	R38	16		
CR7	4	CR21	4	Q11	6	R11	15	R25	14	R39	14		

EL0QM100

Figure 86. Circuit Card Assembly A3A2A3 (Sheet 2 of 2).

SECTION II

TM 11-7440-222-40P/NAVELEX 0967-LP-324-0480/TO 31W4-2G-84

(1) ILLUSTRATION		(2)	(3)	(4)	(5)	(6)	(7)	(8)
(a) FIG NO.	(b) ITEM NO.	SMR CODE	NATIONAL STOCK NUMBER	PART NUMBER	FSCM	DESCRIPTION USABLE ON CODE	U/M	QTY INC IN UNIT
						GROUP 120105 CIRCUIT CARD ASSEMBLY A3A2A3		
86	1	XDDZZ		40D106G025BB0	56289	CAPACITOR, FIXED, ELE	EA	1
86	2	XDDZZ		40D106G012BB0	56289	CAPACITOR, ELCTLT	EA	1
86	3	PADZZ	5910-00-952-6432	CM06F561J03	81349	CAPACITOR, FXD, MICA.....	EA	5
86	4	PADZZ	5961-00-615-0095	1N276	81349	SEMICONDUCTOR DEVIC.....	EA	18
86	5	PADZZ	5961-00-917-8504	SSD762	03508	SEMICONDUCTOR DEVIC.....	EA	6
86	6	PADZZ	5961-00-901-4862	2N3638	34148	TRANSISTOR.....	EA	8
86	7	PADZZ	5961-00-752-5229	2N404	81349	TRANSISTOR.....	EA	5
86	8	PADZZ	5961-00-902-7969	2N3012	80131	TRANSISTOR.....	EA	1
86	9	PADZZ	5905-00-786-8306	RC20GF3R9J	81349	RESISTOR, EIXED, COMP.....	EA	2
86	10	XDDZZ		C20-473G	07115	RESISTOR, FXD, FILM.....	EA	4
86	11	XDDZZ		C20-682G	07115	RESISTOR, FXD, FILM.....	EA	4
86	12	XDDZZ		C20-562G	16299	RESISTOR, FXD, FILM.....	EA	14
86	13	XDDZZ		C20-242G	07115	RESISTOR, FXD, FILM.....	EA	5
86	14	XDDZZ		C20-222G	07115'	RESISTOR, FXD, FILM.....	EA	6
86	15	PADZZ	5905-00-904-7081	C20-102G	16299	RESISTOR, FIXED, FILM.....	EA	4
86	16	XDDZZ	C20-153G		07115	RESISTOR, FXD, FILM.....	EA	5
86	17	PADZZ	5940-00-990-1658	MS17122-6	96906	TERMINAL, STUD.....	EA	5
86	18	XDDZZ		44406	06809	PRINTED WIRING BD	EA	1
86	19	XDDZZ	5961-00-909-4138	10162DAP	07047	MOUNTING PAD, TRANSI.....	EA	13
86	20	PADZZ	5970-00-989-8333	A10042	07047	INSULATOR, DISK.....	EA	1
86	21	PADZZ	5340-00-969-6501	NPC7	81074	CLAMP, LOOP	EA	1

223/(224 blank)

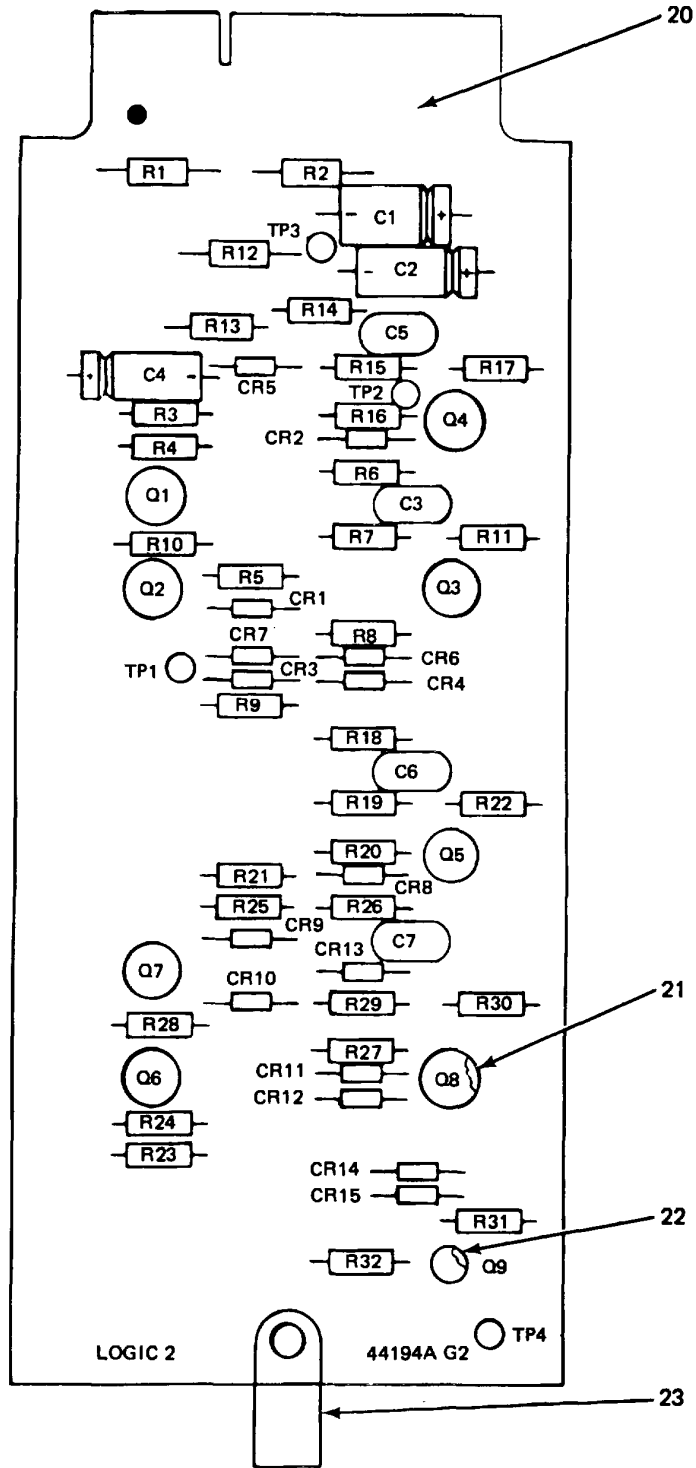

NOTE: PREFIX ALL REFERENCE DESIGNATIONS WITH A3A2A4

ELQOM101

Figure 87. Circuit Card Assembly A3A2A4 (Sheet 1 of 2)

REF. DES.	ITEM NO.	REF. DES.	ITEM NO.	REF. DES.	ITEM NO.	REF. DES.	ITEM NO.	REF. DES.	ITEM NO.	REF. DES.	ITEM NO.	REF. DES.	ITEM NO.
C1	1	CR4	5	CR14	6	Q9	9	R10	17	R20	14	R30	18
C2	2	CR5	5	CR15	6	R1	10	R11	18	R21	14	R31	14
C3	3	CR6	5	Q1	7	R2	11	R12	10	R22	18	R32	16
C4	4	CR7	5	Q2	7	R3	12	R13	16	R23	12	TP1	19
C5	3	CR8	5	Q3	8	R4	13	R14	15	R24	13	TP2	19
C6	3	CR9	5	Q4	8	R5	14	R15	16	R25	14	TP3	19
C7	3	CR10	5	Q5	8	R6	15	R16	14	R26	15	TP4	19
CR1	5	CR11	5	Q6	7	R7	16	R17	18	R27	14		
CR2	5	CR12	6	Q7	7	R8	14	R18	15	R28	17		
CR3	5	CR13	6	Q8	8	R9	14	R19	16	R29	16		

ELOQM102

Figure 87. Circuit Card Assembly A3A2A4 (Sheet 2 of 2)

SECTION II

TM 11-7440-222-40P/NAVELEX 0967-LP-324-0480/TO 31W4-2G-84

(1) ILLUSTRATION		(2)	(3)	(4)	(5)	(6)	(7)	(8)
(a) FIG NO.	(b) ITEM NO.	SMR CODE	NATIONAL STOCK NUMBER	PART NUMBER	FSCM	DESCRIPTION USABLE ON CODE	U/M	QTY INC IN UNIT
						GROUP 120106 CIRCUIT CARD ASSEMBLY A3A2A4		
87	1	PADZZ	5910-00-827-1218	TE1204	56289	CAPACITOR, FIXED, ELE	EA	1
87	2	XDDZZ		NLW10-12	14655	CAPACITOR, ELCTLT	EA	1
87	3	PADZZ	5910-00-952-6432	CM06F561J03	81349	CAPACITOR, FXD, MICA	EA	4
87	4	PADZZ	5910-00-864-8330	NLW1-12	09023	CAPACITOR, FIXED, EL	EA	1
87	5	PADZZ	5961-00-615-0095	1N276	81349	SEMICONDUCTOR DEVIC	EA	11
87	6	PADZZ	5961-00-917-8504	SSD762	03508	SEMICONDUCTOR DEVIC	EA	4
87	7	PADZZ	5961-00-901-4862	2N3638	34148	TRANSISTOR	EA	4
87	8	PADZZ	5961-00-752-5229	2N404	81349	TRANSISTOR	EA	4
87	9	PADZZ	5961-00-902-7969	2N3012	80131	TRANSISTOR	EA	1
87	10	PADZZ	5905-00-190-8883	RC20GF100J	81349	RESISTOR, FIXED, COMP	EA	2
87	11	XDDZZ		EB2R75	01121	RESISTOR, FXD, CMPSN	EA	1
87	12	XDDZZ		C20-473G	07115	RESISTOR, FXD, FILM	EA	2
87	13	XDDZZ		C20-682G	07115	RESISTOR, FXD, FILM	EA	2
87	14	XDDZZ		C20-562G	16299	RESISTOR, FXD, FILM	EA	9
87	15	XDDZZ		C20-242G	07115	RESISTOR, FXD, FILM	EA	4
87	16	XDDZZ		C20-222G	07115	RESISTOR, FXD, FILM	EA	6
87	17	PADZZ	5905-00-904-7081	C20-102G	16299	RESISTOR, FXD, FILM	EA	2
87	18	XDDZZ		C20-153G	07115	RESISTOR, FXD, FILM	EA	4
87	19	PADZZ	5940-00-990-1658	MS17122-6	96906	TERMINAL, STUD	EA	4
87	20	XDDZZ		44294	06809	PRINTED CKT BOARD	EA	1
87	21	PADZZ	5999-00-068-1987	TP501	08289	MOUNTING PAD, ELECTR	EA	8
87	22	PADZZ	5970-00-989-8333	A10042	07047	INSULATOR, DISK	EA	1
87	23	PADZZ	5340-00-969-6501	NPC7	81074	CLAMP, LOOP	EA	1

227/(228 blank)

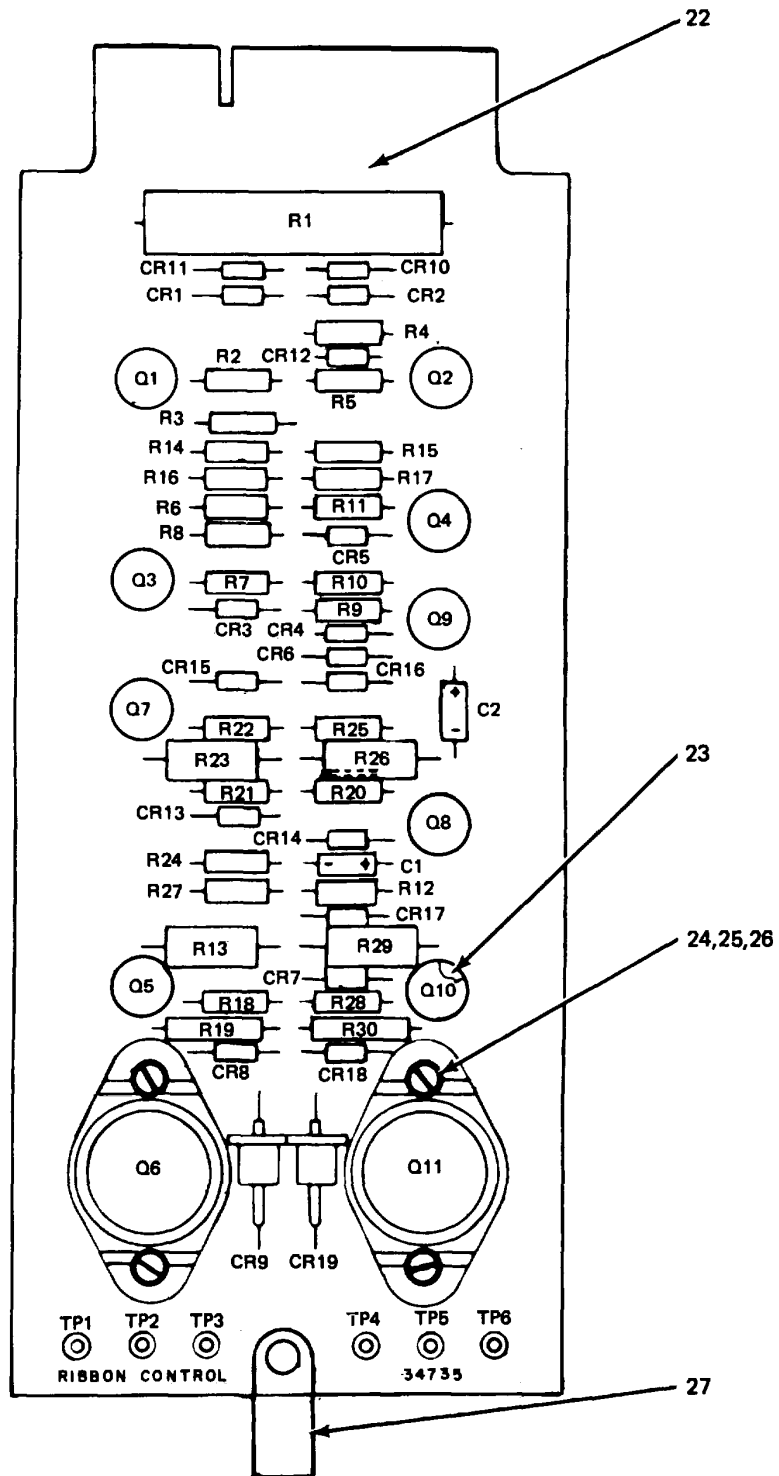

NOTE: PREFIX ALL REFERENCE DESIGNATIONS WITH A3A2B0

EL00M103

Figure 88. Circuit Card Assembly A3A2B0 (Sheet 1 of 2)

REF. DES.	ITEM NO.	REF. DES.	ITEM NO.	REF. DES.	ITEM NO.	REF. DES.	ITEM NO.	REF. DES.	ITEM NO.	REF. DES.	ITEM NO.	REF. DES.	ITEM NO.
C1	1	CR9	5	CR19	5	Q10	6	R9	11	R19	17	R29	14
C2	1	CR10	2	Q1	6	Q11	7	R10	10	R20	10	R30	17
CR1	2	CR11	2	Q2	6	R1	9	R11	12	R21	11	TP1	21
CR2	2	CR12	2	Q3	6	R2	10	R12	13	R22	15	TP2	21
CR3	2	CR13	2	Q4	6	R3	11	R13	14	R23	18	TP3	21
CR4	2	CR14	2	Q5	6	R4	11	R14	15	R24	19	TP4	21
CR5	2	CR15	2	Q6	7	R5	10	R15	15	R25	14	TP5	21
CR6	2	CR16	2	Q7	6	R6	12	R16	15	R26	20	TP6	21
CR7	3	CR17	3	Q8	8	R7	10	R17	15	R27	13		
CR8	4	CR18	4	Q9	6	R8	11	R18	16	R28	16		

ELOQM104

Figure 88 Circuit Card Assembly A3A2b0 (Sheet 2 of 2).

SECTION II

TM 11-7440-222-40P/NAVELEX 0967-LP-324-0480/TO 31W4-2G-84

(1) ILLUSTRATION		(2)	(3)	(4)	(5)	(6)	(7)	(8)
(a) FIG NO.	(b) ITEM NO.	SMR CODE	NATIONAL STOCK NUMBER	PART NUMBER	FSCM	DESCRIPTION USABLE ON CODE	U/M	QTY INC IN UNIT
						GROUP 120107 CIRCUIT CARD ASSEMBLY A3A2B0		
88	1	PADZZ	5910-00-787-2109	CS13BF105K	81349	CAPACITOR, FIXED, ELE	EA	2
88	2	PADZZ	5961-00-615-0095	1N276	81349	SEMICONDUCTOR DEVIC.....	EA	13
88	3	PADZZ	5961-00-883-6064	JAN1N749A	81349	SEMICONDUCTOR, DIODE	EA	2
88	4	PADZZ	5961-00-917-8504	SSD762	03508	SEMICONDUCTOR DEVIC.....	EA	2
88	5	PADZZ	5961-00-577-6214	1N37	81349	SEMICONDUCTOR DEVIC.....	EA	2
88	6	PADZZ	5961-00-752-5229	2N404	81349	TRANSISTOR.....	EA	8
88	7	PADZZ	5961-00-925-3749	2N2612	80131	TRANSISTOR.....	EA	2
88	8	PADZZ	5961-00-808-8398	2N91	81349	TRANSISTOR.....	EA	1
88	9	PADZZ	5905-00-975-1131	RW68V750	81349	RESISTOR, FIXED, WIRE	EA	1
88	10	PADZZ	5905-00-985-5466	RN60D6811F	81349	RESISTOR, FIXED, FILM.....	EA	5
88	11	PADZZ	5905-00-984-1465	RN60D5621F	81349	RESISTOR, FIXED, FILM.....	EA	5
88	12	PADZZ	5905-00-983-6914	RN60D1002F	81349	RESISTOR, FIXED, FILM.....	EA	2
88	13	PADZZ	5905-00-988-2306	RN60D4641F	81349	RESISTOR, FIXED, FILM.....	EA	2
88	14	PADZZ	5905-00-051-0752	RL32S560G	81349	RESISTOR, FIXED, FILM.....	EA	3
88	15	XDDZZ		RN60D121F	81349	RESISTOR, FXD, FILM	EA	5
88	16	PADZZ	5905-00-069-3917	RN60D8251F	81349	RESISTOR, FIXED, FILM.....	EA	2
88	17	PADZZ	5905-00-062-5037	RN65D5620F	81349	RESISTOR, FIXED, FILM.....	EA	2
88	18	PADZZ	5905-00-775-4631	RL32S102G	81349	RESISTOR, FIXED, FILM.....	EA	1
88	19	PADZZ	5905-00-957-0642	RN60D2213F	81349	RESISTOR, FIXED, FILM.....	EA	1
88	20	PADZZ	5905-00-985-4889	RN60D8250F	81349	RESISTOR, FIXED, FILM.....	EA	1
88	21	PADZZ	5940-00-990-1658	MS17122-6	96906	TERMINAL, STUD.....	EA	6
88	22	XDDZZ		34835	06809	PRINTED CKT BOARD	EA	1
88	23	PADZZ	5999-00-068-1987	TP501	08289	MOUNTING PAD, ELECTR.....	EA	9
88	24	PADZZ	5305-00-068-5414	MS16995-11	96906	SCREW, CAP, SOCKET HE	EA	2
88	25	PADZZ	5310-00-550-3715	1704-00	78189	WASHER, LOCK	EA	2
88	26	PADZZ	4920-00-874-9758	1300-9	71279	SPACER.....	EA	2
88	27	PADZZ	5340-00-969-6501	NPC7	81074	CLAMP, LOOP	EA	1

231/(232 blank)

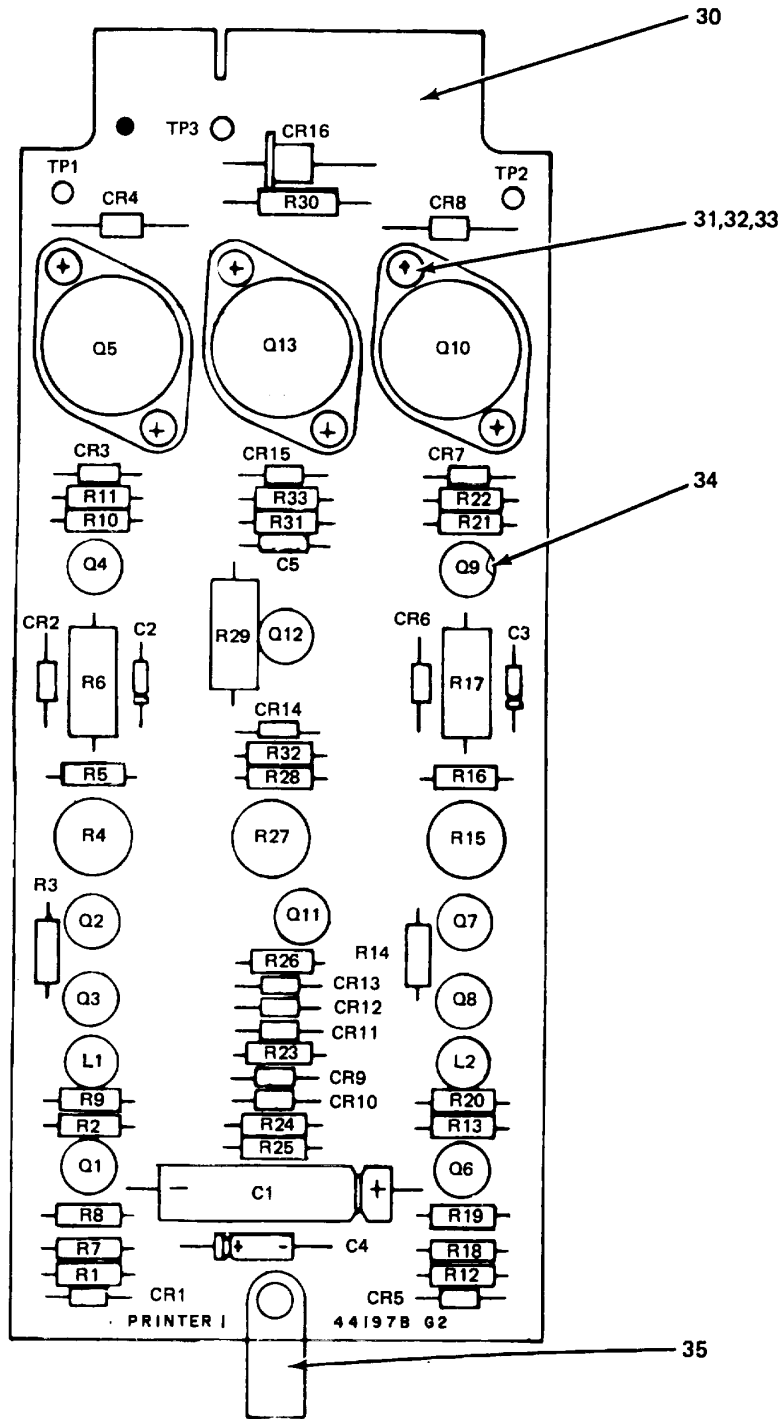

NOTE: PREFIX ALL REFERENCE DESIGNATIONS WITH A3A2B1

ELOQM105

Figure 89. Circuit Card Assembly A3A2B1 (Sheet 1 of 2).

REF. DES.	ITEM NO.	REF. DES.	ITEM NO.	REF. DES.	ITEM NO.	REF. DES.	ITEM NO.	REF. DES.	ITEM NO.	REF. DES.	ITEM NO.	REF. DES.	ITEM NO.
C1	1	CR7	7	L2	11	Q11	15	R9	23	R20	23	R31	23
C2	2	CR8	8	Q1	12	Q12	12	R10	23	R21	23	R32	28
C3	2	CR9	9	Q2	12	Q13	14	R11	24	R22	24	R33	24
C4	3	CR10	5	Q3	13	R1	16	R12	16	R23	17	TP1	29
C5	4	CR11	5	Q4	12	R2	17	R13	17	R24	25	TP2	29
CR1	5	CR12	5	Q5	14	R3	17	R14	17	R25	21	TP3	29
CR2	6	CR13	5	Q6	12	R4	18	R15	18	R26	17		
CR3	7	CR14	9	Q7	12	R5	19	R16	19	R27	18		
CR4	8	CR15	7	Q8	13	R6	20	R17	20	R28	26		
CR5	5	CR16	10	Q9	12	R7	21	R18	21	R29	20		
CR6	6	L1	11	Q10	14	R8	22	R19	22	R30	27		

EL0QM106

Figure 89. Circuit Card Assembly A3A2B1 (Sheet 2 of 2).

SECTION II

TM 11-7440-222-40P/NAVELEX 0967-LP-324-0480/TO 31W4-2G-84

(1) ILLUSTRATION		(2)	(3)	(4)	(5)	(6)	(7)	(8)
(a) FIG NO.	(b) ITEM NO.	SMR CODE	NATIONAL STOCK NUMBER	PART NUMBER	FSCM	DESCRIPTION USABLE ON CODE	U/M	QTY INC IN UNIT
						GROUP 120108 CIRCUIT CARD ASSEMBLY A3A2B1		
89	1	PADZZ	5910-00-009-4597	NLW100-25	14655	CAPACITOR, FIXED, ELE	EA	1
89	2	PADZZ	5910-00-812-2751	150D564X9035A2	56289	CAPACITOR, ELCTLT	EA	2
89	3	PADZZ	5910-00-864-8330	NLW1-12	09023	CAPACITOR, FIXED, EL	EA	1
89	4	PADZZ	5910-00-838-1409	150D274X9035A2	56289	CAPACITOR, FIXED, ELE	EA	1
89	5	PADZZ	5961-00-615-0095	1N276	81349	SEMICONDUCTOR DEVIC	EA	6
89	6	PADZZ	5961-00-883-6064	JAN1N749A	81349	SEMICONDUCTOR DEVIC	EA	2
89	7	PADZZ	5961-00-917-8504	SSD762	03508	SEMICONDUCTOR DEVIC	EA	3
89	8	PADZZ	5961-00-929-4947	VR56A	51589	SEMICONDUCTOR DEVIC	EA	2
89	9	PADZZ	5961-00-972-0046	DHD572	03508	SEMICONDUCTOR DEVIC	EA	2
89	10	PADZZ	5961-00-577-6214	1N537	81349	SEMICONDUCTOR DEVIC	EA	1
89	11	PADZZ	5950-00-925-8958	J302-6800	76487	INDUCTOR STANDARD	EA	2
89	12	PADZZ	5961-00-404-5592	GTR502	03508	TRANSISTOR	EA	7
89	13	PADZZ	5961-00-882-4566	2N1605	80131	TRANSISTOR	EA	2
89	14	PADZZ	5961-00-925-3749	2N2612	80131	TRANSISTOR	EA	3
89	15	PADZZ	5961-00-752-5229	2N404	81349	TRANSISTOR	EA	1
89	16	PADZZ	5905-00-904-7083	C20-103G	16299	RESISTOR, FXD, FILM	EA	2
89	17	XDDZZ		C20-152G	07115	RESISTOR, FXD, FILM	EA	6
89	18	XDDZZ		100-5K	75042	RESISTOR, VARIABLE, W	EA	3
89	19	XDDZZ		C20-822G	07115	RESISTOR, FXD, FILM	EA	2
89	20	PADZZ	5905-00-769-4147	RL42S101G	81349	RESISTOR, FIXED, FILM	EA	3
89	21	XDDZZ		C20-222G	07115	RESISTOR, FXD, FILM	EA	3
89	22	XDDZZ		C20-153G	07115	RESISTOR, FXD, FILM	EA	2
89	23	XDDZZ		C20-302G	07115	RESISTOR, FXD, FILM	EA	5
89	24	XDDZZ		C20-301G	07115	RESISTOR, FXD, FILM	EA	3
89	25	PADZZ	5905-00-190-8883	RC20GF100J	81349	RESISTOR, FIXED, COMP	EA	1
89	26	XDDZZ		C20-562G	16299	RESISTOR, FXD, FILM	EA	1
89	27	PADZZ	5905-00-951-6735	RW69V151	81349	RESISTOR, FIXED, WIRE	EA	1
89	28	PADZZ	5905-00-940-2751	RL20S561G	81349	RESISTOR, FIXED, FILM	EA	1
89	29	PADZZ	5940-00-990-1658	MS17122-6	96906	TERMINAL, STUD	EA	3
89	30	XDDZZ		44297	06809	PRINTED CIRCUIT BD	EA	1
89	31	PADZZ	5305-00-068-5414	MS16995-11	96906	SCREW, CAP, SOCKET HE	EA	3
89	32	PADZZ	5310-00-550-3715	1704-00	78189	WASHER, LOCK	EA	3
89	33	PADZZ	4920-00-874-9758	1300-9	71279	SPACER	EA	3
89	34	PADZZ	5999-00-068-1987	TP501	08289	MOUNTING PAD, ELECTR	EA	4
89	35	PADZZ	5340-00-969-6501	NPC7	81074	CLAMP, LOOP	EA	1

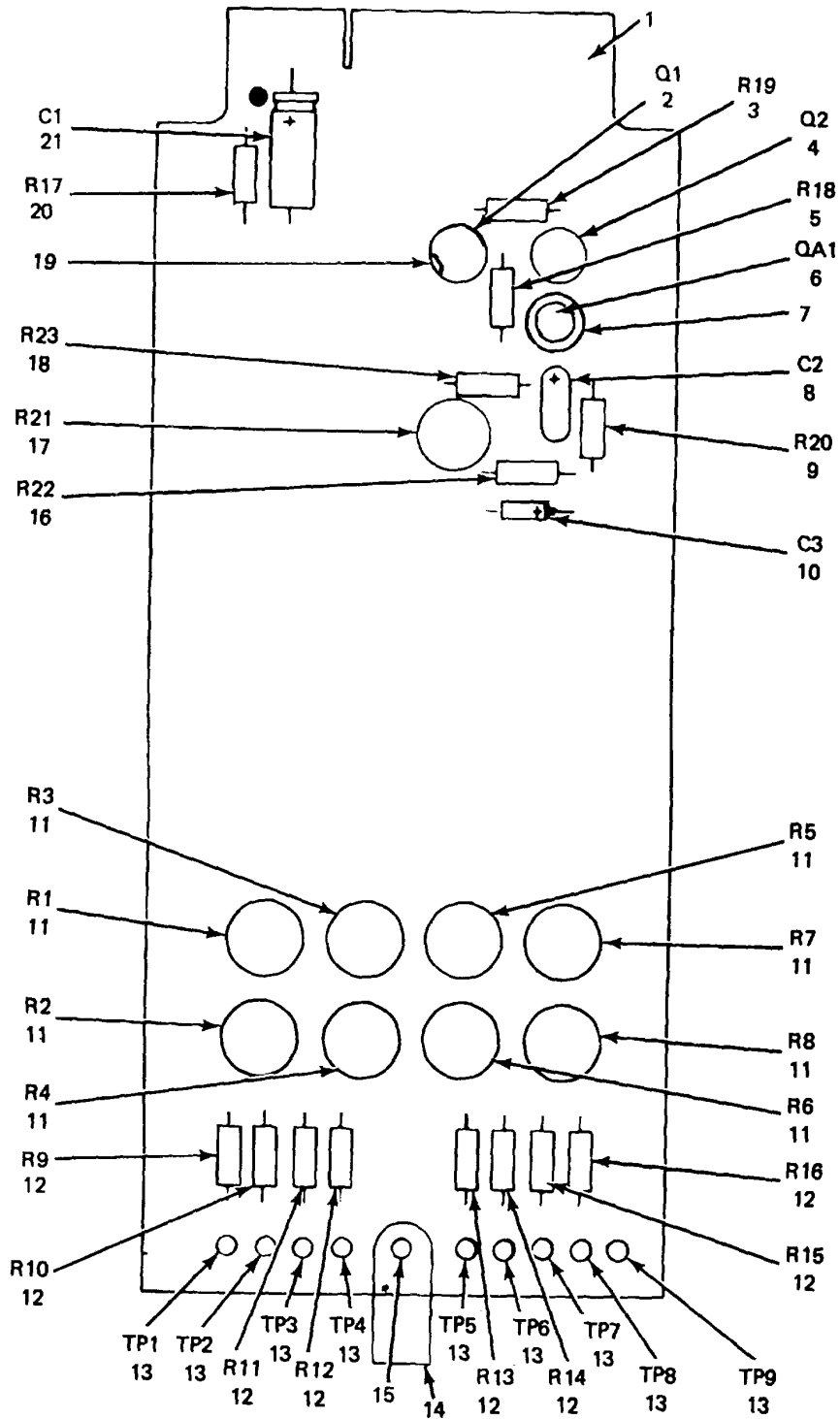

NOTE: PREFIX ALL REFERENCE DESIGNATIONS WITH A3A2B2

EL0QM107

Figure 90. Electrical Component Assembly A3A2B2.

SECTION II

TM 11-7440-222-40P/NAVELEX 0967-LP-324-0480/TO 31W4-2G-84

(1) ILLUSTRATION		(2)	(3)	(4)	(5)	(6) DESCRIPTION	(7)	(8)
(a) FIG NO.	(b) ITEM NO.	SMR CODE	NATIONAL STOCK NUMBER	PART NUMBER	FSCM	USABLE ON CODE	U/M	QTY INC IN UNIT
						GROUP 120109 ELECTRICAL COMPONENT ASSEMBLY A3A2B2		
90	1	XDDZZ		44552	06809	PRINTED CIRCUIT BD	EA	1
90	2	PADZZ	5961-00-929-2561	2N3642	80131	TRANSISTOR.....	EA	1
90	3	PADZZ	5905-00-887-4738	RL20S472G	81349	RESISTOR, FIXED, FILM.....	EA	1
90	4	PADZZ	5961-00-103-3981	2N3644	80131	TRANSISTOR.....	EA	1
90	5	PADZZ	5905-00-900-2051	RL20S102G	81349	RESISTOR, FIXED, FILM.....	EA	1
90	6	PADZZ	5962-00-127-8116	LM300	27014	MICROCIRCUIT, LINEAR	EA	1
90	7	PADZZ	5935-00-840-7175	8058-1G49	91506	SOCKET, PLUG-IN ELEC	EA	1
90	8	PADZZ	5910-0-649-2912	DM15-470J	72136	CAPACITOR, FIXED, MIC.....	EA	1
90	9	PADZZ	5905-0-926-8706	RL20S101G	81349	RESISTOR, FIXED, FILM.....	EA	1
90	10	PADZZ	5910-00-821-4037	150D824X9035A2	56289	CAPACITOR, FIXED, ELE	EA	1
90	11	PADZZ	5905-00-105-1964	100-50K	75042	RESISTOR, VARIABLE, W	EA	8
90	12	PADZZ	5905-00-727-9777	RL20S332G	81349	RESISTOR, FIXED, FILM.....	EA	8
90	13	PADZZ	5940-00-990-1658	MS17122-6	96906	TERMINAL, STUD.....	EA	9
90	14	PADZZ	5340-00-969-6501	NPC7	81074	CLAMP, LOOP	EA	1
90	15	XDDZZ		3293-3-16	61007	RIVET, SEMITUBULAR.....	EA	1
90	16	PADZZ	5905-00-403-3062	RLR20C432GR	81349	RESISTOR, FXD, FILM	EA	1
90	17	PADZZ	5340-00-003-9207	HP-4N	09922	RESISTOR, VAR, W	EA	1
90	18	PADZZ	5905-00-727-9747	RL20S431G	81349	RESISTOR, FIXED, FILM.....	EA	1
90	19	PADZZ	5999-00-068-1987	TP501	08289	MOUNTING PAD, ELECTR.....	EA	2
90	20	XDDZZ		C20-100J	88813	RESISTOR, FXD, FILM	EA	1
90	21	PADZZ	5910-00-688-6881	NLW10-25	14655	CAPACITOR, FIXED, ELE	EA	1

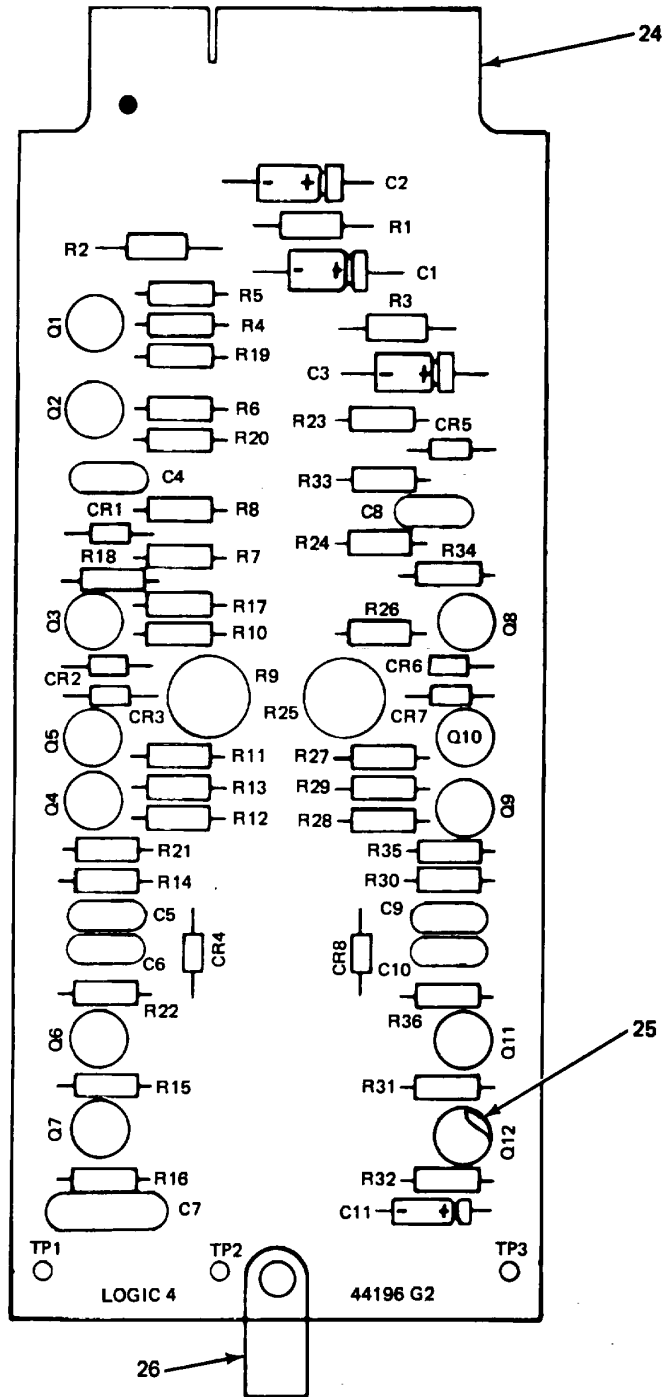

NOTE: PREFIX ALL REFERENCE DESIGNATIONS WITH A3A2B3

ELOQM108

Figure 91. Circuit Card Assembly A3A2B3 (Sheet 1 of 2).

REF. DES.	ITEM NO.	REF. DES.	ITEM NO.	REF. DES.	ITEM NO.	REF. DES.	ITEM NO.	REF. DES.	ITEM NO.	REF. DES.	ITEM NO.	REF. DES.	ITEM NO.
C1	1	C11	5	Q2	8	Q12	9	R10	15	R20	15	R30	18
C2	2	CR1	6	Q3	9	R1	11	R11	15	R21	22	R31	19
C3	1	CR2	6	Q4	10	R2	12	R12	15	R22	22	R32	20
C4	3	CR3	6	Q5	10	R3	11	R13	15	R23	15	R33	15
C5	3	CR4	7	Q6	10	R4	13	R14	18	R24	16	R34	21
C6	3	CR5	7	Q7	9	R5	14	R15	19	R25	17	R35	22
C7	4	CR6	6	Q8	9	R6	15	R16	20	R26	15	R36	22
C8	3	CR7	6	Q9	10	R7	15	R17	15	R27	15	TP1	23
C9	3	CR8	6	Q10	10	R8	16	R18	21	R28	15	TP2	23
C10	3	Q1	8	Q11	10	R9	17	R19	20	R29	15	TP3	23

EL0QM109

Figure 91. Circuit Card Assembly A3A2B3 (Sheet 2 of 2).

SECTION II

TM 11-7440-222-40P/NAVELEX 0967-LP-324-0480/TO 31W4-2G-84

(1) ILLUSTRATION		(2)	(3)	(4)	(5)	(6)	(7)	(8)
(a) FIG NO.	(b) ITEM NO.	SMR CODE	NATIONAL STOCK NUMBER	PART NUMBER	FSCM	DESCRIPTION USABLE ON CODE	U/M	QTY INC IN UNIT
						GROUP 120110 CIRCUIT CARD ASSEMBLY A3A283		
91	1	XDDZZ		NLW10-12	14655	CAPACITOR,ELCTLT	EA	2
91	2	PADZZ	5910-00-827-1218	TE1204	56289	CAPACITOR,FIXED,ELE	EA	1
91	3	PADZZ	5910-00-952-6432	CM06F561J03	81349	CAPACITOR,FXD,MICA.....	EA	6
91	4	PADZZ	5910-00-064-0882	IDP2-473	72136	CAPACITOR,FIXED,PLA	EA	1
91	5	XDDZZ		CS138D106K	81349	CAPACITOR,ELCTLT	EA	1
91	6	PADZZ	5961-00-615-0095	1N276	81349	SEMICONDUCTOR DEVIC.....	EA	6
91	7	PADZZ	5961-00-836-6667	JAN1N816	80131	SEMICONDUCTOR,DIODE	EA	2
91	8	PADZZ	5961-00-901-4862	2N3638	34148	TRANSISTOR.....	EA	2
91	9	PADZZ	5961-00-882-4566	2N1605	80131	TRANSISTOR.....	EA	4
91	10	PADZZ	5961-00-752-5229	2N404	81349	TRANSISTOR.....	EA	6
91	11	XDDZZ		EB2R75	01121	RESISTOR,FXD,CMPSN	EA	2
91	12	PADZZ	5905-00-190-8883	RC20GF100J	81349	RESISTOR,FIXED,COMP	EA	1
91	13	XDDZZ		C20-473G	07115	RESISTOR,FXD,FILM.....	EA	1
91	14	XDDZZ		C20-682G	07115	RESISTOR,FXD,FILM.....	EA	1
91	15	XDDZZ		C20-302G	07115	RESISTOR,FXD,FILM.....	EA	14
91	16	XDDZZ		C20-243G	07115	RESISTOR,FXD,FILM.....	EA	2
91	17	XDDZZ		100-1K	75012	RESISTOR,VAR,WW	EA	2
91	18	XDDZZ		C20-222G	07115	RESISTOR,FXD,FILM.....	EA	2
91	19	XDDZZ		C20-242G	07115	RESISTOR,FXD,FILM.....	EA	2
91	20	PADZZ	5905-00-904-7081	C20-102G	16299	RESISTOR,FIXED,FILM.....	EA	3
91	21	PADZZ	5905-00-904-7083	C20-103G	16299	RESISTOR,FXD,FILM.....	EA	2
91	22	XDDZZ		C20-153G	07115	RESISTOR,FXD,FILM.....	EA	4
91	23	PADZZ	5940-00-990-1658	MS17122-6	96906	TERMINAL,STUD.....	EA	3
91	24	XDDZZ		44296	06809	PRINTED CKT BOARD	EA	1
91	25	PADZZ	5999-00-068-1987	TP501	08289	MOUNTING PAD,ELECTR.....	EA	2
91	26	PADZZ	5340-00-969-6501	NPC7	81074	CLAMP,LOOP	EA	1

241/(242 blank)

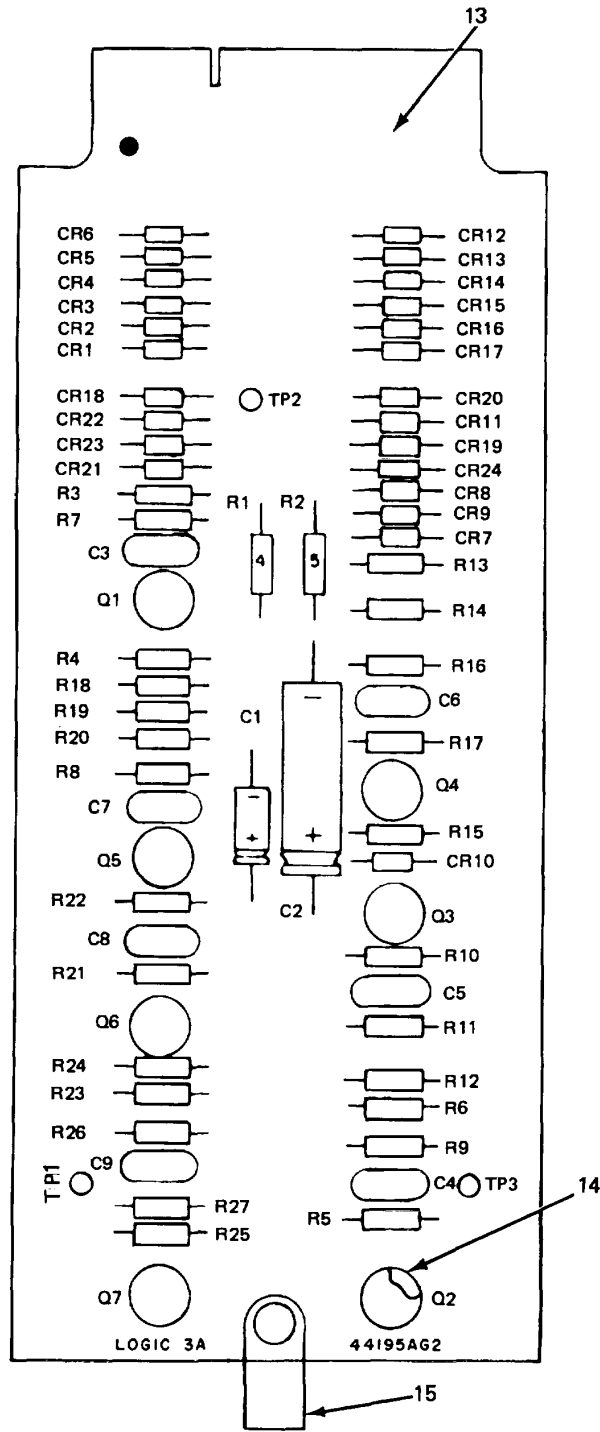

NOTE: PREFIX ALL REFERENCE DESIGNATIONS WITH A3A2B4
ELOQM110

Figure 92. Circuit Card Assembly A3A2B4 (Sheet 1 of 2).

REF. DES.	ITEM NO.	REF. DES.	ITEM NO.	REF. DES.	ITEM NO.	REF. DES.	ITEM NO.	REF. DES.	ITEM NO.	REF. DES.	ITEM NO.	REF. DES.	ITEM NO.
C1	1	CR2	4	CR12	4	CR22	4	R1	6	R11	11	R21	10
C2	2	CR3	4	CR13	4	CR23	4	R2	7	R12	11	R22	11
C3	3	CR4	4	CR14	4	CR24	4	R3	8	R13	10	R23	11
C4	3	CR5	4	CR15	4	Q1	5	R4	9	R14	8	R24	8
C5	3	CR6	4	CR16	4	Q2	5	R5	8	R15	9	R25	9
C6	3	CR7	4	CR17	4	Q3	5	R6	8	R16	10	R26	10
C7	3	CR8	4	CR18	4	Q4	5	R7	10	R17	11	R27	11
C8	3	CR9	4	CR19	4	Qs	5	R8	11	R18	8	TP1	12
C9	3	CR10	4	CR20	4	Q6	5	R9	10	R19	8	TP2	12
CR1	4	CR11	4	CR21	4	Q7	5	R10	10	R20	10	TP3	12

EL0QM111

Figure 92. Circuit Card Assembly A3A2B4 (Sheet 2 of 2).

SECTION II

(1) ILLUSTRATION		(2)	(3)	(4)	(5)	(6) DESCRIPTION	(7)	(8)
(a) FIG NO.	(b) ITEM NO.	SMR CODE	NATIONAL STOCK NUMBER	PART NUMBER	FSCM	USABLE ON CODE	U/M	QTY INC IN UNIT
						GROUP 120111 CIRCUIT CARD ASSEMBLY A3A2B4		
92	1	XDDZZ		NLW10-12	14655	CAPACITOR,ELCTLT	EA	1
92	2	PADZZ	5910-00-760-0516	NLW200-12	14655	CAPACITOR,FIXED,ELE	EA	1
92	3	PADZZ	5910-00-952-6432	CM06F561J03	81349	CAPACITOR,FXD,MICA.....	EA	7
92	4	PADZZ	5961-00-615-0095	1N276	81349	SEMICONDUCTOR DEVIC.....	EA	24
92	5	XDDZZ		1N404	81349	TRANSISTOR.....	EA	7
92	6	XDDZZ		EB2R75	01121	RESISTOR,FXD,CMPSN	EA	1
92	7	PADZZ	5905-00-190-8883	RC20GF100J	81349	RESISTOR,FIXED,COMP	EA	1
92	8	XDDZZ		C20-242G	07115	RESISTOR,FXD,FILM.....	EA	7
92	9	XDDZZ		C20-562G	16299	RESISTOR,FXD,FILM.....	EA	3
92	10	XDDZZ		C20-222G	07115	RESISTOR,FXD,FILM.....	EA	8
92	11	XDDZZ		C20-153G	07115	RESISTOR,FXD,FILM.....	EA	7
92	12	PADZZ	5940-00-990-1658	MS17122-6	96906	TERMINAL,STUD.....	EA	3
92	13	XDDZZ		44295	06809	PRINTED CIRCUIT BD	EA	1
92	14	PADZZ	5999-00-068-1987	TP501	08289	MOUNTING PAD,ELECTR.....	EA	1
92	15	PADZZ	5340-00-969-6501	NPC7	81074	CLAMP,LOOP	EA	1

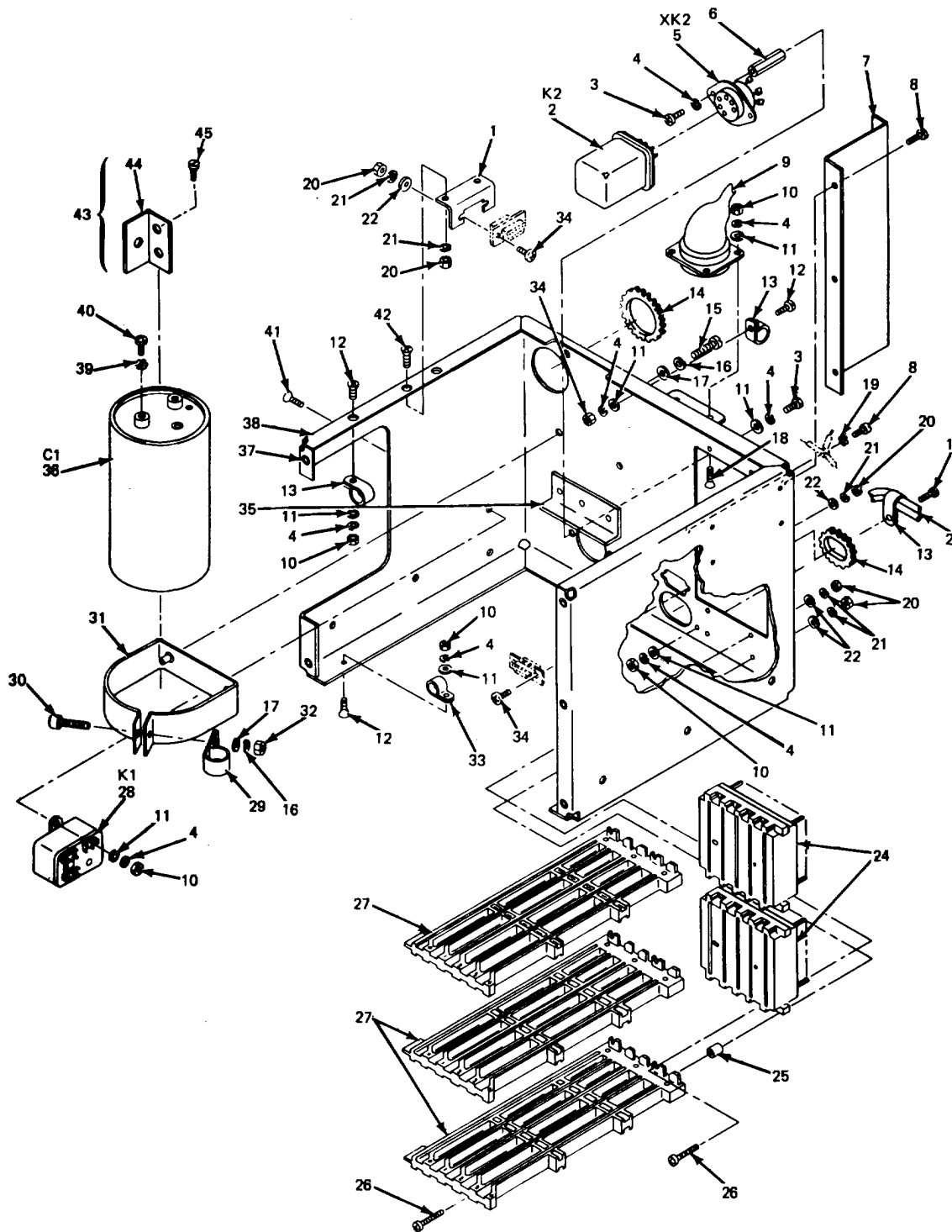

NOTE: PREFIX ALL REFERENCE DESIGNATIONS WITH A3A2

ELOQM112

Figure 93. Chassis, Electrical Equipment A3A2.

SECTION II

TM 11-7440-222-40P/NAVELEX 0967-LP-324-0480/TO 31W4-2G-84

(1) ILLUSTRATION		(2)	(3)	(4)	(5)	(6) DESCRIPTION	(7)	(8)
(a) FIG NO.	(b) ITEM NO.	SMR CODE	NATIONAL STOCK NUMBER	PART NUMBER	FSCM	USABLE ON CODE	U/M	QTY INC IN UNIT
						GROUP 120112 CHASSIS,ELECTRICAL EQUIPMENT A3A2		
93	1	XDHZZ		56313-1	06809	BRACKET,CONNECTOR.....	EA	1
93	2	XDHZZ		DPP11A	77342	RELAY.....	EA	1
93	3	PAHZZ	5305-00-054-6652	MS51957-28	96906	SCREW,MACHINE.....	EA	4
93	4	PAHZZ	5310-00-929-6395	M35338-136	96906	WASHER,LOCK.....	EA	12
93	5	PAHZZ	5935-00-321-5113	77M1P8	02660	SOCKET,PLUG-IN ELEC.....	EA	1
93	6	XDHZZ		8222S0632-7	06540	SPACER,TAPPEO.....	EA	2
93	7	XDHZZ		52805-1	06809	GUARD,REAR.....	EA	1
93	8	PAHZZ	5305-00-054-6668	MS51957-43	96906	SCREW,MACHINE.....	EA	8
93	9	XDHHH		40640G1	06809	CABLE ASSEMBLY.....	EA	1
93	10	PAHZZ	5310-00-934-9761	MS35649-264	96906	NUT,PLAIN,HEXAGON.....	EA	18
93	11	PAHZZ	5310-00-531-9514	AN960C6	88044	WASHER,FLAT.....	EA	4
93	12	PAHZZ	5305-00-054-6653	MS51957-29	96906	SCREW,MACHINE.....	EA	3
93	13	XDHZZ		NPC9	81074	CLAMP,LOOP.....	EA	3
93	14	XDHZZ		G51PB	03296	GROMMET,RUBBER.....	EA	1
93	15	PAHZZ	5305-00-054-6671	MS51957-46	96906	SCREW,MACHINE.....	EA	2
93	16	PAHZZ	5310-00-933-8119	MS35338-137	96906	WASHER,LOCK.....	EA	3
93	17	PAHZZ	5310-00-685-3744	AN960C8	88044	WASHER,FLAT.....	EA	3
93	18	XDHZZ	5305-00-719-5064	MS51959-30	96906	SCREW,MACHINE.....	EA	10
93	19	PAHZZ	5310-00-614-3552	MS35335-59	96906	WASHER,LOCK.....	EA	4
93	20	PAHZZ	5310-00-271-4642	MS35649-44	96906	WASHER.....	EA	16
93	21	PAHZZ	5310-00-933-8118	MS35338-135	96906	WASHER,LOCK.....	EA	16
93	22	PAHZZ	5310-00-632-6721	AN96004	88044	WASHER,FLAT.....	EA	14
93	23	XDHHH		40638G1	06809	CABLE ASSEMBLY.....	EA	1
93	24	XDHZZ		63130	06809	CONNECTOR UNIT,RCPT.....	EA	2
93	25	XDHZZ		95605	06809	SPACER,SLEEVE.....	EA	4
93	26	PAHZZ	5305-00-054-5654	MS51957-20	96906	SCREW,MACHINE.....	EA	12
93	27	XDHZZ		52795-1	06809	GUIDE,CARD.....	EA	3
93	28	PAHZZ	5945-00-102-5807	91252-126	80089	RELAY,ARMATURE.....	EA	1
93	29	XDHZZ		NPC8	81074	CLAMP,LOOP.....	E.A	1
93	30	PAHZZ	5305-00-988-7605	MS16995-29	96906	SCREW,CAP,SOCKET HE.....	EA	1
93	31	XDHZZ		56254G1	06809	BRACKET,CAP.....	EA	1
93	32	PAHZZ	5310-00-934-9759		96906	NUT,PLAIN,HEXAGON.....	EA	1
93	33	XDHZZ		NPC6	81074	CLAMP,LOOP.....	EA	1
93	34	PAHZZ	5310-00-763-7822	MS51959-14	96906	SCREW,MACHINE.....	EA	2
93	35	XDHZZ		56566-2	06809	BRACKET,ANGLE.....	EA	1
93	36	PAHZZ	5910-00-988-0358	86F262MA	06001	CAPACITOR,FIXED,ELE.....	EA	1
93	37	PAHZZ	5310-00-988-0358	79NCFMA2-82	72962	CHASSIS,BLANK.....	EA	1

SECTION II

TM 11-7440-222-40P/NAVELEX 0967-LP-324-0480/TO 31W4-2G-84

(1) ILLUSTRATION		(2)	(3)	(4)	(5)	(6)	(7)	(8)
(a) FIG NO.	(b) ITEM NO.	SMR CODE	NATIONAL STOCK NUMBER	PART NUMBER	FSCM	DESCRIPTION USABLE ON CODE	U/M	QTY INC IN UNIT
93	39	PAHZZ	5310-00-209-1239	MS35335-60	96906	WASHER, LOCK	EA	2
93	40	PAHZZ	5305-00-059-3657	MS51958-61	96906	SCREW, MACHINE	EA	2
93	41	PAHZZ	5305-00-763-6963	MS51959-28	96906	SCREW, MACHINE	EA	1
93	42	PAHZZ	5305-00-770-2579	MS51959-15	96906	SCREW, MACHINE	EA	2
93	43	XDHHH		A1-11864B	14850	SHIELD ASSEMBLY	EA	1
93	44	XDHZZ		D1-10982B	14850	SHIELD	EA	1
93	45	XDHZZ		A1-10977F-4	14850	SCREW, MACHINE	EA	3

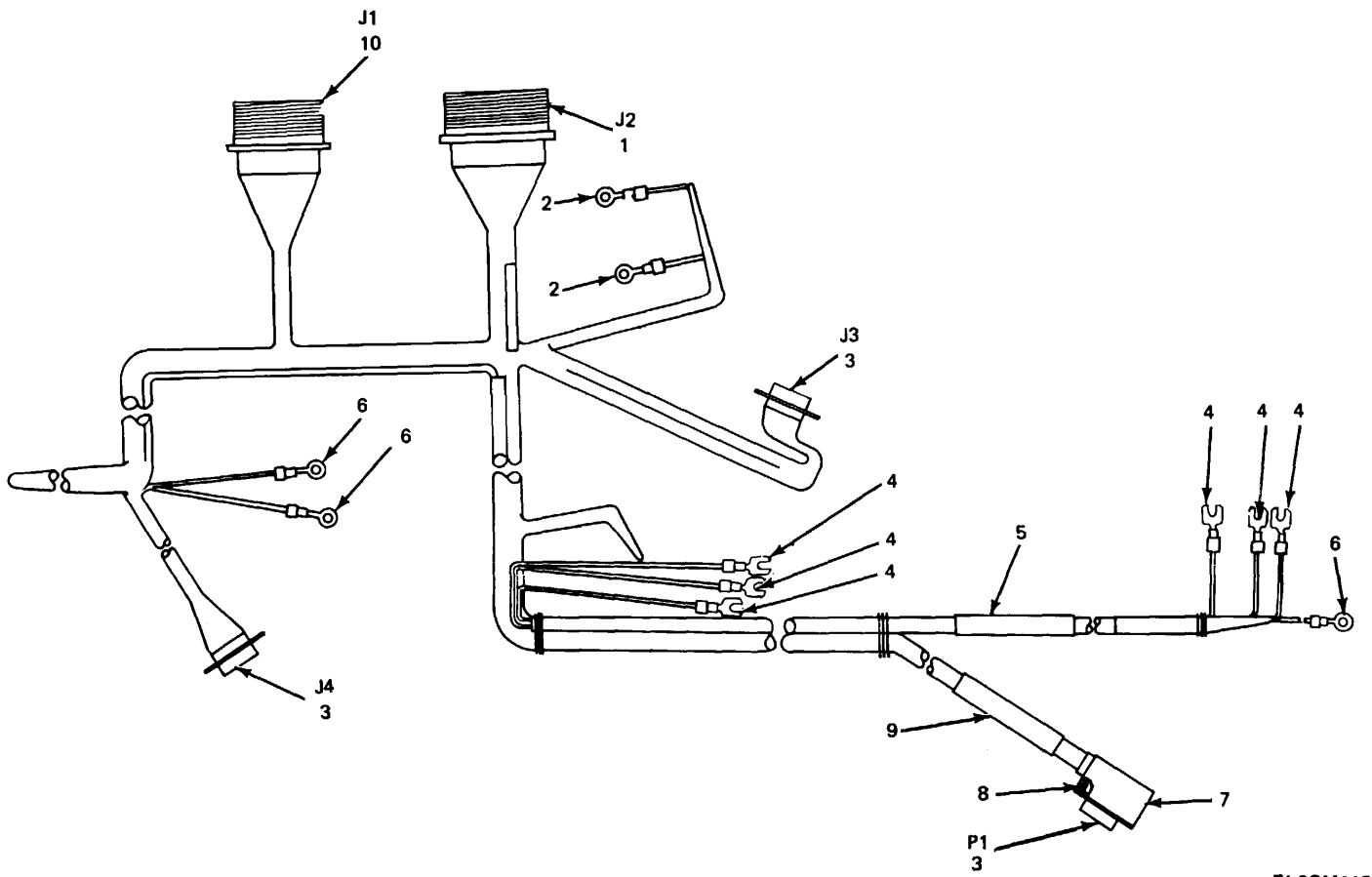

ELOQM113

Figure 94. Cable Assembly (40640G1).

SECTION II

(1) ILLUSTRATION		(2)	(3)	(4)	(5)	(6) DESCRIPTION	(7)	(8)
(a) FIG NO.	(b) ITEM NO.	SMR CODE	NATIONAL STOCK NUMBER	PART NUMBER	FSCM	USABLE ON CODE	U/M	QTY INC IN UNIT
						GROUP 12011201 CABLE ASSEMBLY (40640G1)		
94	1	PAHZZ	5935-00-725-0888	MS3102R28-12P	96906	CONNECTOR,RECEPTACL.....	EA	1
94	2	PAHZZ	5940-00-143-4794	RC363	59730	TERMINAL,LUG	EA	2
94	3	PAHZZ	5935-00-156-9255	DE9S	71468	CONNECTOR,RECEPTACL.....	EA	3
94	4	PAHZZ	5940-00-578-0905	RB1203	59730	TERMINAL,LUG	EA	6
94	5	XDHZZ		56626-9	06809	MARKER,CABLE.....	EA	1
94	6	XDHZZ		RB863	02032	TERMINAL,LUG	EA	3
94	7	PAHZZ	5935-00-816-8713	DE90JS19977-5	71468	SHIELD,ELECTRICAL C	EA	1
94	8	PAHZZ	5305-00-770-2533	MS51959-13	96906	SCREW,MACHINE.....	EA	2
94	9	XDHZZ		56626-12	06809	MARKER,CABLE.....	EA	1
94	10	XDHZZ		MS102R24-28P	96906	CONNECTOR,RCPT,ELEC.....	EA	1

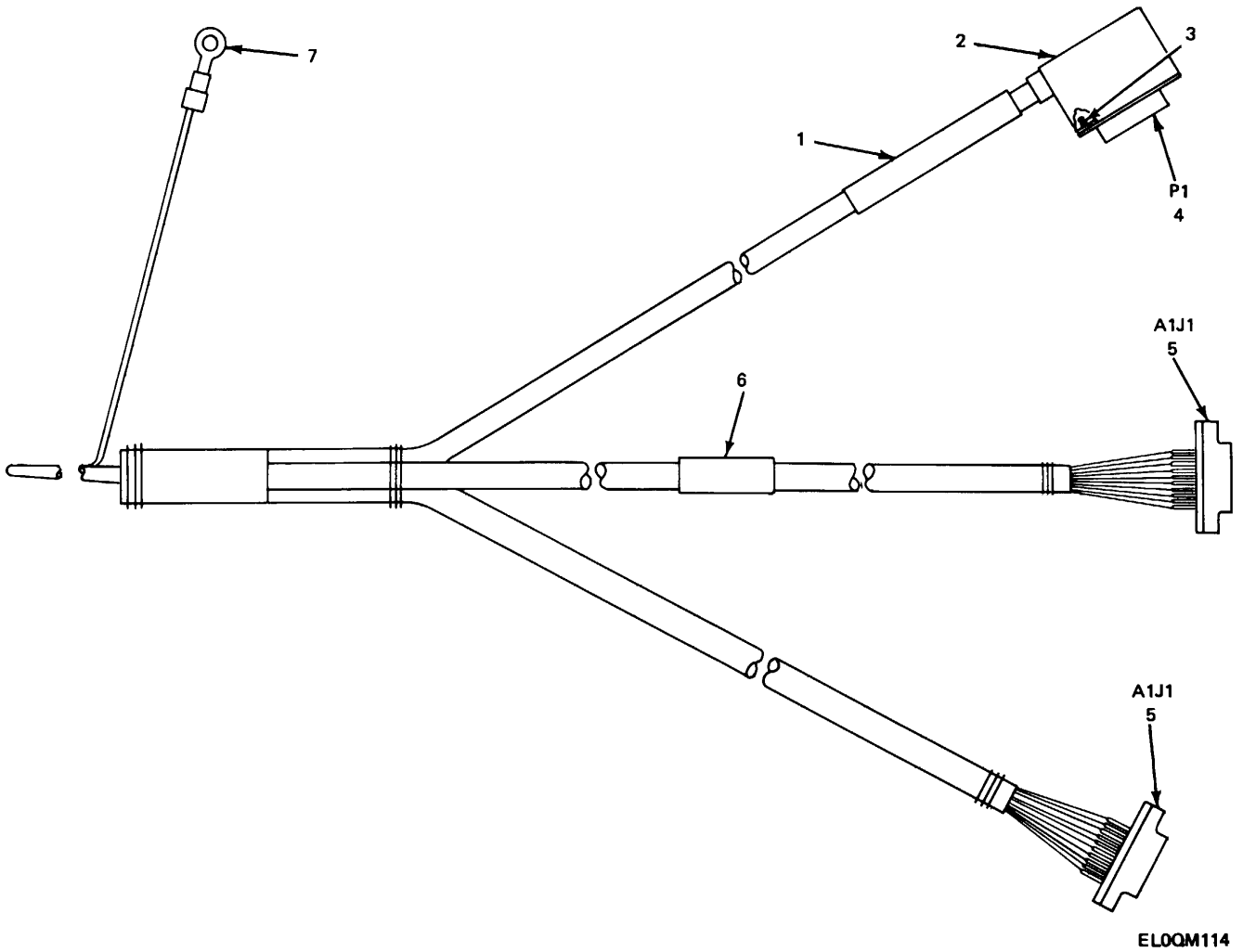
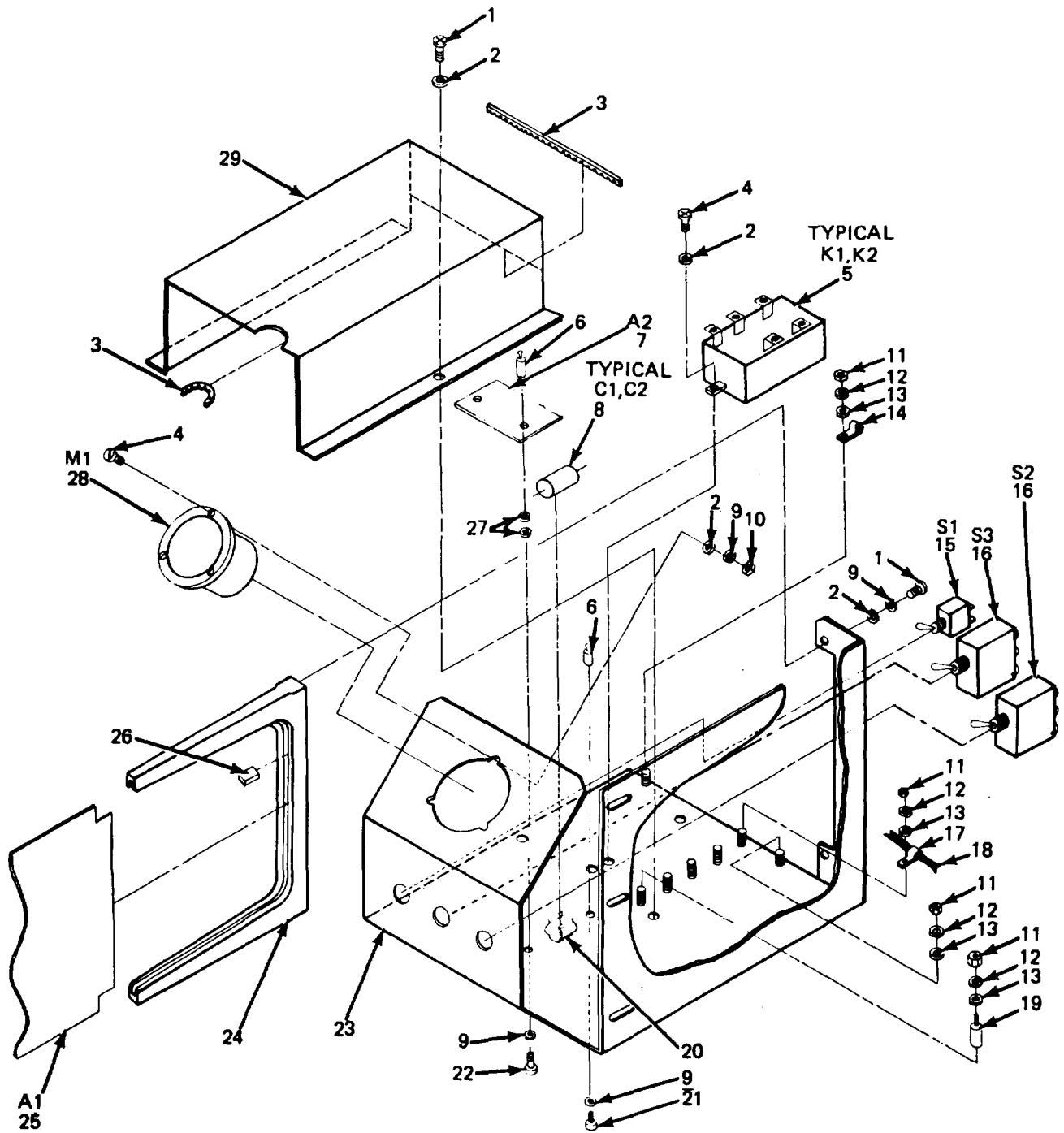

Figure 95. Cable Assembly (40638G1).

SECTION II

TM 11-7440-222-40P/NAVELEX 0967-LP-324-0480/TO 31W4-2G-84

(1) ILLUSTRATION		(2)	(3)	(4)	(5)	(6)	(7)	(8)
(a) FIG NO.	(b) ITEM NO.	SMR CODE	NATIONAL STOCK NUMBER	PART NUMBER	FSCM	DESCRIPTION USABLE ON CODE	U/M	QTY INC IN UNIT
						GROUP 12011202 CABLE ASSEMBLY (40638G1)		
95	1	XDHZZ		56626-4	06809	MARKER,CABLE.....	EA	1
95	2	PAHZZ	5935-00-816-8713	DE90JS19977-5	71468	SHELL,PLUG	EA	1
95	3	PAHZZ	5305-00-770-2533	MS51959-13	96906	SCREW,MACHINE.....	EA	2
95	4	PAHZZ	5935-00-156-9255	DE9S	71468	CONNECTOR,RECEPTACL	EA	1
95	5	PAHZZ	5935-00-118-4841	A2389-20-1-0	16512	CONNECTOR,RECEPTACL	EA	2
95	6	XDHZZ		56626-6	06809	MARKER,CABLE.....	EA	1
95	7	XDHZZ		RB863	02032	TERMINAL,LUG	EA	1



NOTE: PREFIX ALL REFERENCE DESIGNATIONS WITH A5

ELOQM115

Figure 96. Motor Stop Assembly A5.

SECTION II

TM 11-7440-222-40P/NAVELEX 0967-LP-324-0480/TO 31W4-2G-84

(1) ILLUSTRATION		(2)	(3)	(4)	(5)	(6)	(7)	(8)
(a) FIG NO.	(b) ITEM NO.	SMR CODE	NATIONAL STOCK NUMBER	PART NUMBER	FSCM	DESCRIPTION USABLE ON CODE	U/M	QTY INC IN UNIT
						GROUP 13 MOTOR STOP ASSEMBLY A5		
96	1	PAHZZ	5305-00-054-6652	MS51957-28	96906	SCREW,MACHINE.....	EA	2
96	2	PAHZZ	5310-00-638-9857	AN960C6L	88044	WASHER,FLAT	EA	2
96	3	XDHZZ	5325-00-074-3301	WG-201	95987	GROMMET,PLASTIC.....	EA	1
96	4	PAHZZ	5310-00-054-6654	MS51957-30	96906	SCREW,MACHINE.....	EA	3
96	5	PAHZZ	7040-00-451-8256	GB7200-4	24211	ELECTRONIC SWITCH	EA	2
96	6	PAHZZ	5940-00-068-0745	540027-006	12436	TERMINAL,STUD.....	EA	4
96	7	PAHDL	7040-00-025-8824	12-890129-1	12436	CIRCUIT CARD ASSEMB.....	EA	1
96	8	PAHZZ	5910-00-881-8268	CP09A1KF474K3	81349	CAPACITOR,FIXED,PAP	EA	2
96	9	PAHZZ	5310-00-929-6395	MS35338-136	96906	WASHER,LOCK	EA	2
96	10	PAHZZ	5310-00-934-9761	MS35649-264	96906	NUT,PLAIN,HEXAGON.....	EA	3
96	11	PAHZZ	5310-00-934-9759	MS35649-284	96906	NUT,PLAIN,HEXAGON.....	EA	4
96	12	PAHZZ	5310-00-93-8119	MS35338-137	96906	WASHER,LOCK	EA	4
96	13	PAHZZ	5310-00-558-6207	AN960C8L	88044	WASHER,FLAT	EA	4
96	14	PAHZZ	5340-00-515-0136	HP18N	09922	CLAMP,LOOP	EA	2
96	15	PAHZZ	5930-00-913-2983	MS90311-231	96906	SWITCH,TOGGLE	EA	1
96	16	PAHZZ	5930-00-655-1582	MS35059-23	96906	SWITCH,TOGGLE	EA	2
96	17	XDHZZ	5340-00-290-7273	HP-12N	09922	CLAMP,LOOP	EA	1
96	18	XDHHH		00-001585-2	06809	CABLE ASSEMBLY.....	EA	1
96	19	XDHZZ	5970-01-035-2869	04-001393	12436	STANDOFF	EA	5
96	20	PAHZZ	5340-00-051-6706	MS17160-30	96906	CLIP,SPRING TENSION.....	EA	2
96	21	PAHZZ	5305-00-054-6650	MS51957-26	96906	SCREW,MACHINE.....	EA	1
96	22	PAHZZ	5305-00-054-0655	MS51957-31	96906	SCREW,MACHINE.....	EA	2
96	23	XDHZZ		01-002882-2	06809	FRAME,MOUNTING.....	EA	1
96	24	PAHZZ	5935-00-102-5690	200150-02	16512	CONNECTOR,RECEPTACL.....	EA	1
96	25	PAHDL	7040-00-025-8836	12-890096-2	12436	CIRCUIT CARD ASSEMB.....	EA	1
96	26	XDHZZ		290050-1	16512	KEY,POLARIZATION	EA	1
96	27	XDHZZ		540911-13	58189	WASHER,FIBER	EA	6
96	28	PAHZZ	6645-00-089-8842	M5659	74400	METER,TIMING.....	EA	1
96	29	XDHZZ		01-002883-2	06809	COVER,RELAY	EA	1

255/(256 blank)

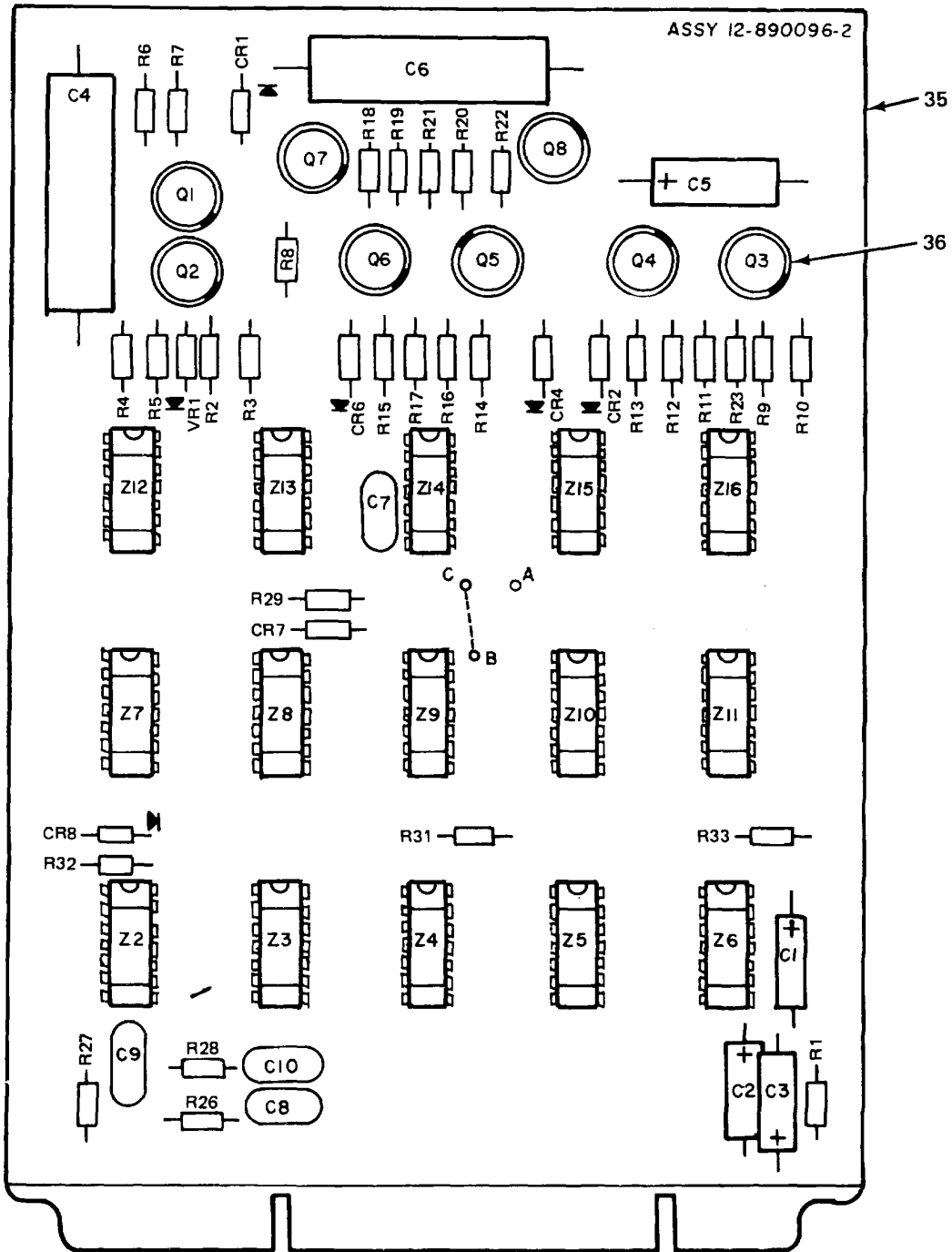

NOTE: PREFIX ALL REFERENCE DESIGNATIONS WITH A5A1

EL0QM116

Figure 97. Circuit Card Assembly A5A1 (Sheet 1 of 2).

REF. DES.	ITEM NO.	REF. DES.	ITEM NO.	REF. DES.	ITEM NO.	REF. DES.	ITEM NO.	REF. DES.	ITEM NO.	REF. DES.	ITEM NO.	REF. DES.	ITEM NO.
C1	1	CR1	7	Q5	11	R7	16	R17	23	R29	26	Z7	33
C2	1	CR2	7	Q6	11	R8	18	R18	24	R31	27	Z8	34
C3	1	CR4	8	Q7	10	R9	19	R19	16	R32	28	Z9	33
C4	2	CR6	8	Q8	9	R10	20	R20	16	R33	29	Z10	33
C5	3	CR7	7	R1	12	R11	21	R21	22	VR1	30	Z11	33
C8	4	CR8	7	R2	13	R12	16	R22	25	Z2	31	Z12	34
C7	5	Q1	9	R3	14	R13	22	R23	22	Z3	32	Z13	34
C8	6	Q2	9	R4	15	R14	16	R26	16	Z4	33	Z14	33
C9	6	Q3	9	R5	16	R15	16	R27	16	Z5	33	Z15	34
C10	6	Q4	10	R6	17	R16	23	R28	16	Z6	33	Z16	34

EL0QM117

Figure 97. Circuit Card Assembly A5A1 (Sheet 2 of 2).

SECTION II

TM 11-7440-222-40P/NAVELEX 0967-LP-324-0480/TO 31W4-2G-84

(1) ILLUSTRATION		(2)	(3)	(4)	(5)	(6)	(7)	(8)
(a) FIG NO.	(b) ITEM NO.	SMR CODE	NATIONAL STOCK NUMBER	PART NUMBER	FSCM	DESCRIPTION USABLE ON CODE	U/M	QTY INC IN UNIT
						GROUP 1301 CIRCUIT CARD ASSEMBLY A5A1		
97	1	XDDZZ		DSL3BE106N	81149	CAPACITOR,TANTALUM.....	EA	3
97	2	PADZZ	5910-00-655-0137	CP09A1K84T3K3	81349	CAPACITOR, FIXED, PAP	EA	1
97	3	PADZZ	5910-00-899-9129	CS13DD686M	81349	CAPACITOR, FIXED, ELE	EA	1
97	4	PADZZ	5910-00-899-4395	CP09A1KB104K3	81349	CAPACITOR, FIXED, PAP	EA	1
97	5	PADZZ	5910-00-081-8526	CM05F391J03	81349	CAPACITOR, FIXED, MIC.....	EA	1
97	6	PADZZ	5910-00-954-7368	CM05F241J03	81349	CAPACITOR, FXD, MICA.....	EA	3
97	7	PADZZ	5961-00-814-0768	JAN1N3064	81349	SEMICONDUCTOR DEVIC.....	EA	4
97	8	PADZZ	5961-00-851-8293	1N5059	80131	SEMICONDUCTOR, DIODE	EA	2
97	9	PADZZ	5961-00-949-1432	JAN2N2219	81349	TRANSISTOR.....	EA	4
97	10	PADZZ	5961-00-926-2569	JAN2N491A	81349	TRANSISTOR.....	EA	2
97	11	PADZZ	5961-00-851-8293	JAN2N1041	81349	TRANSISTOR.....	EA	2
97	12	PADZZ	5905-00-681-6462	RC07GF102J	81349	RESISTOR, FIXED, COMP	EA	1
97	13	PADZZ	5905-00-801-6444	RC07GF911J	81349	RESISTOR, FIXED, COMP	EA	1
97	14	PADZZ	5905-00-686-3369	RC07GF331J	81349	RESISTOR, FIXED, COMP	EA	1
97	15	PADZZ	5905-00-687-0000	RC07GF183J	81349	RESISTOR, FIXED, COMP	EA	1
97	16	PADZZ	5905-00-683-2236	RC07GF391J	81349	RESISTOR, FIXED, COMP	EA	10
97	17	PADZZ	5905-00-683-2246	RC07GF473J	81349	RESISTOR, FIXED, COMP	EA	1
97	18	PADZZ	5905-00-726-4413	RC07GF123J	81349	RESISTOR, FIXED, COMP	EA	1
97	19	PADZZ	5905-00-723-5251	RC07GF222J	81349	RESISTOR, FIXED, COMP	EA	1
97	20	PADZZ	5905-00-687-0002	RC07GF223J	81349	RESISTOR, FIXED, COMP	EA	1
97	21	PADZZ	5905-00-683-2238	RC07GF103J	81349	RESISTOR, FIXED, COMP	EA	1
97	22	PADZZ	5905-00-683-7721	RC07GF101J	81349	RESISTOR, FIXED, COMP	EA	3
97	23	PADZZ	5905-00-686-3798	RC07GF272J	81349	RESISTOR, FIXED, COMP	EA	2
97	24	PADZZ	5905-00-721-0597	RC07GF243J	81349	RESISTOR, FIXED, COMP SELECT	EA	1
97	24	PADZZ	5905-00-687-0000	RC07GF183J	81349	RESISTOR, FIXED, COMP SELECT	EA	1
97	24	PADZZ	5905-00-686-3368	RC07GF203J	81349	RESISTOR, FIXED, COMP SELECT	EA	1
97	24	PADZZ	5905-00-687-0002	RC07GF223J	81349	RESISTOR, FIXED, COMP SELECT	EA	1
97	24	PADZZ	5903-00-119-3504	RC07GF273J	81349	RESISTOR, FIXED, COMP SELECT	EA	1
97	25	PADZZ	5905-00-683-2240	RC07GF221J	81349	RESISTOR, FIXED, COMP	EA	1
97	26	PADZZ	5905-00-691-0195	RC07GF562J	81349	RESISTOR, FIXED, COMP	EA	1
97	27	PADZZ	5905-00-682-4098	RC07GF392J	81349	RESISTOR, FIXED, COMP	EA	1
97	28	PADZZ	5905-00-116-2394	RC07GF511J	81349	RESISTOR, FIXED, COMP	EA	1
97	29	PADZZ	5905-00-686-3370	RC07GF202J	81349	RESISTOR, FIXED, COMP	EA	1
97	30	PADZZ	5961-00-995-2310	JAN1N52A	81349	SEMICONDUCTOR DEVIC.....	EA	1
97	31	PADZZ	5962-00-007-4099	SN7402J	01295	INTEGRATED CIRCUIT	EA	1
97	32	PADZZ	5962-00-477-9459	SN7410J	01295	INTEGRATED CIRCUIT	EA	1
97	33	PADZZ	5962-00-477-9455	SN7400J	01295	MICROCIRCUIT, DIGITA	EA	8
97	34	PADZZ	5962-00-470-1637	SN7474	02951	MICROCIRCUIT, DIGITA	EA	5
97	35	XDDZZ		12-870096-2	06809	PRINTED CIRCUIT BD	EA	1
					259			

SECTION II

TM 11-7440-222-40P/NAVELEX 0967-LP-324-0408/TO 31W4-2G-84

(1) ILLUSTRATION		(2)	(3)	(4)	(5)	(6)	(7)	(8)
(a) FIG NO.	(b) ITEM NO.	SMR CODE	NATIONAL STOCK NUMBER	PART NUMBER	FSCM	DESCRIPTION USABLE ON CODE	U/M	QTY INC IN UNIT
97	36	PADZZ	5999-00-946-0947	10079	07047	MOUNTING PAD,ELECTR..... 260/(261blank)	EA	8

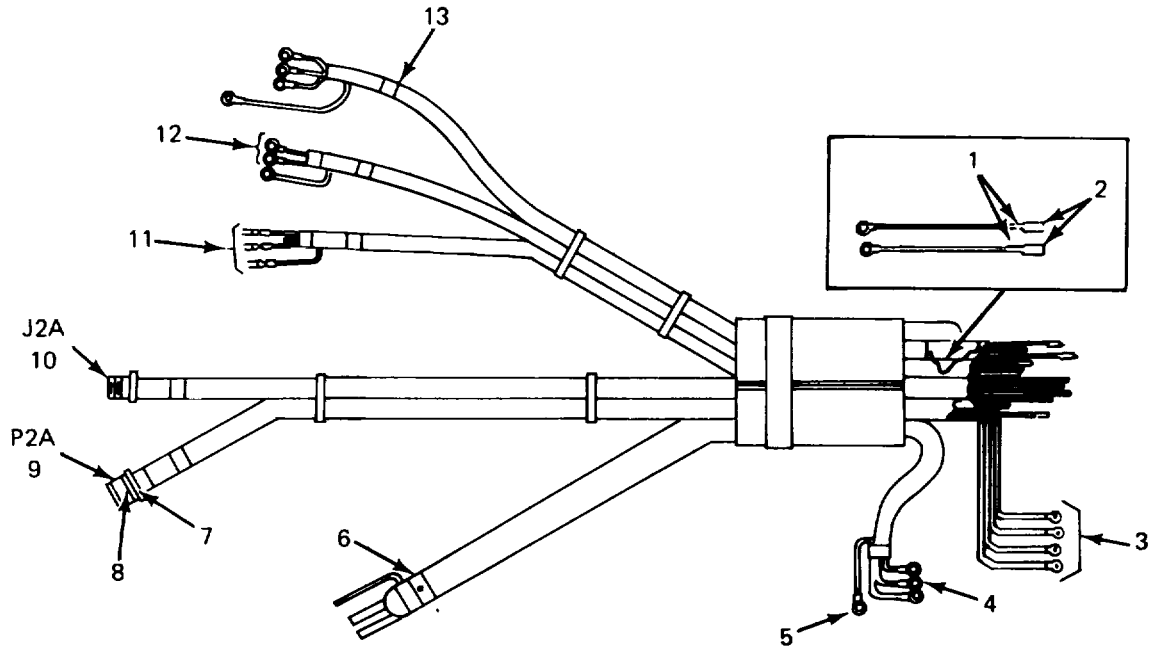

CABLE ASSEMBLY

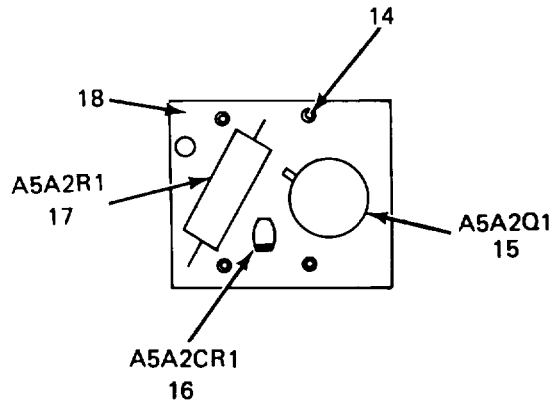

CIRCUIT CARD

EL0QM118

Figure 98. Cable Assembly (00-001585-2) and Circuit Card Assembly A5A2.

SECTION II

TM 11-7440-222-40P/NAVELEX 0967-LP-324-0408/TO 31W4-2G-84

(1) ILLUSTRATION		(2)	(3)	(4)	(5)	(6) DESCRIPTION	(7)	(8)
(a) FIG NO.	(b) ITEM NO.	SMR CODE	NATIONAL STOCK NUMBER	PART NUMBER	FSCM	USABLE ON CODE	U/M	QTY INC IN UNIT
						GROUP 1302 CABLE ASSEMBLY (00-001585-21		
98	1	XDHZZ		61380-1	00T79	RECEPTACLE, SPADE.....	EA	2
98	2	XDHZZ		1-480416-0	00779	CONNECTOR BODY, RECE.....	EA	2
98	3	XDHZZ		60524-3	00779	RECEPTACLE, TERMINAL.....	EA	47
98	4	PAHZZ	5940-00-204-8966	MS25036-102	96906	TERMINAL, LUG	EA	22
98	5	XDHZZ		MSI5036-149	96906	TERMINAL, LUG	EA	15
98	6	XDHZZ		TC125	59730	NAMEPLATE	EA	5
98	7	PAHZZ	5365-00-741-6944	AN3420-1	88044	BUSHING, RUBBER	EA	1
98	8	PAHZZ	5365-00-663-2125	AN3420-10	88044	BUSHING, RUBBER	EA	1
98	9	PAHZZ	5935-00-726-4525	CA06R22-14S	71468	CONNECTOR, PLUG, ELEC	EA	1
98	10	PAHZZ	5935-00-721-0496	MS3102R22-14P	96906	CONNECTOR, RECEPTACL	EA	1
98	11	PAHZZ	7440-00-019-3468	540362-06	16512	CONTACT, ELECTRICAL	EA	3
98	12	PAHZZ	5940-00-143-4771	MS25036-103	96906	TERMINAL, LUG	EA	6
98	13	PAHZZ	5975-00-497-2157	MS172821-1-9	96906	STRAP	EA	5
						GROUP 1303 CIRCUIT CARD ASSEMBLY A5A2		
98	14	XDHZZ		SMB546534	80063	TERMINAL	EA	4
98	15	PADZZ	5961-00-081-4816	JAN2N1485	81349	TRANSISTOR.....	EA	1
98	16	PADZZ	5961-00-088-8792	1N5059	80131	SEMICONDUCTOR, DIODE	EA	1
98	17	PADZZ	5905-00-951-8105	RW67V270	81349	RESISTOR, FIXED, WIRE	EA	1
98	18	XDDZZ		12-870129	06809	PRINTED CKT BOARD	EA	1
					263			

SECTION IV

TM 11-7440-222-40P/NAVELEX 0967-LP-324-0408/TO 31W4-2G-84

NATIONAL STOCK NUMBER INDEX

NOTE: LATEST NATIONAL STOCK NUMBER AND PART NUMBER ASSIGNMENTS ARE INCLUDED AT END OF

INDEX.

STOCK NUMBER	FIG. NO.	ITEM NO.	STOCK NUMBER	FIG. NO.	ITEM NO.
5910-00-007-2004	62	11	7040-00-054-3412	36	9
5910-00-009-4597	89	1	7035-00-054-3414	35	3
6210-00-011-9338	23	30	7035-00-054-3414	36	3
5310-00-013-4524	47	5	7040-00-054-3415	33	3
5310-00-013-4530	47	14	7040-00-054-3415	34	3
7040-00-018-9637	47	41	1440-00-054-3423	31	68
7040-00-018-9638	47	44	7440-00-504-3423	81	28
7040-00-018-9690	56	23	7040-00-054-3429	35	31
7040-00-018-9706	47	20	7040-00-054-3430	33	31
7040-00-019-1988	73	16	7040-00-054-3435	39	7
7040-00-019-2002	74	31	7040-00-054-3440	30	44
7040-00-019-2004	76	26	5935-00-054-4172	5	6
7040-00-019-2098	73	63	5910-00-054-4225	47	56
7040-00-019-2225	32	52	5910-00-054-4241	47	47
7040-00-019-2247	32	53	5910-00-054-4242	47	45
7040-00-019-2248	32	47	5910-00-054-4243	47	40
3040-00-019-2370	31	76	5305-00-054-5635	34	4
			5305-00-054-5638	32	20
			5305-00-054-5639	27	5
			5305-00-054-5639	37	15
7040-00-019-3017	32	23	5305-00-054-5639	45	14
7040-00-019-3018	45	27	5305-00-054-5641	74	19
7040-00-019-3020	46	12	5305-00-054-5641	74	43
7040-00-019-3053	35	16	5305-00-054-5641	77	10
7040-00-019-3054	36	16	5305-00-054-5644	30	137
7040-00-019-3055	34	15	5305-00-054-5644	33	4
7040-00-019-3067	33	15	5305-00-054-5644	35	4
7040-00-019-3086	72	21	5305-00-054-5644	36	4
5999-00-019-3098	65	55	5305-00-054-5644	37	13
7440-00-019-3468	23	46			
7440-00-019-3468	58	26	5305-00-054-5647	69	4
7440-00-019-3468	98	11	5305-00-054-5647	70	4
7040-00-019-4687	74	61	5305-00-054-5648	31	51
7040-00-019-4699	74	58	5305-00-054-5648	37	10
6210-00-019-5599	23	29	5305-00-054-5648	47	37
5920-00-023-2926	27	23	5305-00-054-5645	81	11
7040-00-025-8824	96	7	5305-00-054-5649	27	29
7040-00-025-8836	96	25	5305-00-054-5649	30	139
5905-00-043-0381	55	37	5305-00-054-5649	65	22
7035-00-043-1238	74	83	5305-00-054-5649	73	70
7035-00-043-1325	77	1	5305-00-054-5649	74	51
5920-00-043-1425	57	13	5305-00-054-5649	75	10
5910-00-043-2933	4	2	5305-00-054-5649	76	15
5310-00-045-3296	47	60	5305-00-054-5651	1	67
5310-00-045-3299	47	70	5305-00-054-5651	27	37
5310-00-045-4007	47	17	5305-00-054-5651	47	4
5310-00-045-4007	53	7	5305-00-054-5651	74	9
5935-00-050-5307	53	10	5305-00-054-5652	27	21
5910-00-050-5330	47	21	5305-00-054-5652	30	127
5910-00-050-5331	47	13	5305-00-054-5652	65	10
5910-00-050-5332	47	35	5305-00-054-5654	93	26
5935-00-050-5387	47	43	5305-00-054-6650	32	59
5961-00-050-7499	8	3	5305-00-054-6650	40	15
5961-00-050-7499	17	9	5305-00-054-6650	45	6
			5305-00-054-6650	46	16
5905-00-050-7598	48	24	5305-00-054-6650	72	10
5905-00-051-0752	88	14	5305-00-054-6650	73	32
5340-00-051-6706	96	20	5305-00-054-6650	81	9
5305-00-051-6751	33	7	5305-00-054-6650	96	22
5305-00-051-6751	34	7	5305-00-054-6651	20	7
5305-00-051-6751	35	6	5305-00-054-6651	30	120
5305-00-051-6751	36	6	5305-00-054-6651	37	21
5905-00-051-8003	55	48	5305-00-054-6651	47	76
5905-00-051-8012	8	22	5305-00-054-6652	20	2
5365-00-052-1080	31	65	5305-00-054-6652	27	46
5365-00-052-1080	44	7	5305-00-054-6652	30	141
5365-00-052-1080	81	31	5305-00-054-6652	31	19
5950-00-052-2570	82	18	5305-00-054-6652	41	4
5305-00-052-6456	73	11	5305-00-054-6652	47	18
5305-00-052-6456	74	33	5305-00-054-6652	55	58
7040-00-053-1316	30	19	5305-00-054-6652	65	59
7040-00-053-1317	30	95	5305-00-054-6652	67	25
7040-00-053-1321	33	28	5305-00-054-6652	68	25
7040-00-053-1321	35	28	5305-00-054-6652	69	30
3020-00-053-1430	30	24	5305-00-054-6652	70	30
3950-00-053-1459	31	66	5305-00-054-6652	72	15
5310-00-054-1831	29	20	5305-00-054-6652	74	25
7040-00-054-3411	30	45	5305-00-054-6652	75	16
7040-00-054-3412	33	10	5305-00-054-6652	93	3
7040-00-054-3412	34	10	5305-00-054-6652	96	1
7040-00-054-3412	35	9			

SECTION IV

TM 11-7440-222-40P/NAVELEX 0967-LP-324-0408/TO 31W4-2G-84
NATIONAL STOCK NUMBER INDEX

STOCK NUMBER	FIG. NO.	ITEM NO.	STOCK NUMBER	FIG. NO.	ITEM NO.
5305-00-054-6653	52	18	5910-00-060-1187	8	1
5305-00-054-6653	53	5	5905-00-060-3731	62	21
5305-00-054-6653	54	4	3400-00-060-5386	19	8
5305-00-054-6653	75	1	5915-00-061-1346	59	18
5305-00-054-6653	93	12	5905-00-062-5037	B8	17
5305-00-054-6654	27	33	5910-00-064-0882	91	4
5305-00-054-6654	30	7	5961-00-068-0687	8	29
5305-00-054-6654	30	142	5940-00-068-0745	96	6
5305-00-054-6654	41	1	5999-00-068-1987	84	9
5305-00-054-6654	46	7	5999-00-068-1987	85	19
5305-00-054-6654	51	8	5999-00-068-1987	87	21
5305-00-054-6654	53	14	5999-00-068-1987	88	23
5305-00-054-6654	58	10	5999-00-068-1987	89	34
5305-00-054-6654	65	22	5999-00-068-1987	90	19
5305-00-054-6654	67	5	5999-00-068-1987	91	25
			5999-00-068-1987	92	14
5305-00-054-6654	96	4	5305-00-068-5276	30	55
5305-00-054-6655	27	38	5305-00-068-5276	76	12
5305-00-054-6655	37	5	5305-00-068-5410	74	73
5305-00-054-6655	46	4	5305-00-068-5414	31	50
5305-00-054-6655	47	15	5305-00-068-5414	32	11
5305-00-054-6655	65	17	5305-00-068-5414	73	65
5305-00-054-6655	67	18	5305-00-068-5414	76	31
5305-00-054-6655	68	18	5305-00-068-5414	83	4
5305-00-054-6655	69	23	5305-00-068-5414	8	24
5305-00-054-6655	70	23	5305-00-068-5414	89	31
5305-00-054-6655	73	29	5905-00-069-3914	48	16
5305-00-054-6655	96	22	5905-00-069-3914	49	29
5305-00-054-6656	27	11	5905-00-069-3916	50	21
5305-00-054-6656	31	48	5905-00-069-3917	88	16
5305-00-054-6656	66	3	5305-00-071-1322	64	7
5305-00-054-6657	21	18	5305-00-071-1322	74	47
5305-00-054-6657	51	4	5325-00-074-3301	96	3
5305-00-054-6657	59	3	3010-00-075-5737	27	26
5305-00-054-6666	45	37	7025-00-075-6778	75	12
5305-00-054-6668	27	41	7025-00-075-6778	76	17
5305-00-054-6668	47	72	5961-00-078-1650	62	23
5305-00-054-6668	93	8	5905-00-078-7777	17	24
5305-00-054-6669	1	12	5905-00-078-8293	55	35
5305-00-054-6669	60	2	5905-00-079-3561	55	20
5305-00-054-6670	1	28	5961-00-079-6951	46	20
5305-00-054-6670	47	32	5961-00-081-4816	98	15
5305-00-054-6671	26	4	5961-00-081-6103	48	5
5305-00-054-6671	30	81	5961-00-081-6103	49	4
5305-00-054-6671	58	6	5910-00-081-8526	97	5
5305-00-054-6671	72	12	5310-00-082-1404	47	16
5305-00-054-6671	93	15	5310-00-082-1404	56	19
5305-00-054-6672	21	1	7040-00-087-8439	31	9
5305-00-054-6672	25	5	7040-00-087-8439	31	37
5305-00-054-6672	30	108	7040-00-087-8439	82	19
5305-00-054-6672	58	2	7040-00-087-8455	31	7
5305-00-054-6672	58	40	7040-00-087-8455	31	27
5305-00-054-6673	59	14	7040-00-087-8464	31	28
5305-00-054-6674	76	7	7040-00-087-8464	82	25
7040-00-056-0092	30	18	7040-00-087-8465	31	12
7040-00-056-0133	33	22	7040-00-087-8465	31	34
7040-00-056-0133	35	22	7040-00-087-8465	82	20
7040-00-056-0135	32	63	7040-00-087-8495	44	1
7040-00-056-0164	32	55	7040-00-087-8495	81	22
5330-00-057-7769	30	93	5910-00-087-9000	55	6
5365-00-057-1778	31	78	5905-00-088-0635	50	19
5365-00-057-7778	81	30	5905-00-088-0636	53	2
5315-00-057-7797	39	11	5905-00-088-0636	54	14
5340-00-057-7803	39	5	5905-00-088-0636	56	34
5950-00-057-8140	31	4	7025-00-089-1898	30	101
5305-00-059-3655	26	16	5935-00-089-4856	29	3
5305-00-059-3657	1	31	6645-00-089-8842	96	28
5305-00-059-3657	93	40	7025-00-089-9386	33	21
5305-00-059-3658	26	12	7025-00-089-9386	35	21
5305-00-059-3659	1	64	5999-00-096-9985	65	2
5305-00-059-3659	24	22	5950-00-097-7508	47	57
5305-00-059-3659	64	2	5970-00-097-9580	53	15
5305-00-059-3660	1	22	5970-00-097-9580	55	56
5305-00-059-3660	19	2	5945-00-100-4743	47	33
5305-00-059-3660	47	74	5935-00-102-0129	53	8
5305-00-059-3660	64	9	5935-00-102-0130	52	6
5305-00-059-3660	71	2	5935-00-102-0131	52	8
5305-00-059-3661	19	9	5950-00-102-5675	1	6
5305-00-059-3665	21	8	5935-00-102-5690	27	13
3110-00-059-6189	30	21	5935-00-102-5690	96	24

SECTION IV

TM 11-7440-222-40P/NAVELEX 0967-LP-324-0408/TO 31W4-2G-84
NATIONAL STOCK NUMBER INDEX

STOCK NUMBER	FIG. NO.	ITEM NO.	STOCK NUMBER	FIG. NO.	ITEM NO.
5930-00-102-5733	22	5			
5945-00-102-5807	93	28	7040-00-152-0042	31	40
5910-00-102-8019	93	36	7040-00-152-0054	39	6
5950-00-102-8133	55	53	5935-00-156-9255	94	3
5910-00-102-9271	30	12	5935-00-156-9255	95	4
5910-00-102-9277	65	56	7040-00-157-8672	76	24
5905-00-104-8334	40	17	5910-00-159-7336	61	12
5905-00-104-8334	67	9	5910-00-159-7337	61	12
5905-00-104-8334	68	8	5910-00-159-7338	61	13
5905-00-104-8335	62	8	5910-00-159-7361	61	12
5905-00-104-8337	48	30	5961-00-161-3454	63	10
5905-00-104-8347	66	10	5315-00-162-4040	27	18
5905-00-104-8350	55	32	5910-00-164-9695	61	13
5999-00-104-8551	52	7	5910-00-165-2520	61	13
5999-00-104-8551	53	9	7025-00-165-6532	1	10
5999-00-104-8551	54	5	7040-00-165-6534	25	1
5905-00-105-1964	90	11	7035-00-165-6598	45	50
5905-00-106-1282	55	31	5310-00-167-0797	77	13
5961-00-107-0748	48	4	5310-00-167-0801	24	23
5961-00-107-0748	49	3	5310-00-167-0801	73	13
5961-00-107-0748	50	3	5310-00-167-0801	74	8
5905-00-107-0818	50	23	53L0-00-167-0812	1	21
5905-00-107-0818	55	47	5310-00-167-0812	19	4
5961-00-107-0819	49	5	5310-00-167-0812	21	9
5961-00-107-0820	50	2	5310-00-167-0812	23	36
5935-00-107-1283	46	15	5310-00-167-0812	26	11
5305-00-111-5185	38	1	5310-00-167-0812	30	109
5905-00-111-8357	50	14	5310-00-167-0812	64	8
5905-00-111-8357	55	19	5310-00-167-0812	71	3
5905-00-111-8357	56	27	5962-00-167-7897	4	7
5905-00-111-8357	62	19	5962-00-167-7897	5	5
5905-00-111-8357	67	15	5962-00-167-7897	16	6
5905-00-111-8357	68	15	7040-00-168-6906	31	59
5905-00-111-8357	69	15	7440-00-168-6908	31	56
7045-00-112-8748	45	70	7040-00-168-6910	30	104
5910-00-113-5499	14	6	7040-00-168-6911	30	50
5940-00-113-8199	1	50	7040-00-168-6912	32	41
5940-00-113-8199	28	2	5905-00-171-2002	69	7
5905-00-114-5393	62	8	5905-00-171-2005	70	20
5905-00-114-5489	62	8	5905-00-171-2006	49	10
5935-00-115-2273	29	6	5905-00-171-2006	56	24
5905-00-116-2394	15	9	5905-00-171-2006	70	11
5905-00-116-2394	17	19	7040-00-172-3638	31	62
5905-00-116-2394	97	28	5360-00-172-6468	33	29
5905-00-116-8568	49	28	5360-00-172-6468	35	29
5905-00-116-8568	50	26	5365-00-178-6043	31	79
7035-00-117-0418	30	41	5365-00-178-6043	81	29
5935-00-118-4841	95	5	5365-00-178-6044	31	42
5905-00-119-3504	97	24	5365-00-178-6044	33	25
7040-00-121-9078	33	18	5365-00-178-6044	35	25
7040-00-121-9078	34	18	5365-00-178-6044	45	29
7040-00-121-9078	35	18	5365-00-178-6044	82	1
7040-00-121-9078	36	18	5365-00-178-6045	30	28
6105-00-125-3309	46	8	5365-00-178-6045	31	43
5962-00-127-8116	90	6	5365-00-178-6045	33	26
7040-00-134-3713	8	37	5365-00-178-6045	35	26
7040-00-134-3717	8	36	5365-00-178-6045	45	18
7040-00-134-3718	8	38	5365-00-178-6045	82	2
7040-00-134-3723	8	44	6210-00-181-2532	23	25
7040-00-134-3724	8	45	6210-00-181-2533	23	25
7040-00-134-3725	8	35	6210-00-181-2535	23	25
7040-00-134-3774	30	92	5365-00-182-6731	31	44
6105-00-134-5596	60	1	5365-00-182-6731	33	27
5935-00-134-5628	29	24	5365-00-182-6731	35	27
5950-00-134-5811	31	24			
5999-00-134-5933	20	12	5365-00-182-6731	45	19
5935-00-137-7300	56	3	5365-00-182-6731	82	3
5935-00-137-7301	56	4	5360-00-182-6808	82	24
5935-00-137-7302	56	8	3120-00-182-8219	31	58
5935-00-137-7303	56	2	6210-00-183-0299	23	31
5999-00-139-2510	20	11	6210-00-183-0300	23	31
5340-00-141-6693	73	61	6210-00-183-0303	23	31
5365-00-141-6944	98	7	6210-00-183-0305	23	31
5910-00-142-6950	17	18	5310-00-183-4354	27	6
5940-00-143-4771	98	12	5310-00-183-4354	37	16
5940-00-144-1986	40	5	5310-00-183-4354	72	28
5940-00-144-1986	42	2	5905-00-185-8510	50	27
5940-00-144-1986	46	22	5905-00-185-8510	55	33
7040-00-152-0040	31	45	5905-00-165-8518	70	6
7040-00-152-0041	30	3	5905-00-186-3008	46	18

SECTION IV

TM 11-7440-222-40P/NAVELEX 0967-LP-324-0408/TO 31W4-2G-84
NATIONAL STOCK NUMBER INDEX

STOCK NUMBER	FIG. NO.	ITEM NO.	STOCK NUMBER	FIG. NO.	ITEM NO.
5905-00-186-3008	62	10	5905-00-252-5434	17	3
5905-00-186-3008	68	5	5305-00-253-5603	1	26
5305-00-188-0219	31	11	5905-00-254-7087	62	8
5905-00-190-8881	69	20	5905-00-256-0409	70	15
5905-00-190-8882	62	8	5340-00-257-0038	1	73
5905-00-190-8883	87	10	5365-00-263-5954	74	65
5905-00-190-8883	89	25	5325-00-263-6641	45	5
5905-00-190-8883	91	12	5310-00-264-1390	47	49
5905-00-190-8883	92	7	5920-00-269-3743	57	10
5905-00-190-8887	48	10	5310-00-270-8810	19	5
5905-00-190-8897	49	14	5310-00-270-8810	29	19
5905-00-190-8887	50	20	5310-00-271-4642	58	32
5905-00-190-8889	49	25	5310-00-271-4642	63	4
5905-00-190-8889	55	44	5310-00-271-4642	73	39
5905-00-190-8889	56	28	5310-00-271-4642	93	20
5905-00-192-0649	29	IS	5905-00-279-1459	70	9
5905-00-192-0662	62	8	5905-00-279-1756	67	2
5905-00-192-3971	55	43	5905-00-279-1756	68	2
5905-00-192-3972	70	17	5905-00-279-1756	69	Z
5905-00-192-3973	48	19	5905-00-279-1757	48	14
5905-00-192-3973	49	24	5905-00-279-1757	49	11
5905-00-192-3973	50	15	5905-00-279-1757	50	11
5905-00-192-3973	55	22	5905-00-279-1757	55	26
5905-00-192-3987	62	8	5905-00-279-1869	67	12
5905-00-192-3988	62	8	5905-00-279-1869	70	2
5905-00-192-9260	62	8	5905-00-279-1876	55	30
5910-00-194-7807	41	10	5905-00-279-1889	49	17
5905-00-195-5571	8	12	5905-00-279-2115	65	50
5905-00-195-6451	62	2	5905-00-279-2616	50	17
5905-00-195-6502	62	13	5905-00-279-2616	55	27
5905-00-195-6502	69	8	5905-00-279-2627	8	27
5905-00-195-6758	62	8	5905-00-279-2642	29	14
5905-00-195-6806	48	9	5905-00-279-2672	67	3
5905-00-195-6806	49	19	5905-00-279-2672	68	3
5905-00-195-6806	55	17	5905-00-279-2672	69	6
5905-00-195-6817	40	11	5905-00-279-2672	70	7
5905-00-195-6817	62	12	5905-00-279-3504	49	12
5905-00-195-6817	67	13	5905-00-279-3504	55	18
5905-00-195-6817	68	12	5905-00-279-3505	48	18
5905-00-195-6817	69	17	5905-00-279-3506	48	15
5310-00-198-3724	51	6	5905-00-279-3506	55	28
5310-00-198-3724	56	18	5905-00-279-3512	48	8
5961-00-199-6008	52	5	5905-00-279-3517	48	13
5961-00-199-6008	53	3	5905-00-279-3517	49	23
5961-00-199-6008	55	16	5905-00-279-3518	56	31
5920-00-199-9502	57	8	5905-00-279-3521	55	42
5365-00-200-5234	30	13	5920-00-280-5002	57	4
5365-00-200-6707	73	17	5365-00-282-1633	31	77
5365-00-200-6707	73	57	5365-00-282-5322	77	2
5940-00-204-8966	98	4	5365-00-282-6297	30	132
5940-00-204-9142	22	10	5365-00-282-6297	45	58
5940-00-204-9142	28	5	5365-00-282-6297	45	74
5940-00-204-9142	58	42	5940-00-283-5280	30	90
5940-00-204-9414	65	52	5940-00-283-5280	30	119
5305-00-207-0763	62	14	5940-00-283-5280	30	144
5310-00-208-9255	74	98	5940-00-283-5280	46	6
5310-00-208-9255	79	10	5340-00-290-7273	1	63
5310-00-209-1239	93	39	5340-00-290-7273	96	17
5310-00-209-1366	30	149	5905-00-295-3410	62	8
5310-00-209-1366	72	6	5340-00-297-3841	74	11
5310-00-209-1366	73	33	5340-00-297-3841	74	56
5310-00-225-5328	65	35	5905-00-299-1541	55	21
5961-00-226-3717	52	4	7040-00-310-0884	32	62
5961-00-226-5139	17	26	5305-00-311-5341	38	*
			5305-00-316-0357	38	11
5905-00-226-7626	52	20			
5905-00-229-2620	62	8	5935-00-321-5113	65	32
7040-00-229-6570	45	45	5935-00-321-5113	93	5
5905-00-232-7800	48	11	5310-00-329-1307	47	63
5930-00-234-9199	22	6	7040-00-334-6006	1	1
5365-00-235-1003	31	17	5340-00-336-8164	1	51
5365-00-235-1003	31	29	5340-00-336-8164	1	62
5365-00-235-1005	31	21	5340-00-336-8164	27	40
5910-00-236-8745	17	2	5340-00-337-8642	1	53
5935-00-237-1389	29	23	5330-00-338-1280	31	2
5961-00-249-1583	69	26	5910-00-341-2437	46	19
5961-00-249-1583	70	26	5920-00-342-5828	57	12
5905-00-249-4248	62	8	7040-00-398-9663	45	57
5905-00-252-4018	55	23	7040-00-398-9663	45	71
5905-00-252-5428	66	7	5961-00-404-5592	89	12

SECTION IV

TM 11-7440-222-40P/NAVELEX 0967-LP-324-0408/TO 31W4-2G-84
NATIONAL STOCK NUMBER INDEX

STOCK NUMBER	FIG. NO.	ITEM NO.	STOCK NUMBER	FIG. NO.	ITEM NO.
7025-00-407-0743	82	9	5940-00-557-1629	58	44
7440-00-407-0744	82	4	5940-00-557-4346	58	16
5305-00-411-0683	30	17	5310-00-558-6207	1	13
7045-00-411-8654	30	4	5310-00-558-6207	21	3
7045-00-411-8654	30	58	5310-00-558-6207	25	4
5310-00-558-6207	26	6			
6150-00-416-8766	27	25	5310-00-558-6207	27	42
7025-00-432-2338	31	20	5310-00-558-6207	58	4
5340-00-439-5246	1	72	5310-00-558-6207	59	15
6105-00-442-6096	30	112	5310-00-558-6207	60	3
5935-00-451-7385	56	5	5310-00-558-6207	73	46
7040-00-451-8256	96	5	5310-00-558-6207	96	13
5340-00-451-9149	24	31	5355-00-559-8943	22	2
5910-00-455-4304	15	11	5340-00-560-9262	1	49
7040-00-455-5797	31	72	5340-00-560-9262	58	13
7040-00-455-7662	31	22	5305-00-576-7266	30	60
5945-00-465-9919	47	36	5940-00-577-3711	23	39
5961-00-468-3651	66	6	5940-00-577-3711	28	6
5961-00-468-3651	67	10	5940-00-577-3711	58	36
5961-00-468-3651	68	10	5961-00-577-6214	66	8
5961-00-468-3651	69	13	5961-00-577-6214	88	5
5961-00-468-3651	70	14	5961-00-577-6214	89	10
5962-00-470-1637	97	34	5905-00-577-7427	53	21
7035-00-472-3997	32	54	5905-00-577-9574	55	45
5999-00-476-6327	56	7	5940-00-578-0905	80	3
3040-00-477-8279	82	26	5940-00-578-0905	94	4
5962-00-477-9459	97	32	5905-00-578-0997	50	16
5940-00-478-0024	61	20	5905-00-578-0997	56	32
5935-00-478-7188	29	25	5305-00-582-6151	20	16
5961-00-481-7539	62	24	5930-00-583-8861	46	14
5305-00-483-0222	30	42	5930-00-583-8861	74	21
3040-00-489-0309	82	14	5930-00-583-8861	74	42
6210-00-497-2091	23	26	5930-00-583-8861	77	9
5975-00-497-2158	23	53	5310-00-595-6211	32	8
5975-00-497-2158	28	1	5310-00-595-6211	32	31
5975-00-497-2158	58	33	5310-00-595-6425	1	66
7025-00-497-8788	32	22	5310-00-595-6425	27	30
7025-00-497-8797	30	54	5310-00-595-6425	30	136
5940-00-501-5859	52	22	5310-00-595-6425	82	27
5940-00-502-8294	73	20	5310-00-596-8131	47	28
5905-00-504-4640	55	41	5310-00-596-8131	56	6
5340-00-515-0136	58	7	5340-00-598-0296	23	48
5340-00-515-0136	96	14	5305-00-601-9080	31	13
5310-00-515-7449	30	97	5305-00-601-9080	31	32
5310-00-527-3634	59	22	5305-00-601-9080	33	9
5310-00-531-9514	30	5	5305-00-601-9080	34	9
5310-00-531-9514	30	140	5305-00-601-9080	35	8
5310-00-531-9514	32	12	5305-00-601-9080	36	8
5310-00-531-9514	37	7	5305-00-601-9080	82	22
5310-00-531-9514	45	7	5310-00-614-3552	1	52
5310-00-531-9514	46	2	5310-00-614-3552	76	3
5310-00-531-9514	47	77	5310-00-614-3552	93	19
5310-00-531-9514	61	5	5961-00-615-0095	85	4
5310-00-531-9514	63	7	5961-00-615-0095	86	4
5310-00-531-9514	72	5	5961-00-615-0095	87	5
5310-00-531-9514	73	26	5961-00-615-0095	88	2
5310-00-531-9514	74	50	5961-00-615-0095	89	5
5310-00-531-9514	93	11	5961-00-615-0095	91	6
5310-00-531-9515	22	4	5961-00-615-0095	92	4
5310-00-531-9515	64	12	5935-00-615-6736	57	9
5905-00-542-9387	49	26	5935-00-615-6742	57	3
5310-00-543-2410	38	2	5310-00-616-3555	30	6
5310-00-543-2410	47	39	5310-00-616-3555	30	16
5310-00-543-2739	30	8	5310-00-616-3555	32	36
5310-00-543-2139	45	3	5310-00-616-3555	33	5
5310-00-543-4652	37	17	5310-00-616-3555	33	20
5310-00-543-4652	45	13	5310-00-616-3555	34	5
5310-00-543-5933	30	110	5310-00-616-3555	35	5
5310-00-550-3715	30	49	5310-00-616-3555	35	20
5310-00-550-3715	31	49	5310-00-616-3555	36	5
5310-00-550-3715	32	10	5310-00-616-3555	40	13
5310-00-616-3555	41	2			
5310-00-550-3715	88	25	5310-00-616-3555	45	8
5310-00-550-3715	89	32	5310-00-616-3555	46	3
5310-00-550-5054	45	11	5310-00-616-3555	62	15
5940-00-552-3635	56	13	5310-00-616-3555	81	10
3120-00-555-7544	74	68	5310-00-619-1148	29	21
5940-00-557-1627	58	43	5365-00-634-7444	44	2
5940-00-557-1627	59	8	5365-00-634-7444	82	12
5940-00-557-1628	59	19	5920-00-636-0970	57	6

SECTION IV

TM 11-7440-222-40P/NAVELEX 0967-LP-324-0408/TO 31W4-2G-84
NATIONAL STOCK NUMBER INDEX

STOCK NUMBER	FIG. NO.	ITEM NO.	STOCK NUMBER	FIG. NO.	ITEM NO.
5305-00-637-7079	61	6	5905-00-686-9998	8	43
5305-00-638-3435	61	14	5905-00-687-0000	8	20
5310-00-638-9857	20	3	5905-00-687-0000	97	15
5310-00-638-9857	21	15	5905-00-687-0000	97	24
5310-00-638-9857	23	43	5905-00-687-0002	14	7
5310-00-638-9857	27	45	5905-00-687-0002	97	20
5310-00-638-9857	30	128	5905-00-687-0002	97	24
5310-00-638-9857	40	14	5930-00-687-1079	22	7
5310-00-638-9857	41	5	5325-00-687-5208	27	15
5310-00-638-9857	58	23	5910-00-686-6881	90	21
5310-00-638-9857	59	4	5905-00-689-6799	17	25
5310-00-638-9857	74	36	5935-00-690-1742	29	4
5310-00-638-9857	96	2	5905-00-691-0195	8	13
5935-00-642-3813	37	1	5905-00-691-0195	97	26
5910-00-649-2912	90	8	5340-00-698-3440	1	57
5910-00-655-0137	97	2	5310-00-701-9130	81	19
5930-00-655-1582	96	16	5310-00-701-9130	82	11
5940-00-660-3631	58	15	5905-00-702-4439	4	4
5940-00-660-3634	59	12	5920-00-702-6694	72	9
5365-00-663-1245	30	25	5935-00-710-1717	83	3
5365-00-663-2125	98	8	3030-00-716-7893	30	100
5910-00-666-5781	27	28	5305-00-719-5064	30	146
5930-00-670-7164	77	11			
5905-00-676-7410	50	10	5305-00-719-5064	73	50
5905-00-681-6462	8	15	5305-00-719-5064	93	18
5905-00-681-6462	8	41	5305-00-719-5329	73	77
5905-00-681-6462	17	5	5305-00-719-5329	78	5
5905-00-681-6462	29	8	5305-00-719-5339	73	2
5905-00-681-6462	97	12	5305-00-719-5339	81	36
5905-00-681-8822	17	7	5935-00-721-0496	28	9
5905-00-681-9969	8	5	5935-00-721-0496	98	10
5340-00-682-1520	73	62	5905-00-721-0597	97	24
5940-00-682-2427	46	5	5305-00-721-4747	24	27
5940-00-682-2477	53	22	5365-00-721-7680	33	24
5905-00-682-4097	8	9	5365-00-721-7680	35	24
5905-00-682-4098	15	7	5310-00-722-5998	27	39
5905-00-682-4098	17	17	5310-00-722-5998	30	15
5905-00-682-4098	97	27	5905-00-723-5251	5	3
5905-00-682-4101	8	16	5905-00-723-5251	9	8
5905-00-682-4109	8	19	5905-00-723-5251	14	2
5310-00-682-5930	47	53	5905-00-723-5251	15	1
5905-00-683-2236	8	21	5905-00-723-5251	16	4
5905-00-683-2236	97	16	5905-00-723-5251	17	11
5905-00-683-2238	8	11	5905-00-723-5251	97	19
5905-00-683-2238	29	13	5935-00-725-0888	94	1
5905-00-683-2238	97	21	5905-00-726-4413	97	18
5905-00-683-2240	97	25	5935-00-726-4525	1	40
5905-00-683-2246	8	23	5935-00-726-4525	98	9
5905-00-683-2246	97	17	5905-00-726-5340	40	9
5905-00-683-2247	17	6	5935-00-727-2134	1	42
5905-00-683-7721	97	22	5905-00-727-8001	8	25
5905-00-683-7723	9	6	5305-00-727-8832	65	40
5905-00-683-7723	17	20	5905-00-727-9747	90	18
5905-00-683-7723	29	9	5905-00-727-9777	90	12
5340-00-683-9956	1	24	5905-00-731-8315	55	50
5340-00-684-9956	22	3	5940-00-736-3719	52	13
5340-00-684-9956	64	11	5940-00-736-3719	56	9
5310-00-685-3744	30	10	5340-00-741-8569	73	24
5310-00-685-3744	45	2	5905-00-752-3340	40	10
5310-00-685-3744	58	38	5961-00-752-5229	85	7
5310-00-685-3744	73	9	5961-00-752-5229	86	7
5310-00-685-3744	76	5	5961-00-752-5229	87	8
5310-00-685-3744	93	17	5961-00-752-5229	88	6
5330-00-686-2322	30	37	5961-00-752-5229	89	15
5905-00-686-3368	40	4	5961-00-752-5229	91	10
5905-00-686-3368	97	24	5961-00-752-5395	52	14
5905-00-686-3369	8	17	5961-00-752-6081	62	25
5905-00-686-3369	97	14	5905-00-752-7228	55	40
5905-00-686-3370	97	29	5910-00-760-0516	92	2
5905-00-686-3380	50	22	5905-00-761-1901	48	28
5905-00-686-3798	8	14	5905-00-761-1901	55	46
5905-00-686-3798	97	23	5905-00-763-6457	48	17
5905-00-686-4530	40	8	5905-00-763-6457	55	39
5365-00-686-5911	32	46	5305-00-763-6963	65	38
5365-00-686-5918	32	45	5305-00-763-6963	75	17
5365-00-686-5925	32	44	5305-00-763-6963	93	41
5365-00-686-5929	39	4	5305-00-763-7822	31	63
5305-00-686-5973	81	6	5305-00-763-7822	33	19
5905-00-686-9997	8	6	5305-00-763-7822	73	44
5905-00-686-9998	8	26	5305-00-763-7822	93	34

SECTION IV

TM 11-7440-222-40P/NAVELEX 0967-LP-324-0408/TO 31W4-2G-84
NATIONAL STOCK NUMBER INDEX

STOCK NUMBER	FIG. NO.	ITEM NO.	STOCK NUMBER	FIG. NO.	ITEM NO.
5305-00-763-7827	65	51	5905-00-801-6990	8	10
5305-00-763-7827	73	47	5310-00-803-4994	52	24
5305-00-764-0064	30	147	5310-00-803-4994	53	26
5305-00-764-0064	73	78	5310-00-803-4994	54	17
5305-00-764-0068	30	148			
5305-00-764-2966	32	34	5905-00-804-3932	65	49
5305-00-764-2966	72	27	5365-00-804-5043	45	28
5905-00-764-9870	69	11	3110-00-805-5590	45	22
5305-00-765-4257	65	62	5905-00-805-9714	29	7
5305-00-765-4352	72	1	5310-00-807-1465	65	58
5305-00-765-4352	73	37	5905-00-807-4954	8	8
5305-00-768-0336	1	70	5910-00-807-7253	62	6
5905-00-769-4147	89	20	5961-00-808-8398	88	8
5305-00-770-2533	33	1	5310-00-809-4058	47	54
5305-00-770-2533	34	1	5910-00-809-8088	41	9
5305-00-770-2533	35	1	5310-00-809-8544	47	71
5305-00-770-2533	36	1	5310-00-809-8546	47	59
5305-00-770-2533	94	8	5310-00-809-8546	54	9
5305-00-770-2533	95	3	5905-00-811-0673	40	2
5305-00-770-2579	93	42	5310-00-811-6419	65	11
5305-00-770-2580	23	52	5940-00-813-0698	1	56
5305-00-770-2580	58	29	5940-00-813-0698	23	40
			5940-00-813-0698	78	7
5910-00-771-9026	17	12	5940-00-813-0698	58	17
5360-00-773-6189	27	17	5940-00-813-0698	65	36
5905-00-775-4631	88	18	5935-00-813-1782	28	8
5310-00-775-5245	27	14	5325-00-813-2050	20	8
5910-00-779-8404	55	1	5935-00-813-8579	83	5
5930-00-781-2916	23	25	5961-00-814-0768	4	5
5930-00-781-2916	23	25	5961-00-814-0768	8	2
5905-00-781-4857	50	24	5961-00-814-0768	15	6
5905-00-781-8015	48	12	5961-00-814-0768	17	16
5905-00-781-8015	49	13	5961-00-814-0768	29	11
5310-00-782-1349	23	51	5961-00-814-0768	97	7
5310-00-782-1349	30	47	5940-00-815-2093	65	34
5310-00-782-1349	31	54	5935-00-816-8713	74	2
5310-00-782-1349	45	68	5935-00-816-8713	83	2
5310-00-782-1349	58	31	5935-00-816-8713	94	7
5310-00-782-1349	63	2	5325-00-817-1158	47	22
5310-00-782-1349	65	28	5930-00-818-7799	30	65
5310-00-782-1349	73	41	5930-00-818-7799	37	18
5310-00-782-1349	75	13	5935-00-820-2080	58	41
5310-00-782-1349	76	11	5910-00-821-4037	90	10
5910-00-782-1973	55	3	5910-00-823-1024	17	8
5340-00-782-8737	23	33	5910-00-823-1640	60	6
5340-00-782-8737	30	105	5910-00-827-1218	85	1
5905-00-786-8306	84	7	5910-00-827-1218	87	1
5905-00-786-8306	85	9	5910-00-827-1218	91	2
5905-00-786-8306	86	9	5940-00-827-2653	20	5
5910-00-787-2109	88	1	5940-00-827-2653	65	37
6105-00-789-3741	80	1	5940-00-827-2653	67	22
5962-00-791-0994	3	2	5940-00-827-2653	68	21
5962-00-791-0994	4	10	5940-00-827-2653	69	27
5962-00-791-0994	5	2	5940-00-827-2653	70	27
5962-00-791-0994	8	30	5961-00-827-4990	66	1
5962-00-791-0994	8	39	5961-00-827-4990	67	6
5962-00-791-1004	4	9	5961-00-827-4990	68	6
5962-00-791-1048	6	2	5961-00-827-4990	69	9
5962-00-791-1082	3	3	5961-00-827-4990	70	10
5962-00-791-1082	4	6	5935-00-830-6349	65	25
5962-00-791-1082	5	4	5905-00-831-6134	8	24
5962-00-791-1082	7	1	5910-00-833-6649	22	3
5962-00-791-1082	8	31	5905-00-834-2968	55	25
5962-00-791-1082	8	40	7040-00-835-1300	72	17
5962-00-791-1082	10	3	7040-00-835-1318	72	19
5962-00-791-1082	14	5	5910-00-835-2175	15	8
5962-00-791-1120	6	3	6605-00-835-5131	81	24
5962-00-791-1370	18	2	6605-00-835-5133	30	96
5962-00-791-1393	4	8	6605-00-835-5133	45	31
5962-00-791-1393	10	2	5310-00-836-3520	32	38
5962-00-791-1393	17	4	5935-00-837-1238	65	19
5940-00-793-7286	30	62	5910-00-838-1409	89	4
5940-00-793-7286	37	14	5935-00-840-7175	90	7
5940-00-793-7286	46	9	5905-00-840-7609	49	21
5905-00-800-0179	8	7	3120-00-842-1363	31	74
5905-00-801-6444	4	11	5315-00-843-7988	74	60
5905-00-801-6444	8	18	5365-00-845-0286	33	32
5905-00-801-6444	9	7	5365-00-845-0286	35	32
5905-00-801-6444	17	21	5905-00-845-4708	76	32
5905-00-801-6444	97	13	5310-00-845-5472	27	16

SECTION IV

TM 11-7440-222-40P/NAVELEX 0967-LP-324-0408/TO 31W4-2G-84
NATIONAL STOCK NUMBER INDEX

STOCK NUMBER	FIG. NO.	ITEM NO.	STOCK NUMBER	FIG. NO.	ITEM NO.
5961-00-845-6458	17	27	5905-00-904-7081	91	20
5935-00-850-0813	28	3	5915-00-905-1008	59	13
6240-00-851-4352	23	28	5961-00-905-2926	67	21
7040-00-851-5113	32	24	5961-00-905-2926	68	17
5961-00-852-5171	48	6	5961-00-905-2926	69	3
5961-00-852-5171	49	7	5961-00-905-2926	70	3
5961-00-852-5171	50	7	5935-00-905-5738	35	17
5961-00-852-5171	55	14	5935-00-905-5738	36	17
7025-00-852-6348	72	18	6605-00-908-1052	44	13
7025-00-852-6349	72	22	5961-00-909-4138	86	19
7025-00-852-6351	72	24	7040-00-911-1145	2	16
7025-00-852-6353	72	16	7040-00-911-1615	2	15
5961-00-852-7549	55	10	7040-00-911-1619	2	13
5961-00-852-7549	62	4	7040-00-911-2501	2	14
5905-00-855-2219	56	29	7040-00-911-2515	26	1
4130-00-864-0650	60	5	5935-00-913-0925	32	42
5910-00-864-8330	87	4	5930-00-913-2983	96	15
5910-00-864-8330	89	3	5961-00-917-8504	84	6
5935-00-868-4192	29	1	5961-00-917-8504	85	5
3110-00-870-6931	81	16	5961-00-917-8504	86	5
7040-00-877-7879	65	33	5961-00-917-8504	87	6
5975-00-878-5833	30	114	5961-00-917-8504	88	4
			5961-00-917-8504	89	7
5935-00-880-5441	76	9	5930-00-920-5995	23	24
5310-00-880-5976	65	16	5945-00-921-0378	65	24
5310-00-880-5976	65	43	5945-00-921-1162	65	26
5310-00-880-5976	67	20	5330-00-921-3894	30	20
5310-00-880-5976	68	20	5961-00-926-2569	17	10
5310-00-880-5976	69	25	5961-00-926-2569	97	10
5310-00-880-5976	70	25	5999-00-926-3227	65	9
5970-00-881-3556	65	48	5999-00-926-3228	65	14
5910-00-881-8268	96	8	3020-00-926-3753	30	103
5961-00-882-4566	91	9	3020-00-926-3756	31	60
5961-00-883-6064	89	6	5360-00-926-5421	31	10
7040-00-883-8168	31	3	5360-00-926-5421	31	35
5310-00-883-9385	37	6	5360-00-926-5421	33	11
5905-00-887-4738	90	3	5360-00-926-5421	34	11
5305-00-889-2999	63	13	5360-00-926-5421	35	10
5305-00-889-3001	63	11	5905-00-926-8706	90	9
5905-00-892-0349	52	15	6210-00-927-3519	23	30
5905-00-892-0349	55	38	6210-00-927-3688	23	30
5961-00-892-1009	48	3	5310-00-928-2690	27	T
7025-00-895-3964	44	6	5310-00-928-2690	32	19
7040-00-895-3973	39	8	5310-00-928-2690	72	26
7040-00-895-3976	30	27	5310-00-928-2690	74	72
7040-00-895-3982	30	2	5945-00-928-8231	30	121
7040-00-895-3982	30	57	5961-00-929-2561	90	2
			5935-00-929-3118	30	117
7040-00-895-3992	31	39	5961-00-929-4947	89	8
7040-00-895-3994	30	94	5910-00-929-5008	65	4
7040-00-895-3995	30	26	5310-00-929-6395	20	4
7025-00-895-4024	31	18	5310-00-929-6395	21	16
7025-00-895-4044	32	57	5310-00-929-6395	23	44
7025-00-895-4053	32	25	5310-00-929-6395	27	9
7025-00-895-4092	32	43	5310-00-929-6395	47	75
7040-00-898-7020	32	49	5310-00-929-6395	52	19
7040-00-898-7021	30	22	5310-00-929-6395	54	2
7040-00-898-7026	39	2	5310-00-929-6395	55	59
7040-00-898-7036	30	152	5310-00-929-6395	58	11
7040-00-898-7103	32	50	5310-00-929-6395	58	24
7040-00-898-7160	32	26	5310-00-929-6395	59	5
			5310-00-929-6395	61	9
6680-00-898-7211	30	39	5310-00-929-6395	63	6
5905-00-899-4081	27	36	5310-00-929-6395	65	42
5910-00-899-4395	14	8	5310-00-929-6395	67	19
5910-00-899-4395	97	4	5310-00-929-6395	66	19
5910-00-899-9129	18	3	5310-00-929-6395	69	24
5910-00-899-9129	97	3	5310-00-929-6395	70	24
5905-00-900-2051	90	5	5310-00-929-6395	72	4
5961-00-901-4862	84	1	5310-00-929-6395	73	19
5961-00-901-4862	85	6	5310-00-929-6395	74	24
5961-00-901-4862	86	6	5310-00-929-6395	75	2
5961-00-901-4862	87	7	5310-00-929-6395	93	4
5961-00-901-4862	91	8	5310-00-929-6395	96	9
5961-00-901-1586	55	9	5910-00-929-7850	69	10
5920-00-901-9936	72	8	5930-00-929-7869	30	76
5905-00-902-1229	27	35	5930-00-929-7869	45	15
5905-00-902-7456	52	3	5945-00-929-7871	65	31
5905-00-902-7456	53	1	5961-00-931-0372	62	5
5905-00-904-7081	86	15	5961-00-931-0385	67	4

SECTION IV

NATIONAL STOCK NUMBER INDEX

STOCK NUMBER	FIG. NO.	ITEM NO.	STOCK NUMBER	FIG. NO.	ITEM NO.
5961-00-931-0385	68	4	5310-00-934-9761	67	17
5961-00-931-0385	69	16	5310-00-934-9761	68	24
5961-00-931-0385	70	8	5310-00-934-9761	69	22
5935-00-931-0386	30	64	5310-00-934-9761	70	22
5930-00-931-0514	22	8	5310-00-934-9761	72	3
7025-00-931-4748	31	46	5310-00-934-9761	73	18
3120-00-931-8695	81	18	5310-00-934-9761	93	10
5310-00-934-9761	96	10			
5930-00-932-3586	32	17	5310-00-934-9765	1	60
5999-00-933-5070	1	44	5310-00-934-9765	21	7
5999-00-933-5070	1	45	5310-00-934-9765	23	34
5999-00-933-5070	23	32	5310-00-934-9765	24	26
5999-00-933-5070	58	21	5310-00-934-9765	26	9
5310-00-933-8118	23	50	5310-00-934-9765	64	4
5310-00-933-8118	27	31	5961-00-935-0138	53	13
5310-00-933-8118	30	52	5999-00-935-2377	2	2
5310-00-933-8118	31	5	5999-00-935-2378	2	9
5310-00-933-8118	31	26	5999-00-935-2379	2	17
5310-00-933-8118	32	3	5999-00-935-2380	2	18
5310-00-933-8118	37	11	5999-00-935-2381	2	5
5310-00-933-8118	58	30	5999-00-935-2382	2	4
5310-00-933-8118	63	3	5999-00-935-2383	2	12
5310-00-933-8118	65	27	5999-00-935-2384	2	3
5310-00-933-8118	69	5	5999-00-935-2385	2	10
5310-00-933-8118	70	5	5999-00-935-2386	2	11
5310-00-933-8118	73	40	5999-00-935-2387	2	7
5310-00-933-8118	73	69	5999-00-935-2388	2	6
5310-00-933-8118	76	16	5940-00-935-8246	52	2
5310-00-933-8118	93	21	5940-00-935-8246	53	4
5310-00-933-8119	1	14	5940-00-935-8246	54	8
5310-00-933-8119	21	2	5940-00-935-8248	52	21
5310-00-933-8119	25	3	5940-00-935-8248	53	24
5310-00-933-8119	26	5	5940-00-935-8248	54	15
5310-00-933-8119	27	43	5940-00-935-8256	47	11
5310-00-933-8119	58	3	3120-00-936-5450	30	102
5310-00-933-8119	58	39	7440-00-937-3204	72	20
5310-00-933-8119	59	16	5315-00-937-9653	31	67
5310-00-933-8119	60	4	5315-00-937-9653	81	27
5310-00-933-8119	65	46	5961-00-938-1135	55	8
5310-00-933-8119	73	8	5310-00-938-2013	27	8
5310-00-933-8119	76	6	5310-00-938-2013	74	26
5310-00-933-8119	79	6	5310-00-938-2013	74	35
5310-00-933-8119	93	16	5310-00-938-2013	77	15
5310-00-933-8119	96	12	5905-00-940-2751	89	28
5310-00-933-8120	1	20	5935-00-940-3119	65	23
5310-00-933-8120	19	3	6605-00-941-0561	23	23
5310-00-933-8120	21	10	5999-00-946-0947	8	33
5310-00-933-8120	23	35	5999-00-946-0947	17	28
5310-00-933-8120	24	24	5999-00-946-0947	29	18
5310-00-933-8120	26	10	5999-00-946-0947	68	13
5310-00-933-8120	27	1	5999-00-946-0947	69	19
5310-00-933-8120	64	3	5999-00-946-0947	97	36
5310-00-933-8120	71	4	5961-00-949-1432	8	42
5310-00-933-8120	73	12	5961-00-949-1432	29	12
5310-00-933-8121	59	21	5961-00-949-1432	97	9
5310-00-933-8121	73	5	5961-00-949-1440	29	10
5310-00-933-8121	79	8	5961-00-949-1440	50	8
5310-00-934-9747	47	30	5961-00-949-1440	55	15
5310-00-934-9748	1	65	5930-00-951-6451	32	18
5310-00-934-9748	65	30	5905-00-951-6735	89	27
5310-00-934-9759	1	54	5905-00-951-8105	98	17
5310-00-934-9759	21	4	5905-00-952-2146	50	28
5310-00-934-9759	26	7	5905-00-952-2148	50	12
5310-00-934-9759	58	5	5920-00-952-5360	57	5
5310-00-934-9759	58	37	5905-00-952-6023	50	25
5310-00-934-9759	59	17	5905-00-952-6024	55	51
5310-00-934-9759	65	45	5905-00-952-7042	48	21
5310-00-934-9759	93	32	5905-00-952-9230	49	18
5310-00-934-9759	96	11	5905-00-954-4642	48	27
5310-00-934-9761	21	17	5905-00-954-4642	49	20
5310-00-934-9761	27	10	5905-00-954-4642	55	29
5310-00-934-9761	53	18	5910-00-954-7368	97	6
5310-00-934-9761	55	57	5905-00-957-0642	88	19
5310-00-934-9761	58	12	5905-00-957-0643	48	25
5310-00-934-9761	59	6	5905-00-957-0643	49	9
5310-00-934-9761	61	8	5305-00-958-6511	74	53
5310-00-934-9761	62	16	5305-00-959-0379	30	53
5310-00-934-9761	63	5	5305-00-959-0379	32	4
5310-00-934-9761	69	18	5305-00-959-0382	32	40
5310-00-934-9761	65	41	5305-00-959-0382	35	19

SECTION IV

**TM 11-7440-222-40P/NAVELEX 0967-LP-324-0408/TO 31W4-2G-84
NATIONAL STOCK NUMBER INDEX**

STOCK NUMBER	FIG. NO.	ITEM NO.	STOCK NUMBER	FIG. NO.	ITEM NO.
5305-00-959-0382	74	34	5905-00-985-4889	48	20
5305-00-959-0382	82	7	5905-00-985-4889	88	20
5305-00-959-1082	32	37	5905-00-985-5435	49	16
5305-00-959-1082	74	97	5905-00-985-5464	88	10
5305-00-959-1082	75	15	6605-00-987-1679	31	69
5305-00-959-1909	73	35	3020-00-987-7682	82	15
6150-00-959-2776	27	24	3020-00-987-7683	82	16
5930-00-959-3427	23	24	6605-00-987-7693	81	21
5821-00-961-3243	47	25	5905-00-988-2306	88	13
5905-00-965-5554	48	29	5905-00-988-2313	48	23
5920-00-968-3238	27	20	5905-00-988-2313	55	49
5920-00-968-3238	73	38	5905-00-988-2317	48	26
5905-00-969-5851	17	22	5305-00-988-7602	31	80
5905-00-969-5854	50	13	5305-00-988-7603	30	9
5340-00-969-6501	23	37	5305-00-988-7603	79	7
5340-00-969-6501	84	11	5305-00-988-7604	73	25
5340-00-969-6501	85	21	5305-00-988-7605	74	88
5340-00-969-6501	86	21	5305-00-988-7605	93	30
5340-00-969-6501	87	23	5305-00-988-7614	73	80
5340-00-969-6501	88	27	7440-00-989-3605	32	6
5340-00-969-6501	89	35	6685-00-989-3615	30	51
5340-00-969-6501	90	14	7040-00-989-3618	73	58
5340-00-969-6501	91	26	7040-00-989-3621	31	23
5340-00-969-6501	92	15	7040-00-989-3623	39	1
5365-00-971-6201	31	8	7025-00-989-3625	31	52
5365-00-971-6201	31	38	1040-00-989-3627	39	9
5365-00-971-6201	82	28	7035-00-989-3628	41	11
5340-00-971-7610	33	12	5970-00-989-8333	84	8
5340-00-971-7610	34	12	5970-00-989-8333	85	20
5340-00-971-7610	35	11	5970-00-989-8333	86	20
5340-00-971-7610	36	11	5970-00-989-8333	87	22
5961-00-972-0046	89	9	5940-00-990-1658	84	10
5935-00-973-7852	37	3	5940-00-990-1658	85	17
5905-00-975-1131	88	9	5940-00-990-1658	86	17
3110-00-975-2051	74	75	5940-00-990-1658	87	19
5905-00-978-7703	56	33	5940-00-990-1658	88	21
5365-00-980-8163	32	48	5940-00-990-1658	89	29
5999-00-982-0036	30	133	5940-00-990-1658	90	13
5310-00-982-6813	1	19	5940-00-990-1658	91	23
5940-00-983-6046	46	1	5330-00-990-2869	32	30
5940-00-983-6047	30	143	5305-00-990-6381	73	36
5305-00-983-6654	30	111	5940-00-993-5216	58	28
5905-00-983-6914	55	34	5961-00-995-2310	8	28
5905-00-983-6914	88	12	5961-00-995-2310	97	30
5310-00-983-8483	47	38	5920-00-995-6079	27	22
5310-00-983-8483	51	5	5905-00-995-7945	29	16
5310-00-983-8483	52	12	5910-00-995-9189	26	15
5310-00-983-8483	53	6	7040-00-997-6207	30	43
5310-00-983-8483	54	3	7035-00-997-6212	31	73
5905-00-984-1465	49	15	5340-00-997-6221	32	5
5905-00-984-1465	55	24	5961-00-999-7351	54	12
5905-00-984-1465	88	11	5970-01-035-2869	96	19
5305-00-984-7361	24	2			
5340-00-984-8854	64	10			

PART NUMBER	FSCM	FIG. NO.	ITEM NO.	PART NUMBER	FSCM	FIG. NO.	ITEM NO.
A-534-06	98410	61	19	AN960C10L	88044	23	36
AA-8140	98410	61	20	AN960C10L	88044	26	11
AFH2-06-20	00656	41	9	N960CO11L	88044	30	109
AN3420-10	88044	98	8	AN960C10L	88044	64	8
AN3420-8	88044	98	7	AN960C10L	88044	71	3
AN365C632	88044	31	14	AN960C16L	88044	46	11
AN365C632	88044	31	33	AN960C2	88044	77	13
AN365C632	88044	33	13	AN960C2L	88044	27	6
AN365C632	88044	34	13	AN960C2L	88044	37	16
AN365C632	88044	35	13	AN960C2L	88044	72	28
AN365C632	88044	36	13	AN960C4	88044	23	51
AN365C632	88044	82	23	AN960C4	88044	30	47
AN505P6RS	88044	47	61	AN960C4	88044	31	54
				AN960C4	88044	45	68
AN96C6L	88044	27	34	AN960C4	88044	58	31
AN960C10	88044	24	23	AN960C4	88044	63	2
AN960C01	88044	73	13	AN960C4	88044	73	41
AN960C10	88044	74	8	AN960C4	88044	75	13
AN960C10L	88044	1	21	AN960C4	88044	76	11
AN960C10L	88044	19	4	AN960C4L	88044	1	66
AN960C10L	88044	21	9	AN960C4L	88044	27	30

SECTION IV

NATIONAL STOCK NUMBER AND PART NUMBER INDEX

PART NUMBER	FSCM	FIG. NO.	ITEM NO.	PART NUMBER	FSCM	FIG. NO.	ITEM NO.
AN960C4L	88044	30	136	A53909-001	58189	1	27
AN960C416	85044	22	4	A61665-001	58189	1	29
AN960C416	88044	64	12	A61665-002	58189	58	18
AN960C416L	88044	30	97	A61706-005	58189	21	13
AN960C5	88044	77	3	A61707-003	58189	2	1
AN960C6	88044	47	77	A64008-001	58189	1	34
AN960C6	88044	30	5	A64041-001	58189	59	Z
AN960C6	88044	30	140	A64504-001	58189	1	3
AN960C6	88044	32	12	A64504-002	58189	2	8
AN960C6	88044	37	7	A64504-003	58189	19	6
AN960C6	88044	45	7	A64504-004	58189	19	1
AN960C6	88044	46	2	A64504-005	58189	19	10
AN960C6	88044	61	5	A64505-001	58189	1	2
AN960C6	88044	63	7	A64509-001	12436	1	1
AN960C6	88044	72	5	A64511-001	58189	25	6
AN960C6	88044	73	26	A64514-001	58189	22	1
AN960C6	88044	74	50	A64518-001	58189	23	18
AN960C6	88044	93	11	A64522-001	58189	26	3
AN960C6L	88044	20	3	A64524-002	58189	26	17
AN960C6L	88044	21	15	A64526-001	58189	26	2
AN960C6L	88044	23	43	A64528-002	58189	27	4
AN960CbL	88044	27	45	A64530-001	58189	27	19
AN960C6L	88044	30	128	A64531-001	58189	27	44
AN960C6L	88044	40	14	A64533-001	58189	20	9
AN960C6L	88044	41	5	A64538-001	58189	1	8
AN960C6L	88044	58	23	A64539-001	58189	64	5
AN960C6L	88044	59	4	A64543-001	58189	1	23
AN960C6L	88044	74	36	A64548-001	58189	1	15
AN960C6L	88044	96	2	A64550-001	58189	1	25
AN960C8	88044	30	10	A65132-002	58189	59	9
AN960C8	88044	45	2	A65201-001	12436	2	7
AN960C8	88044	58	38	A65202-001	58189	8	32
AN960C8	88044	73	9	A65219-001	58189	2	7
AN960C8	88044	76	5	A65220-001	58189	8	34
AN960C8	88044	93	17	A65361-001	12436	2	4
AN960CL	88044	1	13	A65362-001	58189	9	1
AN960C8L	88044	21	3	A65365-001	12436	2	3
AN960C8L	88044	25	4	A65366-001	58189	10	1
AN960C8L	88044	26	6	A65369-001	12436	2	2
AN960C8L	88044	27	42	A65370-001	58189	17	1
AN960C8L	88044	58	4	A65373-001	12436	2	17
AN960C8L	88044	59	15	A65374-001	58189	12	1
AN960C8L	88044	60	3	A65377-001	12436	2	9
AN960C8L	88044	73	46	A65378-001	58189	13	1
AN960C8L	88044	96	13	A65385-001	12436	2	10
AN961-10	88044	47	49	A65386-001	58189	14	1
AS632-2	46384	47	65	A65389-001	12436	2	11
A1-10977F-4	14850	93	45	A65390-001	58189	15	2
A1-10977F-5	14850	47	8	A65393-001	12436	2	5
A1-10977F-6	14850	1	36	A65394-001	58189	16	1
A1-10979C	14850	1	37	A65397-001	12436	2	6
A1-10980C	14850	47	9	A65398-001	58189	17	1
A1-118648	14850	93	43	A65405-001	58189	58	20
A10042	07047	84	8	A65406-001	58189	22	9
A10042	07047	85	20	A65407-001	58189	27	12
A10042	07047	86	20	A65409-001	58189	1	48
A10042	07047	87	22	A65411-001	58189	23	22
A148X280	03508	48	4	A65413-001	58189	1	46
A148X280	03508	49	3	A65415-001	58189	1	47
A14BX280	03508	50	3	A65441-001	12436	2	13
A2389-20-1-0	16512	95	5	A65442-001	58189	4	1
A240	57771	56	14	BB523-06	98410	30	90
A510	57771	47	22	BB523-06	98410	30	119
A53418-001	12436	2	14	BB523-06	98410	30	144
A53419-001	58189	3	1	BB523-06	98410	46	6
A53506-001	12436	26	1	6P4	37942	41	10
A53507-001	58189	29	17	81-16X1-4SS	83584	74	17
A53584-001	12436	2	12	8126-2870	55938	65	1
A53585-001	58189	5	1	8126-2871	55938	65	5
A53721-001	12436	2	16	824-2	71041	31	74
A53722-001	58189	6	1	83263A	13327	69	26
A53725-001	12436	2	15	83263A	13327	70	76
A53726-001	58189	7	2	86509207-1	16554	74	58
A53846-001	58189	23	55	86509207-2	16554	74	61
A53846-001	58189	58	35	CA06R22-14S	71468	1	40
A53847-001	58189	1	44	CA06R22-14S	71468	98	9
A53847-001	58189	1	45	CA06R24-28S	71468	1	41
A53847-001	58189	23	32	CA06R28-12S	71468	1	42
A53847-001	58189	58	21	CA06R28-20S	71468	1	38
A53855-001	58189	20	14	CK06BX104N	81349	14	6

SECTION IV

NATIONAL STOCK NUMBER AND PART NUMBER INDEX

PART NUMBER	FSCM	FIG. NO.	ITEM NO.	PART NUMBER	FSCM	FIG. NO.	ITEM NO.
CLS632-3	46384	52	24	C20-562G	16299	92	9
CLS632-3	46384	53	26	C20-562G	16299	84	12
CLS632-3	46384	54	17	C20-562G	16299	85	12
				C20-562G	16299	87	14
CL65BG181MP3	81349	55	6	C20-682G	07115	86	11
CM05F161J03	81349	8	1	C20-682G	07115	87	13
CM05F241J03	81349	97	6	C20-682G	07115	91	14
CM05F391J03	81349	97	5	C20-682G	07115	85	11
				C20-822G	07115	89	19
				C20-911G	16299	84	5
				C230622	88813	1	30
				C240-026-0440	70472	73	52
				C29943-014-1	78553	24	31
CM06F821J03	81349	4	2	C300-026-1000S	92830	76	10
				C300S14	06666	1	33
				C300S14L	06666	26	13
				C300S14RTB	06666	26	8
				C300S24	06666	64	6
CPC1953-12B	76116	1	72	C300S24	06666	19	7
CPC1953-16B	71616	1	68	C7088K	18324	4	7
CPC1953-2A	71616	1	73	C7088K	18324	5	5
CPC1953-4A	71616	23	33	C7088K	18324	16	6
CPC1953-7B	71616	23	37	C7088K	18324	9	5
CP09A1KB103K3	81349	15	8	C7088K	18324	10	4
CP09A1KB104K3	81349	14	8	C7088K	18324	11	5
CP09A1KB104K3	81349	97	4	C1088K	18324	12	5
CP09A1K8154K3	81349	17	8	C7088K	18324	13	4
CP09A1KB473K3	81349	97	2	C7088K	18324	14	3
CP09A1KF474K3	81349	96	8	C7088K	18324	15	5
CR120G900A02	02295	55	12	C7088K	18324	17	15
				C7088K	18324	4	9
CS138C227M	81349	17	18	C7089K	18324	3	3
CS138D106K	81349	91	5	C7090K	18324	4	6
				C7090K	18324	5	4
CS138D686M	81349	18	3	C7090K	18324	7	1
CS138D686M	81349	97	3	C7090K	18324	8	31
CS13BE106K	81349	55	3	C7090K	18324	8	40
CS13BE107K	81349	55	1	C7090K	18324	10	3
CS13BE107N	81349	17	2	C7090K	18324	14	5
CS13BF1O5K	81349	88	1	C7090K	18324	9	4
CS13BF334N	81349	15	11	C7090K	18324	11	3
				C7090K	18324	12	3
C1-8X1-4SS	83584	74	86	C7090K	18324	13	3
C1663-017-24	88813	1	18	C7090K	18324	15	3
C20-100J	88813	90	20	C7090K	18324	16	3
C20-102G	16299	86	15	C7090K	18324	17	14
C20-102GC	16299	91	20	C7091K	18324	4	8
C20-102G	16299	85	15	C7091K	18324	10	2
C20-102G	16299	87	17	C7091K	18324	17	4
C20-103G	16299	91	21	C7091K	18324	11	2
C20-103G	16299	89	16	C7091K	18324	14	9
C20-122G	88813	84	4	C7091K	18324	15	10
C20-152G	07115	89	17	C7577K	18324	6	2
C20-153G	07115	86	16	C7577K	18324	9	2
C20-153G	07115	89	22	C7579K	18324	6	3
C20-153G	07115	91	22	C7579K	18324	9	3
CZ0-153G	07115	92	11	C7579K	18324	12	4
C20-153G	07115	85	16	C7579K	18324	3	2
C20-1536	07115	87	18	C7580K	18324	4	10
C20-222G	07115	86	14	C7580K	18324	5	2
C20-222G	07115	87	16	C7580K	18324	8	30
C20-222G	07115	89	21	C7580K	18324	8	39
C20-222G	07115	91	18	C7580K	18324	10	5
C20-222G	07115	92	10	C7580K	18324	11	4
C20-222G	07115	85	14	C7580K	18324	12	2
C20-242G	07115	86	13	C7580K	18324	13	2
C20-242G	07115	91	19	C7580K	18324	14	4
C20-242G	07115	92	8	C7580K	18324	15	4
C20-242G	07115	85	13	C7580K	18324	74	1
C20-242G	07115	87	15	DEM9P	71468	76	9
C20-243G	07115	91	16	DEM9P	71468		
C20-272G	16299	84	3				
C20-301G	07115	89	24				
C20-302G	07115	91	15				
C20-302G	07115	89	23				
C20-473G	07115	86	10	DE9P	71468	83	3
C20-473G	07115	87	12	DE9S	71468	94	3
C20-473G	07115	91	13	DE9S	11468	95	4
C20-473G	07115	85	10	DHD572	03508	89	9
C20-562G	16299	86	12	DM103SL	08289	53	15
C20-562G	16299	89	26	DM103SL	08289	55	56

SECTION IV

NATIONAL STOCK NUMBER AND PART NUMBER INDEX

PART NUMBER	FSCM	FIG. NO.	ITEM NO.	PART NUMBER	FSCM	FIG. NO.	ITEM NO.
DN15-470J	72136	90	8	JAN2N491A	81349	17	10
DPP11A	77342	93	2	JAN2N491A	81349	97	10
DS13BE106M	81349	97	1	JF2S	81312	83	5
D1-10981C	14850	47	29	JS220	91929	77	11
D1-10982B	14850	93	44	JS261	91929	30	76
D1-10984B-1	14850	47	10	JS261	91929	45	15
D1-10985B1	14850	1	35	J302-6800	76487	89	11
D1-10987C	14850	47	31	LC002D3	84830	45	65
D1-8X1-4SS	83584	73	53	LC022C3	84830	32	2
D1-8X3-SS	83584	76	22	L1M300	27014	90	6
E82R75	01121	87	11	MOAIOA250V	71400	57	12
E82R75	01121	91	11	MS15036-149	96906	98	5
EB2R75	01121	92	6	MS102R24-28P	96906	94	10
EP34PJ	10400	30	117	MS15795-205	96906	51	5
F835-2	71041	74	68	MS15795-205	96906	52	12
FHL18G1-1	71400	57	5	MS15795-205	96906	53	6
FHL18G1-5	71400	57	10	MS15795-205	96906	54	3
FHL18G1-9	71400	57	13	MS15795-208	96906	54	9
FR33NM	83086	74	79	MS515795-303	96906	32	31
FTSM6614	98291	52	21	MS15795-803	96906	32	8
FTSM6614	98291	53	24	MS15795-804	96906	65	28
FTSM6614	98291	54	15	MS15795-805	96906	22	39
FTSM6614	98291	56	16	MS15795-805	96906	30	15
F03A250V10A	81349	57	4	MS15795-806	96906	65	16
F03A250V15A	81349	57	8	MS15795-806	96906	65	43
G87200-4	24211	96	5	MS15795-806	96906	67	20
GMT1	71400	72	8	MS15795-806	96906	68	20
GMT1-2	71400	27	22	MS15795-806	96906	69	25
GMT1-4	71400	72	9	MS15795-806	96906	70	25
GMT18-100	71400	27	23	MS15795-808	96906	29	71
GTR502	03508	89	12	MS15795-809	96906	45	11
G1032	00613	65	15	MS15795-841	96906	65	35
G51PB	03296	93	14	MS16632-4031	96906	33	32
HKL-X	71400	57	11	MS16632-4031	96906	35	32
HKP-A	71400	57	6	MS16995-10	96906	30	53
HLT	71400	27	20	MS16995-10	96906	32	4
HLT	71400	73	38	MS16995-11	96906	31	50
HP-12N	09922	1	63	MS16995-11	96906	32	11
HP-12N	09922	96	17	MS16995-11	96906	73	65
HP-16N	09922	1	57	MS16995-11	96906	76	31
HP-4N	09922	1	69	MS16995-11	96906	83	4
HP-4N	09922	52	9	MS16995-11	96906	88	24
HP-4N	09922	53	11	MS16995-11	96906	89	31
HP-4N	09922	54	7	MS16995-16	96906	33	7
HP-4N	09922	90	17	MS16995-16	96906	34	7
HP-SN	12357	1	55	MS16995-16	96906	35	6
HP-8N	12357	1	59	MS16995-16	96906	36	6
HP-9N	09922	1	53	MS16995-17	96906	32	40
HP10N	09922	1	51	MS16995-17	96906	35	19
HP10N	09922	1	62	MS16995-17	96906	74	34
HP10N	09922	27	40	MS16995-17	96906	82	7
HP13N	09922	1	49	MS16995-18	96906	32	37
HP13N	09922	58	13	MS16995-18	96906	74	97
HP18N	09922	58	7	MS16995-18	96906	75	15
HP10N	09922	96	14	MS16995-19	96906	73	36
HP7N	09922	23	48	MS16995-2	96906	74	73
JA-L-WCG-JHP	74193	61	18	MS16995-26	96906	31	80
JAN1N3064	81349	4	5	MS16995-27	96906	30	9
JAN1N3064	81349	8	2	MS16995-27	96906	79	7
JAN1N3064	81349	15	6	MS16995-28	96906	73	25
JAN1N3064	81349	17	16	MS16995-29	96906	74	88
JAN1N3064	81349	29	11	MS16995-29	96906	93	30
JAN1N3064	81349	97	7	MS16995-50	96906	73	80
JAN1N3666-2	81349	17	26	MS16995-9	96906	30	55
MS16995-9	96906	76	1Z				
JAN1N3828A	81349	8	29	MS16996-10	96906	73	11
JAN1N752A	81349	8	28	MS16996-10	96906	74	33
JAN1NS72A	81349	97	30	MS16996-11	96906	73	35
JAN1N756A	81349	17	27	MS16996-12	96906	74	53
JAN2N104	81349	97	11	MS16998-31	96906	30	111
MS17122-6	96906	84	10				
JAN2N11485	81349	98	15	MS17122-6	96906	85	17
JAN2N2219	81349	8	3	MS17122-6	96906	86	17
JAN2N2219	81349	8	42	MS17122-6	96906	87	19
JAN2N2219	81349	17	9	MS17122-6	96906	88	21
JAN2N2219	81349	29	12	MS17122-6	96906	89	29
MS17122-6	96906	90	13				
JAR2N2219	81349	97	9	MS17122-6	96906	91	23
JAN2N2905A	81349	8	4	MS17160-30	96906	96	20
JAN2N2905A	81349	29	10	MS17821-1-9	96906	23	53

SECTION IV

NATIONAL STOCK NUMBER AND PART NUMBER INDEX

PART NUMBER	FSCM	FIG. NO.	ITEM NO.	PART NUMBER	FSCM	FIG. NO.	ITEM NO.
MS17821-1-9	96906	28	1	MS35335-59	96906	76	3
MS17821-1-9	96906	58	33	MS35335-59	96906	93	19
MS1B212-30	96906	20	16	MS35335-60	96906	93	39
MS20073-60	96906	47	58	MS35335-61	96906	59	22
MS20341-108	96906	47	51				
MS21042-04	96906	65	11				
MS21042-06	96906	65	58	MS35337-22	96906	53	7
MS21044C06	96906	1	19	MS35337-41	96906	51	6
MS21318-1	96906	1	26	MS35337-41	96906	5	18
MS21919DG23	96906	30	125	MS35337-79	96906	52	19
MS24417-1	96906	22	7	MS35337-79	96906	54	2
MS24618-40	96906	24	27	MS35338-134	96906	27	7
MS25035-54	96906	59	7	MS35338-134	96906	32	19
MS25036-1	96906	1	56	MS35338-134	96906	72	26
MS25036-1	96906	23	40	MS35338-134	96906	14	72
MS25036-1	96906	28	7	MS35338-135	96906	23	50
MS25036-1	96906	58	17	MS35338-135	96906	27	31
MS25036-101	96906	65	36	MS35338-135	96906	30	52
MS2525036-102	96906	98	4	MS35338-135	96906	31	5
MS25036-103	96906	98	12	MS35338-135	96906	31	26
MS25036-12	96906	22	10	MS35338-135	96906	32	3
MS25036-12	96906	28	5	MS35338-135	96906	37	11
MS25036-12	96906	58	42	MS35338-135	96906	58	30
MS25036-16	96906	58	16	MS35338-135	96906	63	3
MS2525036-3	96906	23	39	MS35338-135	96906	65	27
MS25036-3	96906	28	6	MS35338-135	96906	69	5
MS25036-3	96906	58	36	MS35338-135	96906	70	5
MS2525036-49	96906	58	44	MS35338-135	96906	73	40
MS25036-50	96906	58	15	MS35338-135	96906	73	69
MS55036-53	96906	58	43	MS35338-135	96906	76	16
MS25036-53	96906	59	8	MS35338-135	96906	93	21
MS25036-56	96906	59	19	MS35338-136	96906	20	4
MS25036-57	96906	59	12	MS35338-136	96906	21	16
MS25036-6	96906	23	38	MS35338-136	96906	23	44
MS527183-10	96906	47	54	MS35338-136	96906	27	9
MSZ7183-5	96906	47	38	MS35336-136	96906	47	75
MS27183-6	96906	47	16	MS35338-136	96906	55	5'
MS27183-6	96906	56	19	MS35338-136	96906	58	11
MS27183-7	96906	47	71	MS35338-136	96906	58	24
MS27183-8	96906	47	59	MS35338-136	96906	59	5
MS3102R22-14P	96906	28	9	MS35338-136	96906	61	9
MS3102R22-14P	96906	98	10	MS35338-136	96906	63	6
MS3102R28-12P	96906	94	1	MS35338-136	96906	65	42
MS3102R28-12PW	96906	65	19	MS35338-136	96906	67	19
MS3102R28-20P	96906	28	8	MS35338-136	96906	68	19
MS3102R32-75	96906	58	41	MS35338-136	96906	69	24
MS35059-23	96906	96	16	MS35338-136	96906	70	24
MS35191-70	96906	24	2	MS35338-136	96906	72	4
MS35223-17	96906	63	13	MS35338-136	96906	73	19
MS35223-25	96906	61	14	MS35338-136	96906	74	24
MS35223-26	96906	61	6	MS35338-136	96906	71	2
MS35223-28	96906	62	14	MS35338-136	96906	93	4
MS35223-31	96906	63	11	MS35338-136	96906	96	9
MS35333-69	96906	37	17	MS35338-137	96906	1	14
MS35333-69	96906	45	13	MS35338-137	96906	21	2
MS35333-70	96906	30	49	MS35338-137	96906	25	3
MS35333-70	96906	31	49	MS35338-137	96906	26	5
MS35333-70	96906	32	10	MS35338-137	96906	27	43
				MS35338-137	96906	58	3
MS35333-71	96906	30	6	MS35338-137	96906	58	39
MS35333-71	96906	30	16	MS35338-137	96906	59	16
MS35333-71	96906	32	36	MS35338-137	96906	60	4
MS35333-71	96906	33	5	MS35338-137	96906	65	46
MS35333-71	96906	33	20	MS35338-137	96906	73	8
MS35333-71	96906	34	5	MS35338-137	96906	76	6
MS35333-71	96906	35	5	MS35338-137	96906	79	6
MS35333-71	96906	35	20	MS35338-137	96906	93	16
MS35333-71	96906	36	5	MS35338-137	96906	96	12
M535333-71	96906	40	13	MS35338-138	96906	1	20
MS35333-71	96906	41	2	MS35338-138	96906	19	3
MS35333-71	96906	45	8	MS35338-138	96906	21	to
MS35333-71	96906	46	3	MS35338-138	96906	23	35
MS35333-71	96906	62	15	MS35338-138	96906	24	24
MS35333-71	96906	81	10	MS35338-138	96906	26	10
MS35333-72	96906	30	8	MS35338-138	96906	27	1
MS35333-72	96906	45	3	MS35338-138	96906	64	3
MS35333-73	96906	30	110	MS35338-138	96906	71	4
MS35335-58	96906	30	149	MS35338-138	96906	73	12
MS35335-58	96906	73	33	MS35338-139	96906	59	21
MS35335-59	96906	1	52	MS35338-139	96906	13	5

SECTION IV

NATIONAL STOCK NUMBER AND PART NUMBER INDEX

PART NUMBER	FSCM	FIG. NO.	ITEM NO.	PART NUMBER	FSCM	FIG. NO.	ITEM NO.
MS35338-139	96906	79	8	MS51957-13	96906	70	4
MS35338-155	96906	37	6	MS51957-14	96906	31	51
MS35338-40	96906	38	2	MS51957-14	96906	37	10
MS35338-40	96906	47	39	MS51957-14	96906	47	37
MS35338-41	96906	47	17	MS51957-14	96906	81	11
MS35338-42	96906	47	70	MS51957-15	96906	27	29
MS35338-43	96906	41	60	MS51957-15	96906	30	139
MS35338-81	96906	29	20	MS51957-15	96906	65	29
MS35339-44	96906	47	53	MS51957-15	96906	73	70
MS35490-32	96906	20	8	MS51957-15	96906	74	51
MS35649-144	96906	23	49	MS51957-15	96906	75	10
MS35649-144	96906	27	32	MS51957-15	96906	76	15
MS35649-224	96906	27	8	MS51957-17	96906	1	67
MS35649-224	96906	77	15	MS51957-17	96906	27	37
MS35649-24	96906	74	26	MS51957-17	96906	47	4
MS35649-24	96906	74	35	MS51957-17	96906	74	9
MS35649-244	96906	1	65	MS51957-18	96906	27	21
MS35649-244	96906	65	30	MS51957-18	96906	30	127
MS35649-262	96906	47	30	MS51957-18	96906	65	10
MS35649-264	96906	21	17	MS51957-20	96906	93	26
MS35649-264	96906	27	10	MS51957-26	96906	32	59
MS35649-264	96906	53	18	MS51957-26	96906	40	15
MS35649-264	96906	55	57	MS51957-26	96906	45	6
MS35649-264	96906	58	12	MS51957-26	96906	46	16
MS35649-264	96906	59	6	MS51957-26	96906	72	10
MS35649-264	96906	61	8	MS51957-26	96906	73	32
MS35649-264	96906	62	16	MS51957-26	96906	81	9
MS35649-264	96906	63	5	MS51957-26	96906	96	22
MS35649-264	96906	65	18	MS51957-27	96906	20	7
MS35649-264	96906	65	41	MS51957-27	96906	30	120
MS35649-264	96906	67	17	MS51957-27	96906	37	21
MS35649-264	96906	68	24	MS51957-27	96906	47	76
MS35649-264	96906	69	22	MS51957-28	96906	20	2
MS35649-264	96906	70	22	MS51957-28	96906	27	46
MS35649-264	96906	72	3	MS51957-28	96906	30	141
MS35649-264	96906	73	18	MS51957-28	96906	31	19
MS35649-264	96906	93	10	MS51957-28	96906	41	4
MS35649-264	96906	96	10	MS51957-28	96906	47	18
MS35649-284	96906	1	54	MS51957-28	96906	55	58
MS35649-284	96906	21	4	MS51957-28	96906	65	59
MS35649-284	96906	26	7	MS51957-28	96906	67	25
MS35649-284	96906	58	5	MS51957-28	96906	68	25
MS35649-284	96906	58	37	MS51957-28	96906	69	30
MS35649-284	96906	59	17	MS51957-28	96906	70	30
MS35649-284	96906	65	45	MS51957-28	96906	72	15
MS35649-284	96906	93	32	MS51957-28	96906	74	25
MS35649-284	96906	96	11	MS51957-28	96906	75	16
MS35649-42	96906	47	5	MS51957-28	96906	93	3
MS35649-44	96906	58	32	MS51957-28	96906	96	1
MS35649-44	96906	63	4	MS51957-29	96906	52	18
MS35649-44	96906	73	39	MS51957-29	96906	53	5
MS35649-44	96906	93	20	MS51957-29	96906	54	4
MS35649-62	96906	47	14	MS51957-29	96906	75	1
MS35650-104	96906	19	5	MS51957-29	96906	93	12
MS35650-104	96906	29	19	MS51957-30	96906	27	33
MS35650-304	96906	1	60	MS51957-30	96906	30	7
MS35650-304	96906	21	7	MS51957-30	96906	30	142
MS35650-304	96906	23	34	MS51957-30	96906	41	1
MS35650-304	96906	24	26	MS51957-30	96906	46	7
MS35650-304	96906	26	9	MS51957-30	96906	51	8
MS35650-304	96906	64	4	MS51957-30	96906	53	14
MS35690-140	96906	59	20	MS51957-30	96906	58	10
MS35691-2	96906	47	55	MS51957-30	96906	65	22
MS35691-416	96906	73	6	MS51957-30	96906	67	5
MS39078-3	96906	47	69				
MS39087-1	96906	64	10	MS51957-30	96906	96	4
MS39087-3	96906	19	8	MS51957-31	96906	27	38
MS4-140	71785	73	22	MS51957-31	96906	37	5
MS51021-22	96906	30	60	MS51957-31	96906	46	4
MS51957-30	96906	45	1	MS51957-31	96906	47	15
MS51957-19	96906	52	10	MS51957-31	96906	65	17
MS51957-11	96906	34	4	MS51957-31	96906	67	18
MS51957-11	96906	30	137	MS51957-31	96906	68	18
MS51957-11	96906	33	4	MS51957-31	96906	69	23
MS51957-11	96906	35	4	MS51957-31	96906	70	23
MS51957-11	96906	36	4	MS51957-31	96906	73	29
MS51957-12	96906	37	13	MS51957-31	96906	96	22
MS51957-32	96906	27	11				
MS51957-123	96906	30	17	MS51957-32	96906	31	48
MS51957-13	96906	69	4	MS51957-32	96906	66	3

SECTION IV

NATIONAL STOCK NUMBER AND PART NUMBER INDEX

PART NUMBER	FSCM	FIG. NO.	ITEM NO.	PART NUMBER	FSCM	FIG. NO.	ITEM NO.
MS51957-33	96906	21	18	MS51959-32	96906	73	78
MS51957-33	96906	51	4	MS51959-43	96906	65	62
MS 51957-33	96906	59	3	MS51959-45	96906	30	148
MS 51957-4	96906	32	20	MS51959-52	96906	74	96
MS 51957-41	96906	45	37	MS51960-65	96906	64	7
MS 51957-43	96906	27	41	MS51960-65	96906	74	47
MS51957-43	96906	47	72	MS51963-17	96906	73	55
MS51957-43	96906	93	8	MS51963-20	96906	73	77
MS51957-44	96906	1	12	MS51963-20	96906	78	5
MS51957-44	96906	60	2	MS51963-22	96906	73	2
MS 51957-45	96906	1	28	MS51963-22	96906	81	36
MS 51957-45	96906	47	32	MS600-14XXXP1A	75382	27	27
MS51957-46	96906	26	4	MS600-22XXXP40	75382	58	19
MS51957-46	96906	30	81	MS602-4XXXP4A	75382	59	10
MS51957-46	96906	58	6	MS602-7XXXP1A	96906	21	6
MS51957-46	96906	72	12	MS603-3XXXP1A	96906	21	12
MS51957-46	96906	93	15	MS604-2XXXP1C	75382	59	23
MS51957-47	96906	21	1	MS604-8XXXP1C	75382	58	1
MS51957-47	96906	25	5	MS75009-3	96906	65	48
MS51957-47	96906	30	108	MS75009-5	96906	65	47
MS51957-47	96906	58	2	MS77068-2	96906	20	5
MS51957-47	96906	58	40	MS77068-2	96906	65	37
MS51957-48	96906	59	14	MS77068-2	96906	67	22
MS51957-49	96906	76	7	MS 77068-2	96906	68	21
MS51957-5	96906	27	5	MS77068-2	96906	69	27
MS51957-5	96906	37	15	MS77068-2	96906	70	27
MS51957-5	96906	45	14	MS77068-3	96906	65	34
MS51957-7	96906	74	19	MS90311-231	96906	96	15
MS51957-7	96906	74	43	MS90707-4009	96906	32	33
MS51957-7	96906	77	10	MS91528-2K28	96906	22	2
MS51958-11	96906	31	6	MW375-140	08289	53	16
MS51958-11	96906	31	25	MW750-255	08289	56	11
MS51958-11	96906	33	8	M10PLSH19	81312	32	42
MS51958-11	96906	34	8	M10SLRN	81312	37	3
MS51958-11	96906	35	7	M4PLSH9	81312	33	17
MS51958-11	96906	36	7	NMPLSH9	81312	34	17
MS51958-59	96906	26	16	M4SLRN	81312	37	20
MS51958-61	96906	1	31	M5659	74400	96	28
MS51958-61	96906	93	40	M7PLSH9	81312	35	17
MS51958-62	96906	26	12	M7PLSH9	81312	36	17
MS51958-63	96906	1	64	M7SLRN	81312	37	1
MS51958-63	96906	24	22	NAS1397-4	80205	30	105
MS51958-63	96906	64	2	NLW1-12	09023	87	4
MS51958-64	96906	1	22	NLW1-12	09023	89	3
MS51958-64	96906	19	2	NLW 10-12	14655	85	2
MS51958-64	96906	47	74	NLW10-12	14655	87	2
MS51958-64	96906	64	9	NLW10-12	14655	91	1
MS51958-64	96906	71	2	NLW10-12	14655	92	1
MS51958-65	96906	19	9	NLW10-25	14655	90	21
MS51958-69	96906	21	8	NLW10-25	14655	89	1
MS51959-13	96906	33	1	NLW20-12	14655	92	2
MS51959-13	96906	34	1	NPC6	81074	72	14
MS51959-13	96906	35	1	NPC6	81074	93	33
MS51959-13	96906	36	1	NPC7	81074	84	11
MS51959-13	96906	94	8	NPC7	81074	85	21
MS51959-13	96906	95	3	NPC7	81074	86	21
MS51959-14	96906	31	63	NPC7	81074	87	23
MS51959-14	96906	33	19	NPC7	81074	88	27
MS51959-14	96906	73	44	NPC7	81074	89	35
MS51959-14	96906	93	34	NPC7	81074	90	14
MS51959-15	96906	93	42	NPC7	81074	91	26
MS51959-16	96906	23	52	NPC7	81074	92	15
MS 51959-16	96906	58	29	NPC8	81074	93	29
				NPC9	81074	93	13
MS51959-17	96906	1	70	P15D 24VDC	12300	47	33
MS51959-18	96906	65	51	PSUA	76055	30	124
MS51959-18	96906	73	47	P120	02777	46	19
MS51959-2	96906	32	34	P34523JTLHFL	10400	28	3
MS51959-2	96906	72	27	P5500009-09	16512	58	27
MS51959-28	96906	65	38	P5500009-09	16512	23	47
MS51959-28	96906	75	17	QE-17	04222	65	3
MS51959-28	96906	93	41	RB1203	59730	80	3
MS51959-29	96906	65	40	RB1203	59730	94	4
MS51959-30	96906	30	146	RB8863	02032	80	2
				RB863	02032	83	7
MS51959-30	96906	73	50	R8863	02032	94	6
MS51959-30	96906	93	18	R8863	02032	95	7
MS51959-31	96906	72	1				
MS51959-31	96906	73	37	RC07GF101J	81349	97	22
MS51959-32	96906	30	147	RC07GF101K	81349	40	9

SECTION IV

NATIONAL STOCK NUMBER AND PART NUMBER INDEX

PART NUMBER	FSCM	FIG. NO.	ITEM NO.	PART NUMBER	FSCM	FIG. NO.	ITEM NO.
RC07GF102J	81349	8	15	RC20GF101K	81349	62	10
RC07GF102J	81349	8	41	RC20GF101K	81349	68	5
RC07GF102J	81349	17	5	RC20GF102J	81349	48	9
RC07GF102J	81349	29	8	RC20GF102J	81349	49	19
RC07GF102J	81349	97	12	RC20GF102J	81349	55	17
RC07GF103J	81349	8	11	RC20GF102K	81349	40	11
RC07GF103J	81349	29	13	RC20GF102K	81349	62	12
RC07GF103J	81349	97	21	RC20GF102K	81349	67	13
RC07GF103K	81349	40	8	RC20GF102K	81349	68	12
RC07CF122J	81349	17	6	RC20GF102K	81349	69	17
RC07GF123J	81349	97	18	RC20GF103J	81349	50	27
RC07GF133J	81349	4	4	RC20GF103J	81349	55	33
RC07GF152J	81349	9	6	RC20GF103K	81349	70	6
RC07GF152J	81349	17	20	RC20GF104K	81349	62	8
RC07GF152J	81349	29	9	RC20GF121J	81349	17	3
RC07GF183J	81349	8	20	RC20GF121K	81349	67	12
RC07GF183J	81349	97	15	RC20GF121K	81349	70	2
RC07GF183J	81349	97	24	RC20GF124K	81349	62	8
RC07GF202J	81349	97	29	RC20GF150J	81349	55	42
RC07GF203J	81349	40	4	RC20GF150K	81349	70	9
RC07GF203J	81349	97	24	RC20GF151J	81349	55	21
RC07GF221J	81349	97	25	RC20GF151K	81349	67	2
RC07GF222J	81349	5	3	RC20GF151K	81349	68	2
RC07GF222J	81349	9	8	RC20GF151K	81349	69	2
RC07GF222J	81349	14	2	RC20GF152J	81349	48	14
RC07GF222J	81349	15	1	RC20GF152J	81349	49	11
RC07GF222J	81349	16	4	RC20GF152J	81349	50	11
RC07GF222J	81349	17	11	RC20GF152J	81349	55	26
RC07GF222J	81349	97	19	RC20GF153J	81349	50	17
RC07GF223J	81349	14	7	RC20GF153J	81349	55	27
RC07GF223J	81349	97	20	RC20GF154K	81349	62	8
RC07GF223J	81349	97	24	RC20GF181J	81349	69	20
RC07GF243J	81349	97	24	RC20GF182K	81349	67	3
RC07GF272J	81349	8	14	RC20GF182K	81349	68	3
RC07GF272J	81349	97	23	RC20GF182K	81349	69	6
RC07GF273J	81349	97	24	RC20GF182K	81349	70	7
RC07CF274J	81349	17	7	RC20GF184K	81349	62	8
RC07GF302J	81349	8	9	RC20GF202J	81349	48	10
RC07GF331J	81349	8	17	RC20GF202J	81349	49	14
RC07GF331J	81349	97	14	RC20GF202J	81349	50	20
RC07GF332J	81349	8	5	RC20GF203J	81349	29	15
RC07GF362J	81349	29	7	RC20GF221J	81349	55	32
RC07GF391J	81349	8	21	RC20GF221K	81349	70	15
RC07GF391J	81349	97	16	RC20GF222J	81349	55	30
RC07GF392J	81349	15	7	RC20GF223J	81349	55	31
RC07GF392J	81349	17	17	RC20GF223K	81349	62	8
RC07GF392J	81349	97	27	RC20GF224K	81349	62	8
RC07GF472J	81349	8	26	RC20GF271J	81349	49	10
RC07GF472J	81349	8	43	RC20GF271J	81349	56	24
RC07GF472K	81349	40	10	RC20GF271J	81349	70	11
RC07GF473J	81349	8	23	RC20GF273K	81349	62	8
RC07GF473J	81349	97	17	RC20GF3R9J	81349	84	7
RC07GF511J	81349	15	9	RC20GF3R9J	81349	85	9
RC07GF511J	81349	17	19	RC20GF3R9J	81349	86	9
RC07GF511J	81349	97	28	RC20GF300J	81349	56	31
RC07GF561J	81349	8	19	RC20GF331J	81349	55	43
RC07GF562J	81349	8	13	RC20GF331K	81349	40	17
RC07GF562J	81349	97	26	RC20GF331K	81349	67	9
RC07GF563J	81349	8	7	RC20GF331K	81349	68	8
RC07GF621J	81349	8	10	RC20GF332J	81349	48	15
RC07GF681J	81349	8	25	RC20GF332J	81349	55	28
RC07GF682J	81349	8	6	RC20GF332K	81349	62	13
RC07GF682K	81349	40	2	RC20GF332K	81349	69	8
RC07GF751J	81349	8	8	RC20GF333K	81349	62	8
RC07GF752J	81349	8	16	RC20GF361J	81349	49	1T
RC07GF822J	81349	8	24	RC20GF391K	81349	70	17
QC07GF911J	81349	4	11	RC20GF392J	81349	48	18
RC07GF911J	81349	8	18	RC20GF393K	81349	62	8
RC07GF911J	81349	9	7	RC20GF431J	81349	48	8
RC07GF911J	81349	17	21	RC20GF470J	81349	55	23
RC07GF911J	81349	97	13	RC20GF470K	81349	69	7
RC2EB412A31	03522	1	7	RC20GF471J	81349	48	19
RC20GF100J	81349	87	10	RC20GF471J	81349	49	74
RC20GF100J	81349	89	25	RC20GF471J	81349	50	15
RC20GF100J	81349	91	12	RC20GF471J	81349	55	22
RC20GF100J	81349	92	7	RC20GF471K	81349	70	20
RC20GF101J	81349	49	25	RC20GF472J	81349	49	12
RC20GF101J	81349	55	44	RC20GF472J	81349	55	18
RC20GF101J	81349	56	28	RC20GF472K	81349	62	2
RC20GF101K	81349	46	18	RC20GF473K	81349	62	8

SECTION IV

NATIONAL STOCK NUMBER AND PART NUMBER INDEX

PART NUMBER	FSCM	FIG. NO.	ITEM NO.	PART NUMBER	FSCM	FIG. NO.	ITEM NO.
RC20GF510J	81349	48	13	RN60D5111F	81349	50	28
RC20GF510J	81349	49	23	RN60D5620F	81349	50	13
RC20GF563K	81349	62	8	RN60D5621F	81349	49	15
RC20GF680J	81349	8	12	RN60D5621F	81349	55	24
RC20GF680K	81349	66	7	RN60D5621F	81349	88	11
RC20GF681J	81349	50	14	RN60D6810F	81349	48	29
RC20GF681J	81349	55	19	RN60D6811F	81349	88	10
RC20GF681J	81349	56	27	RN60D7321F	81349	8	22
RC20GF681K	81349	62	19	RN60D7500F	81349	49	18
AC20GF681K	81349	67	15	RN60D7501F	81349	49	16
RC20GF681K	81349	68	15	RN60D8250F	81349	48	20
RC20GF681K	81349	69	15	RN60D8250F	81349	88	20
RC20GF683K	81349	62	8	RN60D8251F	81349	88	16
RC20GF751J	81349	48	30	RN60D9531F	81349	50	24
RC20GF752J	81349	49	28	RN65D5620F	81349	88	17
RC20GF752J	81349	50	26	RPB062-059-437	72962	74	70
RC20GF823K	81349	62	8	RPB062-059-437	72962	74	82
RC20GF222G	75042	62	28	RT12C2P502	81349	17	25
RC32GF101K	81349	66	10	RT9343	49956	67	4
RC32GF391J	81349	29	14	RT9343	49956	68	4
RC32GF331K	81349	66	9	RT9343	49956	69	16
RC363	59730	94	2	RT9343	49956	70	8
RC42GF750J	81349	8	27	RW57GR10	81349	56	22
RE65G82RS	81349	27	35	RW57GR20	81349	52	3
RE70G4020	81349	27	36	RW57GR20	81349	53	t
RFV219W2	63743	56	21				
RG20-2000-G	16299	62	9	RW57G510	81349	42	3
RG200-6200-G	16299	62	7	RW57V301	81349	55	41
RG20-910-G	11502	62	26	RW58VR27	81349	53	19
RL20S101G	81349	90	9	RW58VR27	81349	54	1
RL20S102G	81349	90	5	RW59V1R5	81349	56	33
RL20S332G	81349	90	12	RW59V100	81349	53	21
RL205431G	81349	90	18	RWS9V101	81349	56	29
				RW59V102	81349	49	26
RL20S472G	81349	90	3	RW59V151	81349	52	15
RL20S561G	81349	89	28	RW59V151	81349	55	38
RL32S102G	81349	88	18	RW59V182	81349	50	10
RL32S560G	81349	88	14	RW59V2R2	81349	55	45
RL42S101G	81349	89	20	RW59V202	81349	50	16
RN60C1781F	81349	55	25	RW59V202	81349	56	32
RN60C1782F	81349	55	40				
RN60C1871F	81349	49	21	RW59V601	81349	53	2
RN60C2871F	81349	50	22	RW59V601	81349	54	14
RN60D1001F	81349	48	26	RW59V601	81349	56	34
RN60D1002F	81349	55	34	RW67V270	81349	98	17
RN60D1002F	81349	88	12	RW68V750	81349	88	9
RN60D1152F	81349	48	17	RW69V1R0	81349	62	21
RN60D1152F	81349	55	39	RW69V151	81349	89	27
RN60D121F	81349	55	36	RW69V471	81349	50	19
RN60D121F	81349	88	15	RW69V680	81349	29	16
RN60D1210F	81349	17	22	RW79V5621F	81349	55	52
RN60D1211F	81349	48	23				
RN60D1211F	81349	55	49	R1980N	02032	76	4
RN60D1401F	81349	48	24	R8	92830	74	27
RN60D1402F	81349	55	50	S-1006-5	03522	60	5
RN60D1582F	81349	55	48	S-1309	03522	60	6
				S-1364	03522	60	7
RN60D1621F	81349	48	27	S-1365	03522	60	8
RN60D1621F	81349	49	20	S-1783	03522	60	1
RN60D1621F	81349	55	29	SC408	09214	46	20
RN60D1821F	81349	55	35	SDT1055	13327	63	10
RN60D1960F	81349	48	11	SKT5BCBLK	98291	57	9
RN60D1961F	81349	48	16	SKTBCGRN	98291	57	3
RN60D1961F	81349	49	29	SMB546131	80063	23	42
RN60D2151F	81349	48	28	SMB546131	80063	58	22
RN60D2151F	81349	55	46	SMB546132	80063	20	1
RN60D2211F	81349	55	37	SMB546216	80063	23	45
RN60D2213F	81349	88	19	SMB546216	80063	58	25
RN60D2610F	81349	48	21	SMB546299	80063	20	15
RN60D2741F	81349	17	24	SMB546534	80063	98	14
RN60D3011F	81349	50	12	SMB634754	80063	1	16
RN60D3162F	81349	50	25	SMB634803	80063	1	32
RN60D3480F	81349	48	12	SMB634809	80063	23	41
RN60D3480F	81349	49	13	SMC546211-3	80063	65	8
RN60D3481F	81349	55	20	SMC546211-4	80063	65	13
RN60D3482F	81349	55	51	SMC546211-7	80063	65	54
RN60D3831F	81349	50	21	SMC634786	80063	18	2
RN60D4640F	81349	48	25	SMC634816	80063	1	61
RN60D4640F	81349	49	9	SMC634831-3	80063	1	55
RN60D4641F	81349	88	13	SMD546276-1	80063	1	17

SECTION IV

NATIONAL STOCK NUMBER AND PART NUMBER INDEX

PART NUMBER	FSCM	FIG. NO.	ITEM NO.	PART NUMBER	FSCM	FIG. NO.	ITEM NO.
SMD634807-2	80063	20	13	00-001585-2	06809	96	18
SME546656	80063	2	18	00-001592-1	12436	75	12
SME1546657	80063	18	1	00-001592-1	12436	76	17
00-001659-001	06809	65	20				
SN7400J	01295	97	33	00-001660-002	12436	65	55
SN7402J	01295	97	31	00-6022-022-940-002	91662	47	43
SN7401J	01295	97	32	01-002882-2	06809	96	23
SN7474J	01295	97	34	01-002883-2	06809	96	29
SS0762	03508	84	6	01-002884-1	06809	1	71
SS0762	03508	85	5	01-002906-1	06809	1	75
SSD762	03508	86	5	01-002980-1	06809	1	74
SS0762	03508	87	6	01-003078-001	06809	65	64
SS0762	03508	88	4	01-003080-001	06809	65	60
SS0762	03508	89	7	01-003081-003	06809	66	5
SS032-2	46384	47	63	01-003082-001	06809	65	21
SS632TCHHMPB	40920	31	64	01-003084-001	06809	65	44
S632-2	46384	47	28	01-003085-002	06809	65	39
S632-2	46384	56	6	01-003086-001	06809	67	23
S663-2FCHHMPB	40920	31	61	01-003086-001	06809	68	22
S832-2	46384	47	73	01-003086-001	06809	69	28
TC125	59730	23	54	01-003086-001	06809	70	28
TC125	59730	28	4	01-003087-002	06809	69	21
TC125	59730	58	34	01-003087-004	06809	68	16
TC125	59730	98	6	01-003087-005	06809	70	21
TE1204	56289	85	1	01-003087-011	06809	67	16
TE1204	56289	87	1	01-003241-001	06809	72	25
TE1204	56289	91	2	01-003336-001	06809	32	35
TP501	08289	84	9	01-003337-001	06809	32	29
TP501	08289	85	19	01-00389-001	06809	65	63
TP501	08289	87	21	03-001477-001	06809	65	53
TP501	08289	88	23	04-001393	12436	96	19
TP501	08289	89	34				
TP501	08289	90	19	1-5R75	13327	62	72
TP501	08289	91	25	1-480275-2	00779	56	3
TP501	08289	92	14	1-480275-3	00719	56	4
TRU516-25	08289	56	12	1-480275-5	00779	56	8
TW-20	13327	62	24	1-480275-6	00779	56	2
TYPED1-8X3-4	83584	79	4	1-480275-9	00779	56	5
TYPED1-8X3-8SS	83584	74	90	1-480278-2	00779	53	8
TYPED1-8X3-4SS	83584	75	6	1-480278-3	00779	53	10
TYPED1-8X3-8SS	83584	74	12	1-480278-5	00779	52	6
TYPED1-8X3-8SS	83584	75	8	1-480278-6	00779	52	8
TYPEU2X1-8	70318	79	2	1-480278-9	00779	54	6
T00023-001	12436	8	45	1-480416-0	00779	98	2
T00023-002	12436	8	35	1DP2-473	72136	91	4
T00024-001	12436	8	38	1N1184	81349	52	14
T00024-002	12436	8	36	1N1200	81349	53	13
T00121-004	12436	8	44	1N1202	81349	52	4
T00122-002	12436	8	37	1N276	81349	85	4
T163-2C24VDC	02288	65	26	1N276	81349	86	4
T163-4C12VDC	02288	65	24	1N276	81349	87	5
VR56A	51589	89	8	1N276	81349	88	2
V146XR001200V	50930	69	18	1N276	81349	89	5
V146XR0047200V	04222	67	14	1N276	81349	91	6
V146XR0068200V	04222	70	18	1N276	81349	92	4
V146XR047200V	04222	68	14	1N3022A	81349	50	5
W-7712-C1-A	08715	61	12	1N404	81349	92	5
W-7712-C1-B	08715	61	12	1N4148	81349	55	8
W-7712-C1-C	08715	61	12				
W-7712-C2-A	08715	61	13	1N4997	04713	66	1
W-7712-C2-B	08715	61	13	1N4997	04713	67	6
W-7712-C2-C	08715	61	13	1N4997	04713	68	6
W-7712-10	08715	61	11	1N4997	04713	69	9
W-7712-13	08715	62	1	1N4997	04713	70	10
W-7712-15	08715	63	12	1N5059	80131	49	6
W-7712-16	08715	61	16	1N5059	80131	55	7
W-7712-24	08715	61	10	1N5059	80131	56	26
W-7712-26	08715	61	1	1N5059	80131	97	8
W-7712-27	08715	61	3	1N5059	80131	98	16
W-7712-28	08715	61	17	1N536	96214	66	8
W-7712-3-5A	08715	1	6	1N537	81349	88	5
W-7712-30	08715	61	15	1N537	81349	89	10
W-7712-7	08715	63	1				
W-7712-9	08715	61	7				
WG-0201	95987	96	3	1N750A	80131	40	1
W88CPX5	94696	65	31	1N751	81349	66	6
XL5223A1SC	09454	17	23	1N751	81349	67	10
Z97RBXR1CJ	43334	74	28	1N751	81349	68	10
Z97R6XR1CJ	43334	74	75	1N751	81349	69	13
00-001563-5	06809	1	5	1N751	81349	70	14

SECTION IV

NATIONAL STOCK NUMBER AND PART NUMBER INDEX

PART NUMBER	FSCM	FIG. NO.	ITEM NO.	PART NUMBER	FSCM	FIG. NO.	ITEM NO.
1N752A	81349	62	18	12-870140-003	06809	60	23
1N754A	81349	55	10	12-870140-004	06809	10	29
1N754A	81349	62	4	12-890096-2	12436	96	25
12-890129-1	12436	96	7				
1N823	81349	48	5	12-089040-002	12436	65	33
1N823	81349	49	4	12-890141-002	12436	65	14
1N942	81349	50	4	17-890142-002	12436	65	9
1N9638	81349	48	3	12-890143-001	124'6		2
10	02751	73	15	1204-03	78189	74	52
10-5290701	12436	73	63	1204-03	78189	75	14
10EALC1	96182	23	23	1264-1	71279	73	23
10EA1T5V13FEEDOUT	96182	23	27	1300-9	71279	88	26
10EFI	96182	23	24	1300-9	71279	89	33
10EF3	96182	23	24	135511	12344	31	69
10ELAOOA	96182	23	25	135540	12344	82	15
10ELAOOA	96182	23	25	135550	12344	82	8
10ELROOI	96182	23	25	135560	12344	82	10
10ELWGGW	96182	23	25	138240	12344	82	16
10ELWVWWW	96182	23	25	141J	71785	46	5
10ELWOOW	96182	23	25	145020	12344	30	46
10ENI	96182	23	26				
10EN2	96182	23	26	146043	12344	37	4
10ER1TSV13LOCALTEST	96182	23	27	146043	12344	45	39
10ERLTSV12START	96182	23	27	146701	12344	44	13
10ER1TSV12STOP	96182	23	27	1500226X1001582	56289	62	6
10ER1TSV13ACPOWER	96182	23	27	150D274X9035A2	56289	89	4
10ER1TSV13AUOIBLERESET	96182	23	27	150D475X003582	56289	62	11
10ER1TSV13LAMPTEST	96182	23	27				
10ER1TSV13PRINTINDEPENDENT	96182	23	27	1500824X9035A2	56289	90	10
10ER1TSV6WIDE/NARROW	96182	23	27	1552101	12436	1	10
10JX63	56289	59	13	1606-00	78189	72	6
100-1K	75012	91	17	164-10	05277	54	12
100-5K	75042	89	18	165800	12344	45	24
100-50K	75042	90	11	17-31	81349	63	8
10079	07047	8	33	1704-00	78189	88	25
10079	07047	17	28	1704-00	78189	89	32
10079	07047	29	18	18808	71041	31	71
10079	07047	68	13	18808	71041	33	23
10079	07047	69	19	18808	71041	35	23
10079	07047	97	36	18808	71041	45	42
101620AP	07047	86	19	1988-2	71279	73	24
10231-1	34631	73	1	2-0-220	94222	27	15
105-751-10	74970	29	3	2-323930-2	00779	58	28
105-752-10	74970	29	6	2-323934-2	00779	1	50
105-753-10	74970	29	4	2-323934-2	00779	28	2
105-754-10	74970	29	25	2A200	13327	62	23
105-756-10	74970	29	23	2D0H60L471K	71590	40	7
105-757-10	74970	29	24	206-29F	86577	52	2
105-758-10	74970	29	5	Z06-29F	86577	53	4
105-760-10	74970	29	26	206-29F	86577	54	8
105-762-10	74970	29	1	2N1605	80131	91	9
105-763-10	74970	29	2	2N1605	80131	89	13
11SM1T	91929	46	14	2N1711	81349	48	6
11SM1T	91929	74	21	2N1711	81349	49	7
11SM1T	91929	74	42	2N1711	81349	50	7
11SM1T	91929	77	9	2N1711	81349	55	14
11SM237	91929	30	65	2N2243A	80131	50	9
11SM23T	91929	37	18	2N2243N	81349	55	13
1100107X005010	56289	62	20	2N2323	81349	55	9
11265	06809	74	37	2N2612	80131	88	7
1139	70485	47	34	2N2612	80131	89	14
1178-2	70485	24	5	2N2905	81349	48	7
1185-06CNX207	01556	73	62	2N2905	81349	49	8
1185-2CNX164	01556	73	61	2N2905	81349	50	6
1185-2CNX246	01556	74	11	2N2905A	81349	50	8
1185-2CNX246	01556	74	56	2N2905A	81349	55	15
1185-3CNX190	01556	76	13	2N3012	80131	85	8
1197-30	96182	23	17	2N3012	80131	86	8
1197-31	96182	23	15	2N3012	80131	87	9
1197-32	96182	23	10	2N3055	81349	52	5
1197-33	96182	23	11	2N3055	81349	53	3
1197-34	96182	23	8	2N3055	81349	55	16
1197-37	96182	23	16				
1197-39	96182	23	12	2N3565	80131	40	6
1197-40	96182	23	14	2N3638	34148	85	6
1197-41	96182	23	13	2N3638	34148	86	6
12-870096-2	06809	97	35	2N3638	34148	87	7
12-870129	06809	98	18	2N3638	34148	91	8
12-870140-001	06809	69	29	2N3638	34148	84	1
12-870140-002	06809	67	24	2N3642	80131	90	2

SECTION IV

NATIONAL STOCK NUMBER AND PART NUMBER INDEX

PART NUMBER	FSCM	FIG. NO.	ITEM NO.	PART NUMBER	FSCM	FIG. NO.	ITEM NO.
2N3644	80131	90	4	3X.68	63743	67	1
2N3738	81349	62	17	3X1	63743	69	1
2N3906	80131	62	5	3X1	63743	69	1
2N404	81349	85	7	3X1300	63743	69	11
2N404	81349	86	7	3X3000	63743	50	18
2N404	81349	87	8	3X470	63743	67	11
2N404	81349	88	6	3X470	63743	64	11
2N404	81349	89	15	3X1470	63743	69	14
2N404	81349	91	10	3X470	63743	70	16
2N491	81349	88	8	3X6000	63743	52	20
2N4986	80131	55	11	300030	12344	30	114
2N657	981349	62	25	300070	12344	31	20
2N682	81349	56	10	300081	12344	31	21
				300172	12344	31	23
2N697	80131	40	12	300260	12344	31	46
2N797	80131	84	2	300280	12344	31	22
20JX35	56289	59	18	300300	12344	81	25
200150-001	16512	20	6	300362	12344	32	62
200150-02	16512	27	13	300371	12344	31	10
200150-02	16512	96	24	300371	12344	31	35
203413-0	82654	21	14	300371	12344	33	11
215842	12344	82	6	300371	12344	34	11
216830	12344	81	21	300371	12344	35	10
2185	83330	45	5	300390	12344	38	5
2186-2	71279	40	5	300400	12344	3	30
2186-2	71279	42	2	300400	12344	35	30
2186-2	71279	46	22	300410	12344	32	49
220445	12344	30	99	300430	12344	33	28
220534	12344	31	24	300430	12344	35	28
220535	12344	82	18	300480	12344	33	10
223760	12344	31	28	300480	12344	34	10
223760	12344	82	25	300480	12344	35	9
223770	12344	31	7	300480	12344	36	9
223770	12344	31	27	300500	12344	31	75
225371	12344	31	78	300511	12344	31	62
225371	12344	81	30	30052	12344	38	10
225372	12344	31	79	300522	12344	38	9
225372	12344	81	29	30055-1	02288	65	25
225373	12344	31	65	30055-	02288	65	23
225373	12344	44	7	300580	12344	32	54
225373	12344	81	31	300600	12344	30	45
225374	12344	31	42	300630	12344	31	73
225374	12344	33	25	300640	12344	31	67
2253714	12344	35	25	300640	12344	81	27
225374	12344	45	29	300650	12344	35	12
225374	12344	82	1	300661	12344	33	6
225375	12344	30	28	300662	12344	34	6
225375	12344	31	43	300711	12344	35	2
225375	12344	33	26	300712	12344	33	2
225375	12344	35	26	300713	12344	34	2
225375	12344	45	18	300721	12344	35	3
225375	12344	82	2	300721	12344	36	3
225376	12344	31	44	300722	12344	33	3
225376	12344	33	27	300722	12344	34	3
225376	12344	35	27	300730	12344	33	21
				300730	12 344	35	21
225376	12344	45	19	300760	12344	32	50
225376	12344	82	3	300780	12344	31	59
225377	12344	82	13	300860	12344	37	19
226374	12344	31	8	300890	12344	31	72
226374	12344	31	38	300940	12344	33	12
226374	12344	82	28	300940	12344	34	12
228763	12344	45	48	300940	12344	35	1
228761	12344	45	49	300940	12344	36	11
229030	12344	81	18	301040	12344	32	55
2490	80201	30	20	301050	12344	31	60
25F10	63743	65	49	301100	12344	30	44
25F200	63743	65	50	301160	12344	31	76
250-1-30-220	71785	65	12	301201	12344	31	18
250-25-36-170	71785	47	3	301810	12344	31	39
250-26-16PGDSP	95238	30	64	304182	12344	81	6
25026-165G05	95238	1	39	304211	12344	81	24
29-479	12697	67	8	304213	12344	30	96
29-479	12697	68	9	304213	12344	45	31
29-479	12697	69	12	304216	12344	44	1
29-479	12697	70	12	304216	12344	81	22
29A	79963	56	13	304260	12344	32	7
290050-01	16512	27	18	304282	12344	81	19
290050-1	16512	96	26	304282	12344	82	11
3SX1T	91929	32	18	30430	12344	44	9

SECTION IV

NATIONAL STOCK NUMBER AND PART NUMBER INDEX

PART NUMBER	FSCM	FIG. NO.	ITEM NO.	PART NUMBER	FSCM	FIG. NO.	ITEM NO.
304370	12344	31	13	323230	12344	30	36
304370	12344	31	32	323241	12344	30	39
304370	12344	33	9				
304370	12344	34	9				
304370	12344	35	8	324680	12344	30	21
304370	12344	36	8	324741	12344	30	102
304370	12344	82	22	324960	12344	32	26
30441	34631	71	7	324980	12344	30	19
30442	34631	71	6	325110	12344	39	8
304670	12344	30	2	325171	12344	39	14
304670	12344	30	57	325330	12344	32	56
				325340	12344	32	57
304680	12344	30	59	325350	12344	36	2
304702	12344	30	56	325370	12344	36	12
304920	12344	32	61	325450	12344	38	8
304993	12344	30	38	32S460	12344	38	6
305081	12344	30	100	325470	12344	38	3
305110	12344	30	133	325480	12344	32	58
305300	12344	33	14	325611	12344	32	43
305300	12344	34	14	326231	12344	30	50
305300	12344	35	14	327220	12344	34	15
305300	12344	36	14	327121	12344	33	15
305651	12344	31	17	327300	12344	37	8
305651	12344	31	29	328990	12344	30	51
305652	12344	31	16	329000	12344	39	7
305652	12344	31	31	329080	12344	39	13
305653	12344	31	15	329090	12344	39	5
305653	12344	31	30	329100	12344	39	2
305653	12344	45	72	329260	12344	39	11
306150	12344	33	18	3293-3-16	61007	90	15
306150	12344	34	18	329361	12344	30	54
306150	12344	35	18	329790	12344	32	41
306150	12344	36	18	329870	12344	36	16
307460	12344	32	63	329871	12344	35	16
308950	12344	33	22	329880	12344	32	39
308950	12344	35	22	329881	12344	32	47
309790	12344	32	46	329890	12344	32	53
309791	12344	32	45	329891	12344	32	52
309792	12344	32	44	329900	12344	81	26
309793	12344	39	4	329930	12344	32	23
31E2	83186	76	32	329980	12344	32	6
310640	12344	31	68	329990	12344	32	5
310640	12344	8	28	330	08806	23	28
312040	12344	44	11	330000	12344	32	13
313740	12344	31	12	330010	12344	32	21
313740	12344	31	34				
313740	12344	82	20				
314370	12344	81	2				
316500	12344	30	30	330160	12344	32	24
317430	12344	38	7	330190	12344	32	25
318460	12344	31	9	330230	12344	32	14
318460	12344	31	37	330230	12344	45	67
318460	12344	82	19	330420	12344	30	43
319760	12344	30	95				
318770	12344	30	93	330620	12344	30	118
318790	12344	30	18	330621	12344	30	63
318640	12344	30	26	331500	12344	30	73
318841	12344	30	24	331840	12344	32	27
318850	12344	30	27	331850	12344	32	22
318870	12344	30	4	331860	12344	32	1
318870	12344	30	58	331940	12344	25	1
				332010	12344	32	28
319890	12344	32	60	332190	12344	30	122
319940	12344	31	3	332311	12344	30	116
319950	12344	31	4	332320	12344	30	61
3201430015AF6C	56289	65	4	332833	12344	33	16
320322G015AA6C	56289	65	56	332833	12344	34	16
320222	12344	30	23	332843	12344	35	15
320880	12344	30	104	332843	12344	36	15
320890	12344	30	101	333050	12344	73	58
320900	12344	30	103	333052	12344	30	1
320950	12344	30	22				
321010	12344	41	3	333052	12344	45	33
321011	12344	+0	16				
32115-1	14655	65	6	333550	12344	32	30
321370	12344	30	94	333610	12344	32	17
321440	12344	30	131				
322700	12344	35	31				
322701	12344	33	31				
323221	12344	30	14				

SECTION IV

NATIONAL STOCK NUMBER AND PART NUMBER INDEX

PART NUMBER	FSCM	FIG. NO.	ITEM NO.	PART NUMBER	FSCM	FIG. NO.	ITEM NO.
333810	12344	44	6	376670	12344	41	7
333900	12344	82	5	376700	12344	30	12
333900	12344	82	4	376710	12344	44	10
333920	12344	82	14	376720	12344	30	123
333930	12344	81	23	376940	12344	30	85
333940	12344	81	33	376970	12344	46	8
333950	12344	81	20	377030	12344	30	75
333960	12344	81	3	377220	12344	30	67
				377230	12344	30	66
335571	12344	30	31	377270	12344	30	74
338920	12344	30	129	378510	12344	82	26
				378600	12344	30	11
34D258G015HP4	56289	66	2	38-100137-002	88422	31	2
34D507G025FP4	56289	69	10	S80010	12344	45	77
34D507001025P4	6289	67	7	381160	12344	30	88
34D907G10FL4	56289	68	7	156	15306	61	2
34D9700G10FL4	S6289	70	13	386	75306	63	9
34D023010L	12344	30	84	38939	98675	54	11
340631	12344	31	45	389620	12344	45	5
340631	00779	52	22	389700	12344	5	45
34113	00179	52	13	389992	12344	82	9
34113	00179	56	9	39359	12344	47	57
341820	12344	30	138	393910	12344	37	9
341521	12344	30	3	343940	12344	30	115
				393950	12344	30	113
3473502	34631	72	23	394040	12344	37	12
347760	12344	39	10	394220	12344	39	6
34835	06809	38	22	396130	12344	39	15
349840	12344	31	56	396140	12344	31	55
349841	12344	31	58	396430	12344	45	9
35-H-11P1-200P112	56289	65	7	396620	12344	45	16
35F4898A	01002	30	126	396820	12344	1	16
351800	12344	31	40	397960	12344	45	20
352370	12344	30	130				
353550	12344	45	70	4M104	96733	17	12
355622	12344	31	57	40-000004-	06809	52	23
35622	12344	81	1	40-000004-1	06809	53	25
356280	12344	82	24	40-000004-1	06809	54	16
356280	12344	45	56	40-000006-1	06809	48	31
356550	12344	45	73	40-000009-1	06809	49	30
356561	12344	45	16	40-000011-1	12436	47	44
356571	12344	45	57	40-000012-1	06809	50	29
356571	12344	45	71	40-000014-1	12436	47	41
358950	12344	33	29	40-000015-1	06809	51	7
358950	12344	35	29	40-000017-1	06809	51	9
358950	12344	45	61	40-000030-100	06809	53	2
359340	12344	45	62	40-000039-1	06809	51	3
359370	12344	45	69	40-000042-1	06809	41	2
359410	12344	45	53	40-000045-1	06809	51	1
359531	12344	45	60	40-00005-1	0609	55	54
35541	12344	45	55	40-000S2-1	12436	41	20
359590	12344	43	25	40-000062-1	06809	47	12
359900	12344	45	59	40-000064-1	061809	57	1
360223P015068	56289	26	14	40-000065-1	06809	47	62
36D223P07068	56289	27	3	40-000066-01	06809	47	6
360708	12344	45	34	40-000066-2	06809	47	1
3645	80201	31	1	40-000067-1	06809	47	26
365600	12344	32	4 8	40-000067-2	06809	47	6
365630	12344	31	66	40-000016-1	06809	47	68
370580	12344	45	27	40-000018-1	06809	47	42
373590	12364	46	17	40-00008-1	06809	47	42
373600	12344	45	35	40-000081-1	06809	47	2
373610	12344	45	38	40-000083-1	06809	1	4
373620	12344	1	9	40-000093-1	06809	1	4
313990	12344	45	36	40-000095-1	06809	47	2
374000	1234	45	43	40-000097-1	06809	5	1
374010	12344	45	41	40-000109-1	06809	56	1
374020	12344	45	40	40-000110-105	06809	47	66
374030	12344	45	23	40-00011-1	12436	53	17
314040	12344	45	32	40-000113-1	12439	56	23
374050	12344	45	64	40-00014-1	06809	47	2
317460	12344	45	30	40-000116-1	06809	47	61
3174070	12344	45	2	40-000120-1	06809	47	23
374450	012344	45	10	40-000124-1	06809	36	48
371950	12344	39	12	40-000126-1	12436	50	2
374970	12344	44	3	40-000133-1	12436	55	53
314990	92830	74	7	40-0001067-1	06804	5	5
3715-1	92830	79	9	40-000182-1	06809	55	11
371530	12344	30	71	40-0001199-11	06809	56	20
37331	12344	30	92	40-01060012BB0	56289	86	2

SECTION IV

NATIONAL STOCK NUMBER AND PART NUMBER INDEX

PART NUMBER	FSCM	FIG. NO.	ITEM NO.	PART NUMBER	FSCM	FIG. NO.	ITEM NO.
40D106G025BB0	56289	86	1	4176150	12344	82	27
40D106G02BB0	56289	84	13	4177150	12344	30	37
400009-05	12344	81	17	4178700	12344	38	12
400216-09	12344	81	5	4178820	12344	30	33
400498-11	12344	81	12	4179100	12344	30	78
400595-01	12344	81	15	4179210	12344	32	15
400617-27	12344	38	1	4179500	12344	30	69
4018300	12344	30	89	43-13-1-23	94222	27	17
40250	02735	67	21	44193G2	12436	72	16
40250	02735	68	17	44194G2	12436	72	18
40250	02735	69	3	4419502	12436	72	19
40250	02735	70	3	44196G2	12436	72	20
40638G1	06809	93	23	44197G2	12436	72	22
40639G1	06809	73	42	44293G1	06809	85	18
40640G1	06809	93	9	44294	06809	87	20
40809	98675	49	5	44295	06809	92	13
4083300	12344	45	75	44296	06809	91	24
4094415	12344	32	32	44297	06809	89	30
4097900	12344	30	135	44303G2	12436	72	24
4097905	12344	41	6	44306G2	12436	72	17
4099080	12344	30	115	44403G1	06809	84	14
4106350	12344	45	54	44406	06809	86	15
4106375	12344	45	26	44452G2	12436	72	21
4107200	12344	45	47	44552	06809	90	1
4107310	12344	45	44	4535-100-18	96182	22	8
4108400	12344	46	10	456-99-99-193	71785	47	7
4110300	12344	37	2	4586-2A	56299	26	15
4110600	12344	30	145	4586-97A	56289	27	28
480065-3	02660	30	86				
49-1-1-0	94222	57	7				
4116155	12344	46	13	49-1-1-0	94222	1	24
414570	12344	30	48	49-1-1-0	94222	22	3
4153010	12344	30	79	49-1-1-0	94222	64	11
4153750	12344	31	11	5-140	71785	46	1
4153800	12344	32	16	5KC19SG34	03494	30	112
4153900	12344	30	98	5KH4FG1106T	03510	80	1
4153900	12344	45	63	505	79963	53	22
4153910	12344	44	5				
4154225	12344	32	64	5100-31	79136	74	65
415440	12344	82	17	5103-1BMO	79136	44	2
4154900	12344	45	66	5103-1BMO	79136	82	12
4155050	12344	51	34	5103-25MO	79136	30	13
4155300	12344	38	11	5103-31MO	79136	30	25
4155600	12344	38	4	511-041800-00	78189	32	38
4155900	12344	81	32	5133-12	79136	77	2
4156400	12344	31	36	5133-18	79136	73	17
4156700	12344	30	42	5133-18	79136	73	57
4156775	12344	32	65	5133-25MO	79136	31	77
4157500	12344	82	21	5133-25MO	79136	33	24
4158110	12344	44	4	5133-25MO	79136	35	24
4158520	12344	44	8	519951	12344	45	51
4159000	12344	45	46	519953	12344	45	50
				52-012-062-0312	72962	74	60
4160100	12344	30	29	52517-1	34631	74	63
4160300	12344	31	47	52519-1	06809	74	4
4160500	12344	30	80	52549-1	34631	74	64
4161100	12344	30	34	52563-1	06809	74	71
4163500	12344	44	12	52571-1	12436	74	83
41639500	12344	45	17	52575-1	34631	74	81
4164150	12344	30	70	52576G1	06809	174	0
4164800	12344	30	72	52605G1	06809	74	20
4165375	12344	30	107	52605-1	06809	74	41
4165500	12344	30	150	52610-1	06809	74	32
4165560	12344	30	91	52612-1	06809	74	95
41663	00779	30	62	52620-1	06809	74	22
41663	00779	37	14	52620-1	06809	14	40
41663	00779	46	9	52620-1	06509	77	8
4166850	12344	45	4	52629-1	06809	74	23
4169200	12344	30	40	52629-1	06809	74	39
4169600	12344	30	35	52639-1	06809	74	87
4171900	12344	30	134	52640-1	06809	74	91
4171900	12344	31	53	5264001	06809	74	89
4171900	12344	81	7	52641-1	06809	74	16
4172900	12344	30	83	52641-1	06809	74	15
4172900	12344	41	8	52642-1	06809	74	30
4173250	12344	30	82	52646-1	34631	74	76
4173600	12344	45	12	52647-1	34631	74	69
4175050	12344	30	17	52654-2	06809	74	47
4175300	12344	30	32	52658-1	06809	74	29
4175400	12344	30	68	52661-1	12436	74	31

SECTION IV

NATIONAL STOCK NUMBER AND PART NUMBER INDEX

PART NUMBER	FSCM	FIG. NO.	ITEM NO.	PART NUMBER	FSCM	FIG. NO.	ITEM NO.
52665-1	06809	74	55	56369-1	06809	73	60
52665-1	06809	74	54	56370-1	34631	73	73
52666-1	06809	74	10	56372-1	06809	73	66
52666-1	06809	74	48	56373-1	06809	73	61
52670-1	06809	72	2	56375-1	06809	73	56
52679-2	06809	74	77	56377-1	06809	73	56
52681-1	06809	74	59	56380-1	06809	76	27
52682-1	06809	75	1	56380-1	06809	76	8
52682-1	06809	75	5	56386-2	06809	73	59
52782-1	34631	71	1	56407-1	06809	5	3
52790-1	06809	14	38	56497-1	06809	75	11
52791-1	06809	74	18	56510-1	06809	76	29
52795-1	06809	93	27	56511-1	06809	76	20
52796-1	06809	78	2	56511-1	06809	76	19
52797-1	06809	77	6	56514-1	06809	73	30
52798-1	06809	77	14	56515-1	06809	76	30
52799-1	06809	78	1	56517-1	06809	73	51
52800-1	34631	78	4	56518-1	34631	75	9
52802-1	12436	77	1	56519-2	12436	76	26
52804-2	06809	77	12	56553-1	06809	73	48
52805-1	06809	93	7	56554-1	06809	73	49
52806-1	06809	77	7	56555-1	06809	73	31
52810-1	06809	77	5	56566-2	06809	93	35
52163-1	06809	73	72	56566-1	06809	93	38
52865-1	06809	74	67	56626-1	06809	76	21
52861-1	06809	74	6	56626-12	06809	94	9
52870-1	06809	73	14	56626-14	06809	95	1
52872-1	06809	73	4	56626-3	06809	83	6
52873-1	12436	73	16	56626-6	06809	95	6
52876-1	06809	74	5	56626-1	06809	83	1
52877-1	06809	74	4	56626-9	06809	94	5
52887-1	06809	74	44	56645-1	06809	16	25
52888-1	06809	74	66	56646-1	34631	74	62
52889-1	06809	74	14	56648-2	12436	76	24
52899-1	06809	72	7				
52906-1	06809	73	81	56671-1	06809	74	94
52912-1	06809	72	29	56675-1	06809	76	1
52920-1	06809	73	43	56679-1	06809	74	85
52924-1	34631	74	57	56680-2	06809	75	18
52940-1	06809	74	99	56681-1	06809	73	64
52945-1	06809	13	10	56979-1	06809	73	79
52948-1	06809	74	78	58-30-40	07556	41	25
52962-1	06809	16	28	58877-1	06809	74	13
52964-1	06809	74	93	59335-1	34631	16	23
52977-61	06809	77	4	6-140	71785	30	143
52978-1	06809	76	2	6-170	71785	65	52
52981-1	06809	73	27	60-6002-31-24	91662	47	36
52991-1	06809	74	49	600C-14UH	75382	27	47
52996-1	06809	74	46	600C-22UH	75382	58	14
540027-006	12436	96	6	600RJS2	75387	27	26
540111-04	16512	20	12	600RJS4	75382	27	24
540123-03	16512	20	11	600RJS6	753B2	27	25
540362-06	16512	23	46	600SP	75382	73	20
540362-06	16512	58	26	600002-2	05439	24	6
540362-06	16512	98	11	600002-3	05439	24	8
540911-13	58189	96	27	600002-5	05439	24	17
550056-01	16521	20	10	600027-01	12344	30	87
5555-12190	19136	30	137				
5555-12MD	79136	45	58	600027-02	12344	30	106
5555-12MD	79136	45	74	600100-1	05439	24	29
5555-25MD	79136	45	28	600102-1	05439	24	25
5555G9M0	79136	32	9	600103-1	05439	24	28
5555G9MO	79136	39	3	600105-4	05439	24	7
559998	12436	1	43	600108-1	05439	24	21
56010-1	34631	79	3	600109-1	05439	24	31
56044-1	06809	73	3	600109-2	05439	24	33
56056-G1	06809	64	1	600110-1	05439	24	3
5600-1	06809	73	74	600111-1	05439	24	9
56074-1	06809	73	68	600111-1	05439	24	19
56092-1	34631	73	75	600111-2	05439	24	12
56115-1	06809	78	3	600111-2	05439	24	16
56116-1	34631	76	14	600111-3	05439	24	11
56219-1	06809	72	11	600111-3	05439	24	15
56223-1	06809	73	7	600112-1	05439	24	10
56254-1	06809	93	31	600112-1	05439	24	14
56255-1	06809	79	1	600501-1	05439	1	11
56313-1	06809	93	1	600502	05439	24	1
56359-1	06809	74	84	600503-1	05439	24	16
56365G1	06809	79	5	600503-3	05439	24	20
56368G6	06809	73	71	600503-5	05439	24	13

SECTION IV

NATIONAL STOCK NUMBER AND PART NUMBER INDEX

PART NUMBER	FSCM	FIG. NO.	ITEM NO.	PART NUMBER	FSCM	FIG. NO.	ITEM NO.
600504	05439	24	4	80EA1F1RL2N13PUNCHERROR	96182	23	5
601468-1	12344	30	41	80EA1F1RL2N13PUNCHFUSE	96102	23	7
602C-3145T7UH	75382	21	5	80EA1F1RLZN13TAPEOUT	96182	23	3
602CY151	75382	47	27	80EA1F1RL2N13TIGHTTAPE	96182	23	21
602C4UH	75382	59	1	80EA1F1WL2N13DCPOWER	96182	23	9
602040-1	12344	73	34	80EF1A	96182	23	30
602071-1	12344	81	35	80EF1R	96182	23	30
602072-1	12344	81	13	80EF1W	96182	23	30
602092-1	12344	81	14	80EL2N13DCPOWER	96182	23	31
602093-1	12344	81	4	80EL2N13LOWTAPE	96182	23	31
603-C-3UH	75382	21	11	80EL2N13MOTIONFAIL	96182	23	31
603CY1251	75382	47	11	80EL2N13NOTASSIGNED	96182	23	31
604C2UH	75382	59	11	80EL2N13PARITYERROR	96182	23	31
604C8UH	75382	58	8	80EL2N13PRINTFAIL	96182	23	31
60524-3	00779	98	3	80EL2N13PUNCHERROR	96182	23	31
60598-1LP	00779	74	3	80EL2N13PUNCHFUSE	96182	23	31
60598-1LP	00779	76	18	80EL2N13BLACKTAPE	96182	23	31
61117-1	00779	56	7	80EL2N13TAPEOUT	96182	23	31
61118-1	00779	52	7	80EL2N13LIGHTTAPE	96182	23	31
61118-1	00779	53	9	800-14-KT26	75382	65	65
61118-1	00779	54	5	8058-1G49	91506	90	7
61380-1	00779	98	1	810002-080	12436	22	5
6193SS0832	06540	74	92	82-32-101-17	94222	27	16
62-99-220-30	24248	25	2	82-46-101-39	94222	27	14
63130	06809	93	24	822250632-7	06540	93	6
639139-467	51889	27	2	8223-A-0632	06540	65	61
640RJ8	75382	58	9	832637	12344	39	9
7SU5795-803	96906	81	8	833070	12344	41	11
7X.18	63743	70	1	833301	12344	31	52
7484	74545	46	15	833594	12344	39	1
75F1R1B103	03508	52	16	845-101-088	06809	79	11
75F1R1B103	03508	55	5	845-122-049	06809	73	76
75F1R1B103	03508	56	30	86F1061MA	03508	47	56
75F1R1B472	03508	48	1	86F1062MA	03508	47	47
75F1R2B103	03508	52	1	86F1063MA	03508	47	45
75F2R1B473	03508	49	1	86F1064MA	03508	47	21
75F2R18473	03508	50	1	86F1065MA	03508	47	13
75F3R18104	03508	48	2	86F1067MA	03508	47	35
75F3R18104	03508	49	2	86F2004MA	03508	47	40
75F3R1B104	03508	55	2	86F262MA	06001	93	36
77-M1P-8-T	02660	65	32	877682	66059	31	70
77M1P8	02660	93	5	877683	66059	31	41
77PR500	73138	50	23	8824K14	15605	22	6
77PR500	73138	55	47	890050	12344	30	152
77PR500	73138	48	22	890202	12344	46	12
77PR500	73138	49	22	893-105-009	06809	73	28
77R4XR1C	43334	45	22	903090	12344	42	4
79NCFMA2-82	72962	93	37	903450	12344	40	3
79NM02	72962	74	98	904030	12344	46	21
79NM02	72962	79	10	91122	08280	61	4
80EA1	96182	23	29	91252-126	80089	93	28
80EA1F1AL2N13LOWTAPE	96182	23	2	91252-56	80089	30	121
80EA1F1AL2N13NOTASSIGNED	96182	23	1	933-107-102	06809	74	45
80EA1F1AL2N13PRINTFAIL	96182	23	19	933-118-010	06809	72	13
80EA1F1AL2N13SLACKTAPE	96182	23	20	95605	06809	93	25
80FA1F1RL2N13MOTIONFAIL	96182	23	4	97A	94682	47	19
80EA1F1RL2N13PARITYERROR	96182	23	6	97A001X	95682	65	57

LATEST NATIONAL STOCK NUMBER ASSIGNMENTS

STOCK NUMBER	FIG. NO.	ITEM NO.	STOCK NUMBER	FIG. NO.	ITEM NO.
5340-00-003-9207	1	69	5962-00-791-0994	10	5
5340-00-003-9207	52	9	5962-00-791-0994	11	4
5340-00-003-9207	53	11	5962-00-791-0994	12	2
5340-00-003-9207	54	7	5962-00-791-0994	13	2
5340-00-003-9207	90	17	5962-00-791-0994	14	4
5910-00-007-3974	18	4	5962-00-791-0994	15	4
5962-00-007-4099	97	31	5962-00-791-0994	16	5
5355-00-018-4533	78	4	5962-00-791-0994	17	13
7040-00-019-0866	74	81	5962-00-791-1048	9	2
7040-00-019-0922	74	63	5962-00-791-1082	9	4
7040-00-019-0976	74	62	5962-00-791-1082	11	3
7040-00-019-1002	75	9	5962-00-791-1082	12	3
7040-00-019-2146	76	23	5962-00-791-1082	13	3
7040-00-019-2949	32	58	5962-00-791-1082	15	3
5360-00-022-4494	30	46	5962-00-791-1082	16	3
7040-00-036-3844	73	73	5962-00-791-1082	17	14
5310-00-043-1754	52	11	5962-00-791-1120	9	3
5905-00-051-8003	49	27	5962-00-791-1120	12	4
5305-00-054-5653	52	10	5962-00-791-1393	11	2
5305-00-054-6669	73	45	5962-00-791-1393	14	9
5305-00-057-0508	31	6	5962-00-791-1393	15	10
5305-00-057-0508	31	25	5962-00-791-1393	16	2
5305-00-057-0508	33	8	5961-00-805-7874	40	1
5305-00-057-0508	34	8	5910-00-812-2751	89	2
5305-00-057-0508	35	7	5935-00-816-8713	95	2
5305-00-057-0508	36	7	5310-00-834-8736	47	55
5961-00-060-6817	56	15	5961-00-836-6667	91	7
5365-00-064-6279	32	33			
5905-00-081-6137	54	13	5310-00-845-1894	74	7
5961-00-088-8792	49	6	5310-00-845-1894	79	9
5961-00-088-8792	55	7	5961-00-846-5808	56	10
5961-00-088-8792	56	26	5961-00-850-8921	62	17
5961-00-088-8792	97	8	5961-00-851-8293	97	11
5961-00-088-8792	98	16	7040-00-852-6354	76	14
5935-00-102-8101	1	38	5961-00-853-6454	29	22
5961-00-103-3981	90	4	5340-00-862-7670	65	15
7510-00-104-9334	71	5	5935-00-868-4188	29	5
5945-00-107-0747	55	12	5961-00-882-4566	89	13
5905-00-107-0818	48	22	5961-00-902-7969	85	8
5905-00-107-0818	49	22	5961-00-902-7969	86	8
5905-00-110-0310	62	3	5961-00-902-7969	87	9
5961-00-133-2884	50	9	5905-00-904-7081	85	15
7040-00-134-8192	74	69	5905-00-904-7081	87	17
5305-00-137-3445	79	3	5905-00-904-7083	89	16
5940-00-143-4794	94	2	5905-00-904-7083	91	21
5962-00-167-7897	9	5	5961-00-924-6981	42	1
5962-00-167-7897	10	4	5961-00-925-3749	88	7
5962-00-167-7897	11	5	5961-00-925-3749	89	14
5962-00-167-7897	12	5	5950-00-925-8958	89	11
5962-00-167-7897	13	4	5360-00-926-5421	36	10
5962-00-167-7897	14	3	5360-00-926-5425	73	75
5962-00-167-7897	15	5	7035-00-926-7708	71	7
5962-00-167-7897	17	15	5961-00-930-5325	40	6
5330-00-191-3934	30	30	5910-00-931-9890	66	4
5961-00-244-6905	55	11	3030-00-933-8564	73	1
7440-00-324-4451	74	64	7035-00-935-1338	71	6
7040-00-398-9646	71	1	7040-00-936-2323	72	23
5905-00-403-3062	90	16	5910-00-937-2052	69	18
5910-00-412-9235	4	3	5999-00-946-0947	70	19
3120-00-434-1467	74	57	5961-00-949-1440	48	7
5365-00-480-2420	74	76	5961-00-949-1440	49	8
5975-00-497-2158	98	13	5961-00-949-1440	50	6
5340-00-576-2157	30	125	5910-00-952-6432	85	3
5920-00-583-8486	57	2	5910-00-952-6432	86	3
5310-00-596-8718	47	73	5910-00-952-6432	87	3
5340-00-684-9956	57	7	5910-00-952-6432	91	3
5305-00-686-5659	30	29	5910-00-952-6432	92	3
5905-00-689-5771	50	18	5310-00-954-2353	74	27
5961-00-712-5578	54	10	5365-00-957-7776	32	9
5305-00-717-6951	32	51	5365-00-957-7776	39	3
5961-00-752-0150	40	12	5940-00-983-6044	73	21
5305-00-764-0080	74	96	5961-00-988-1911	84	2
5905-00-781-9660	53	20	5940-00-990-1658	92	12
5310-00-782-1349	93	22	5910-00-016-0116	62	27
5910-00-787-2109	55	4			

SECTION IV

NATIONAL STOCK NUMBER AND PART NUMBER INDEX

LATEST PART NUMBER ASSIGNMENTS

PART NUMBER	FSCM	FIG. NO.	ITEM NO.	PART NUMBER	FSCM	FIG. NO.	ITEM NO.
AN960C4	88044	93	22	MS35337-79	96906	52	11
CM06FS61J03	81349	85	3	MS51957-44	96906	73	45
CM06F561J03	81349	86	3	MS51963-3	96906	32	51
CM06F561J03	81349	87	3	M39003-01-2981	81349	4	3
CM06F561J03	81349	91	3	M39003-01-2991	81349	18	4
CMD6F561J03	81349	92	3	M39006-09-8717	81349	62	27
C7091K	18324	16	2	RC20GF392K	81349	62	3
C7580K	18324	16	5	RLR20C432GR	81349	90	16
C7580K	18324	17	13	RN60D1582F	81349	49	27
DE90JS19977-5	71468	74	2	RW67VR33	81349	53	20
DE90JS19977-5	71468	83	2	RW69V5R1	81349	54	13
DE90JS19977-5	71468	94	7	10079	07047	70	19
DE90JS19977-5	71468	95	2	150D564X9035A2	56289	89	2
F038125V3A	81349	57	2	2N1412	81349	29	22
JAN1N4245	81349	42	1	300371	12344	36	10
JAN1N816	80131	91	7	34D108G01SGL4	56289	66	4
JAN2N3442	81349	54	10	37T83	81349	73	21
JAN2N683	80131	56	15	56658-1	12436	71	5
MS17122-6	96906	92	12	75F1R1B103	03508	53	12
MS17821-1-9	96906	98	13				

ADDITIONAL LATEST NATIONAL STOCK NUMBER ASSIGNMENTS

STOCK NUMBER	FIG.	ITEM	STOCK NUMBER	FIG.	ITEM
7040-00-009-3471	43	13	5935-00-880-5441	74	1
5305-00-064-6655	43	4	5961-00-883-6064	88	3
7440-00-152-0041	43	10	7040-00-895-3982	43	9
5310-00-261-8278	47	50	5310-00-929-6395	43	2
7440-00-318-7623	43	12	5310-00-934-9761	43	1
7445-00-411-8654	43	11	5961-00-949-1440	8	4
5962-00-477-9455	97	33	5305-00-969-6495	43	15
5365-00-598-8635	43	26	5310-00-988-0358	93	37
5305-00-719-5064	43	8	4140-00-988-3695	60	8
5310-00-722-5948	43	10	4935-01-003-8409	43	7
5905-00-865-0361	55	52	4935-01-003-8410	43	6
4920-00-874-9758	88	26	5360-01-048-5990	43	20
4920-00-874-9758	89	33	5365-01-048-6054	43	19

ADDITIONAL LATEST PART NUMBER ASSIGNMENTS
CONTINUED ON NEXT PAGE

SECTION IV

NATIONAL STOCK NUMBER AND PART NUMBER INDEX

ADDITIONAL LATEST PART NUMBER ASSIGNMENTS

PART NUMBER	FSCM	FIG. NO.	ITEM NO.	PART NUMBER	FSCM	FIG. NO.	ITEM NO.
AC-180-026-688	91440	43	24	00-002539-001	06809	43	21
AE-188-022-1750	91440	43	20	00-002540-001	06809	43	27
CS13BF105K	81349	55	4	01-004472-001	06809	43	19
JAN1N749A	81349	88	3	01-004472-002	06809	43	22
JAN1N749A	81349	89	6	01-004472-002	06809	43	25
MS15795-805	96906	43	3	01-004474-001	06809	43	5
MS24693-C25	96906	43	15	01-004480-001	06809	43	17
MS35338-100	96906	47	50	304670	12344	43	9
MS35338-136	96906	43	2	318870	12344	43	11
MS35649-264	96906	43	1	324130	12344	43	7
MS51957-31	96906	43	4	333052	12344	43	12
MS51959-30	96906	43	8	333751	12344	43	13
00-002534-001	06809	43	16	345521	12344	43	10
00-002535-001	06809	43	18	398270	12344	43	6
00-002537-001	06809	43	28	5100-25MD	79136	43	14
00-002538-001	06809	43	23	5555-12	79136	43	26

*U.S. GOVERNMENT PRINTING OFFICE: 1981-564-016123

By Order of the Secretaries of the Army, the Navy, and the Air Force:

BERNARD W. ROGERS
General United States Army
Chief of Staff

Official:

J. C. PENNINGTON
Major General, United States Army
The Adjutant General

EARL B. FOWLER
Rear Admiral United States Navy
Commander, Naval Electronic Systems Command

Official:

LEW ALLEN, JR., General USAF
Chief of Staff

BRYCE POE II, General USAF
Commander, US Air Force Logistics Command

DISTRIBUTION:

Active Army

USAINSCOM (2)
DARCOM (1)
TRADOC (2)
OS Maj Comd (5)
USACOMZEUR (5)
USAREUR (5)
TECOM (2)
USACC (10)
USACC-PAC (2)
USACC-EUR (25)
USACC-SO(10)
USACC-A (5)
HQ. 7th Sog Comd (5)
Sig Gp (USACC) Japan (3)
Sig Gp (USACC) Tiawan (3)
USASATCOMA (2)
USACSA (4)
USASIGS (5)
USAICS (3)
7 & 8th Armies (4)
Corps (2)
Army Dep (2) except
LBAD (10)
SAAD (25)
TOAD (14)
USAERDAA (1)
USAERDAW (1)

Fort Gillem (10)
Fort Carson (5)
Ft Monmouth (HISA) (26)
Ft Richardson (CERCOM) (1)
Gen Deps (2) except
Pirmasens (10)
Sig Dep (2)
Sig Sec Gen Dep (2)
Units org under fol TOE:
(1 cy each unit)
11-75
11-85
11-95
11-98
11-137
11-302
11-347
11-367
11-368
11-500 (AA-AC)
29-134
29-136

NG: None

USAR: None

For explanation of abbreviations used, see AR 310-50.

RECOMMENDED CHANGES TO EQUIPMENT TECHNICAL PUBLICATIONS



THEN . . . JOT DOWN THE DOPE ABOUT IT ON THIS FORM. CAREFULLY TEAR IT OUT, FOLD IT AND DROP IT IN THE MAIL!

SOMETHING WRONG WITH THIS PUBLICATION?

FROM: (PRINT YOUR UNIT'S COMPLETE ADDRESS)

DATE SENT

PUBLICATION NUMBER

TM 11-5825-270-10

PUBLICATION DATE

23 Jul 81

PUBLICATION TITLE

Radio Frequency R-2176/FRN

BE EXACT . . . PIN-POINT WHERE IT IS

PAGE NO.	PARA-GRAPH	FIGURE NO.	TABLE NO.

IN THIS SPACE TELL WHAT IS WRONG AND WHAT SHOULD BE DONE ABOUT IT:

TEAR ALONG PERFORATED LINE

PRINTED NAME, GRADE OR TITLE, AND TELEPHONE NUMBER

SIGN HERE:

DA FORM 2028-2
1 JUL 79

PREVIOUS EDITIONS ARE OBSOLETE.

P.S.—IF YOUR OUTFIT WANTS TO KNOW ABOUT YOUR RECOMMENDATION MAKE A CARBON COPY OF THIS AND GIVE IT TO YOUR HEADQUARTERS.

PIN: 040625-000